

TSBF Institute

Annual Report 2003



TABLE OF CONTENTS

1. DIRECTOR’S REPORT	3
1.1. RESEARCH FOR DEVELOPMENT FRAMEWORK	3
2. RESEARCH ACHIEVEMENTS AND ACTIVITIES	11
OUTPUT 1: IMPROVED SYSTEM RESILIENCE AND PROFITABILITY THROUGH DIVERSIFICATION AND INTENSIFICATION OF AGRICULTURAL PRODUCTION	11
OUTPUT 2: IMPROVED AGROECOSYSTEM HEALTH THROUGH MANAGEMENT OF BELOW GROUND BIODIVERSITY (BGBD).....	67
OUTPUT 3 – ENHANCED PROVISION OF SOIL-BASED ECOSYSTEM SERVICES (WATER QUALITY AND QUANTITY, SOIL C, EROSION CONTROL) WITHIN FOOD SECURE LAND USE SYSTEMS.....	79
OUTPUT 4: STRATEGIES FOR SCALING UP AND OUT OF ISFM PRACTICES DEVELOPED, IMPLEMENTED AND EVALUATED.....	90
OUTPUT 5 – RESEARCH AND TRAINING CAPACITY OF STAKEHOLDERS ENHANCED.....	110
3. ANNEXES.....	117
1. PROJECT DESCRIPTION AND LOGFRAME	117
2 LIST OF STAFF	122
3. LIST OF STUDENTS	125
4. COLLABORATORS	136
5. LIST OF PUBLICATIONS	140

1. DIRECTOR'S REPORT

1.1. Research for development framework

A comprehensive review of the strategic direction of TSBF-CIAT was recently undertaken during two retreats, one in Kenya (9–12 June) and the other one in Colombia (17–20 June). The need for this review arose from the recommendations of an external programme and management review conducted in 2000, the strategic directions defined for TSBF for 2001–2005, the outcome of a meeting of a panel of experts in Bellagio, Italy, in 2002, and TSBF's merger with CIAT. There was also the need to reflect on questions regularly asked by donors and other development partners, concerning:

- ?? The impact at the farm level of TSBF-CIAT's soil fertility research
- ?? TSBF-CIAT's capacity to manage and implement large projects
- ?? How TSBF links good science with adaptive research

The purpose of the review was to determine if and how TSBF-CIAT should reposition its research strategies and goals given its merger with CIAT and the appointment of the new director, Dr Nteranya Sanginga.

The review suggested no radical change to our programme but it pointed the direction along which the institute should continue during 2003–2007. Some of the important highlights of the review are discussed in the following sections.

Integrated Soil Fertility Management

TSBF began in 1984 as a body devoted to researching the role of soil biology in maintaining soil fertility and combating environmental degradation. The knowledge generated by TSBF during the last two decades, including scientific principles, research methods, and land-use practices for sustaining tropical soil fertility through the management of biological processes and organic resources, has profoundly influenced the scientific communities working throughout the tropics.

Today, as an institute of CIAT, TSBF-CIAT is dedicated to translating scientific knowledge on soil biological processes into practical land-management strategies, and empowering farmers through participatory technology development.

TSBF-CIAT is now a leader in the development of integrated soil fertility management (ISFM; see figure 1), whereby organic resources available to farmers are complimented with judicious use of mineral inputs and improved resilient germplasm, to strengthen food security, improve rural livelihoods, strengthen local knowledge and protect soil resources.

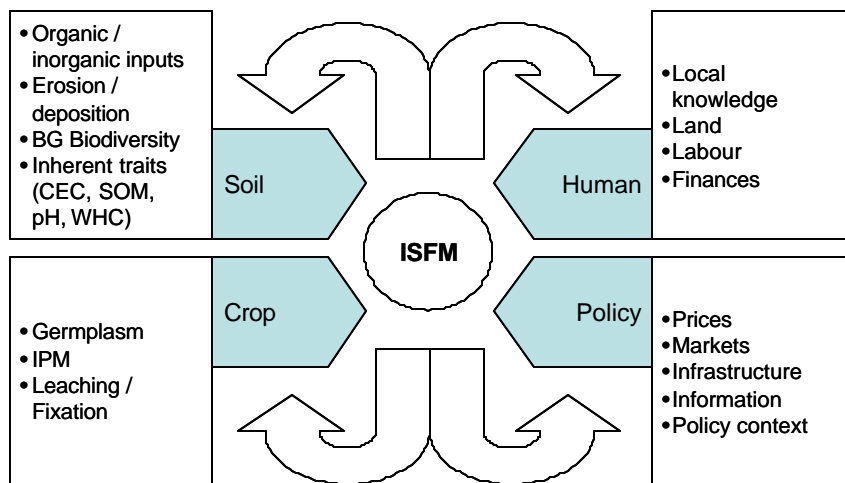

Figure 1. The processes and components of integrated soil fertility management (ISFM)

[BG: below-ground; CEC: cation exchange capacity; SOM: soil organic matter; WHC: water holding capacity; IPM: integrated pest management]

Developing research products for and in partnership with smallholder farmers in the tropics underlies TSBF-CIAT's research and development agenda for 2003–2007.

Output and farming system foci

The institute's expected outputs and farming systems' foci are shown in figure 2. The flow of process-based research comprises output 1, system resilience and profitability; output 2, belowground biodiversity; and output 3, ecosystem services. These outputs generate components and information that are integrated in the adaptive research process in output 4 to scale up successful products and principles, and output 5 to empower stakeholders, especially smallholder farmers, to undertake collective ISFM action.

World -wide Applications

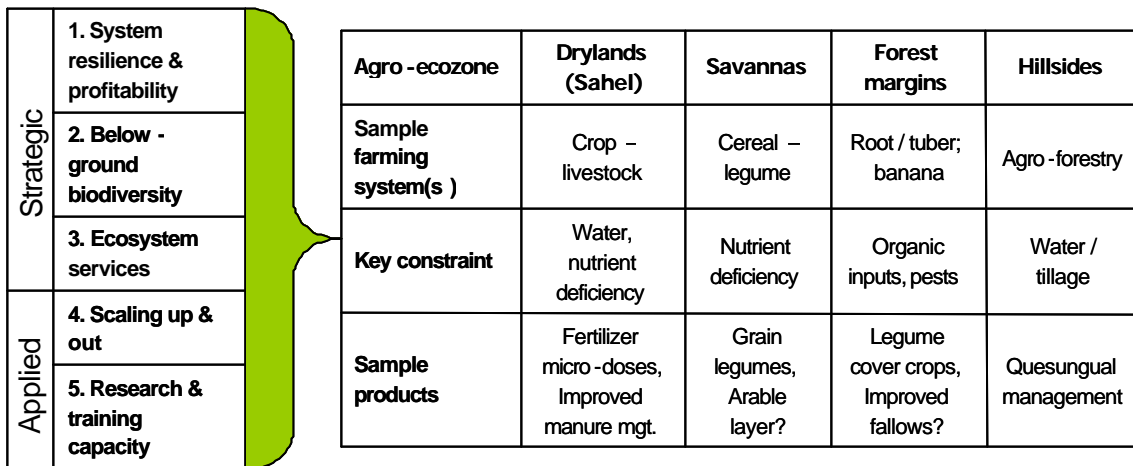

Figure 2. Integrating and applying the research outputs of TSBF-CIAT world-wide.

An interacting flow of outputs exists between different farming systems i.e., between the cereal-legume and the livestock systems, between the banana- and the cassava-based systems, and between the Quesungual and other agroforestry systems. These systems have been selected based on their importance and opportunities they offer farmers located in the major agroecological zones (hillsides, savannas and forest margins) in both Africa and Latin America.

An example of system technologies involve the introduction of new, more productive but sustainable farming systems in which new maize cultivars bred for improved N-use efficiency, *Striga*, stem borers resistance and drought tolerance are rotated or relay cropped with (i) new food/forage legume crops with low harvest indices (e.g., newly bred common beans resistant to pest, promiscuously nodulating soybean and dual-purpose cowpea) or (ii) drought tolerant cassava or banana cultivars resistant to nematodes. Such an approach will promote sustainable agriculture through the contributions of residual soil N and organic matter to subsequent crops, efficient utilization of minimal amounts of external inputs, reduction of *Striga* population and other pests and diseases as well as enhancing the contribution of livestock. Identifying market opportunities for higher value crops such as vegetables, multipurpose legumes and fruit trees is important for income generation and for increasing the sustainability and biodiversity of these farming systems.

The other system we are workin on is the Quesungual Slash and Mulch Agroforestry System (QSMAS) as an approach to restore degraded sub-humid tropical hillsides in Central America. This alternative to slash and burn agriculture strongly builds on local knowledge and has been a critical option to achieve food security by resource poor farmers in the region. The widespread adoption of the QSMAS by more than 6,000 farmer households has been driven by more than 100% increase in crop yields and cattle stocking rates and reduced costs associated with agrochemicals and labor. Contrary to other agroforestry systems tested in sub-humid tropics with long dry seasons, where crops and trees coexist under intense competition for water, farmers recognize that a remarkable feature of the QSMAS is the increased soil water holding capacity and availability. Curiously, two recent extreme events (El Niño drought in 1997 and Hurricane Mitch in 1998) were considered among best promoters of adoption because areas under QSMAS were minimally affected compared to areas under traditional slash and burn

practices. Understanding the socio-economic and biophysical processes that drive the adoption and successful performance of the QSMAS in sub-humid areas is of critical importance to be able to derive principles that can be extrapolated to similar environments elsewhere.

Fertilizer research for practical land-management strategies

TSBF-CIAT is consistently asked about its policy on promotion and use of mineral fertilizers. From our perspective, mineral fertilizers are absolutely necessary but not completely sufficient for the productive and sustainable management of tropical soils. Long-term trials show that nutrient use efficiency declines over time where mineral fertilizers are applied without organic inputs. The soil management strategy depends on getting both appropriate types of fertilizer and appropriate means of managing organic resources in the farming system, and as such on reducing the costs of both information and fertilizer. TSBF-CIAT has produced enough results supporting this strategy but will continue to research this topic, with emphasis on translating existing scientific knowledge into practical land-management strategies.

The work on mineral fertilizer is done primarily in collaboration with the International Fertilizer Development Corporation and in the nearest future through grants provided by the Rockefeller Foundation to study mineral fertilizer marketing, and policy.

Our contribution is intended at quantifying the use efficiency of mineral fertilizer (even when applied at the high rates), and designing and evaluating the effects of different management options and technologies on improved nutrient use efficiency and recycling.

Germplasm as entry point for ISFM technology adoption and land degradation recuperation

Improved adapted germplasm will be used to overcome abiotic and biotic constraints and to create resilient cropping systems. TSBF-CIAT and its partners will continue to evaluate and integrate improved, adapted, resilient and marketable germplasm to tackle soil fertility constraints to crop production with emphasis on maize, improved dual-purpose legumes, and bananas.

Breeding and biotechnology can help small farmers to sustainably increase productivity by:

1. reducing production risks via improved drought tolerance, soil acidity tolerance, pest resistance and increased efficiency of N-fixation;
2. selecting crop species, accessions and varieties through on-farm evaluation over a range of soils to identify potential soil-related constraints to production; considering abiotic constraints such as acidity, low P, N and drought.

Belowground diversity research

TSBF-CIAT will continue research on belowground biodiversity as a means of beneficially managing soil biology through the GEF-UNEP funded project on below-ground biodiversity (BGBD). The project addresses the means by which below-ground biodiversity may be adequately managed and conserved in tropical agricultural landscapes. The processes of land conversion and agricultural intensification are a significant cause of biodiversity loss, including that of BGBD, with consequent negative effects both on the environment and the sustainability of agricultural production.

The objective of the project is 'to enhance awareness, knowledge and understanding of below-ground biological diversity important to sustainable agricultural production in tropical landscapes by

the demonstration of methods for conservation and sustainable management'. The project has a particular focus on tropical forest margins and the complex community of organisms which regulates soil fertility, greenhouse gas emissions and soil carbon sequestration, and which is routinely ignored in biodiversity conservation and assessment projects. The project will explore the hypothesis that, 'by appropriate management of above- and below-ground biota, optimal conservation of biodiversity for national and global benefits can be achieved in mosaics of land-uses at differing intensities of management and furthermore result in simultaneous gains in sustainable agricultural production'.

In order to achieve this goal the project will produce five primary outcomes:

1. Internationally accepted standard methods for characterization and evaluation of BGBD, including a set of indicators for BGBD loss.
2. (a) Inventory and evaluation of BGBD in benchmark sites representing a range of globally significant ecosystems and land-uses.
(b) A global information exchange network for BGBD.
3. Sustainable and replicable management practices for BGBD conservation identified and implemented in pilot demonstration sites in representative tropical forest landscapes in seven countries.
4. Recommendations of alternative land use practices, and an advisory support system, for policies that will enhance the conservation of BGBD.
5. Improved capacity of all relevant institutions and stakeholders to implement conservation and management of BGBD in a sustainable and efficient manner.

Integrated management of soil pests, diseases and nematodes will be of particular importance in ISFM practices. Belowground diversity research also complements the work on breeding of cereals and legumes tolerant to soil stresses, particularly drought and low soil fertility.

ISFM agenda to include farm-level social dynamics

The key contribution of social science to ISFM often appears limited to identifying and understanding the social factors that limit 'adoption' or 'appropriateness' of given technologies. Other socio-cultural phenomena such as 'policy' might be acknowledged as important to the fate of different innovations, but most teams, even multidisciplinary ones, lack the capacity to develop relevant policy-related questions, experiments or interventions.

The process of developing the TSBF-CIAT research agenda, which looks beyond the soil to the people, is described in the paper 'Finding common ground for social and natural science in an interdisciplinary research organization, the TSBF experience' (Ramisch, Misiko and Carter, 2002). The social science research agenda has moved from descriptive characterization of farming systems to more strategic study of social differentiation, power and networks as they relate to soil fertility management innovation. Interest in dissemination has broadened into investigation of social dynamics, farmer knowledge and farm-level decision making. The core activities relating to social science will retain an anthropological focus, including research on indigenous soil ecological knowledge, farmer decision making, understanding innovation processes and the role of social differentiation in ISFM practices.

Moving from plot to landscape scale

Strategic and component research to date has been conducted largely at the plot or field scale, where interactions among various agricultural enterprises are seldom considered. Although TSBF-

CIAT's strength remains at the plot level, the diversity of forces impinging on the plot naturally draws attention towards a hierarchical systems-based approach.

The next generation of work will be at wider scales, particularly the farm and landscape scales. The rationale for working at the farm scale is the need to improve nutrient use efficiency through better allocation of the limited organic and inorganic resources among different enterprises, taking into consideration inherent soil variability within the farming system. Inadequacies in supplies of both organic and inorganic nutrients have created strong fertility gradients even within the smallest farms. Smallholder farmers typically remove harvest products and crop residues from their food producing 'outfields' and devote their scarce soil inputs to their smaller market 'infields', resulting in large differences in soil productivity over time between these two field types. Understanding how to manage the limited nutrient supplies across such fertility gradients is a key component in raising productivity in staple crops' fields.

Environmental services, particularly hydrological response and soil erosion control, can be managed effectively only at larger landscape scales. Research at the watershed scale is just beginning in the region, and given that projections indicate that eastern and southern Africa and Central America will be critically short of water in the coming decades, extending TSBF-CIAT's research agenda into those regions is warranted. The new proposals approved by the Water and Food Challenge Program for the Volta in West Africa basins and that on the Quesungual systems in Central America offer the opportunity to address constraints related to water and its interaction with soil fertility and other environmental challenges.

Strong linkages are envisaged between TSBF-CIAT and CIAT PE-3 project on Communities and Watersheds, PE-4 on Land use in Latin America and the Lake Victoria ICRAF's lead project in East Africa. TSBF-CIAT is also playing an important role in the development and implementation of the CIAT's strategic document on land degradation.

Decision tools as important components in research

Decision tools for improved soil, nutrient and water management are being developed and disseminated for testing by researchers. Links are sort with other research institutions such as the Wageningen University, using the framework of NUANCES (Nutrient Use in Animal and Cropping systems Efficiency and Scales). Other more established models and Decision Support Systems that are being used in TSBF-CIAT research include NUTMON, QUEFT, APSIM, NuMaSS, CENTURY and DSSAT.

Crosscutting research themes between Latin America and Africa

Short-term integration activities included: a) cross-method analysis of organic resource characterization, b) application of TSBF approaches at landscape level, c) dual-purpose live barriers, d) CIAT germplasm in Africa/integrate with IPSFM, and e) arable layer concept dissemination through African Tillage Network and f) exchange of students between the two continents. These activities are at different stages of progress and it is clear that we need earmarked funds set aside to support such initiatives to completion.

African and Central American teams share experience

For the first time since the TSBF-CIAT merger in December 2001, this year, our Latin American team shared experiences with some of their African counterparts at our field sites in Central America. These visitors included the TSBF-CIAT director, Nteranya Sanginga, together with Bernard Vanlauwe and Joshua Ramisch. This visit was an important step in our efforts to develop a common

research agenda, and provided an appropriate opportunity for discussion on key aspects of our new strategic approach. It also included participation in the annual Manejo Integral de Suelos (MIS) meeting. This meeting gathers annually our key Central American collaborators from Honduras, Nicaragua and Guatemala.

The team visited the hillside areas in the Lempira department, Honduras, where we are conducting collaborative studies with the Food and Agriculture Organization of the United Nations (FAO) on the indigenous Quesungual slash-and-mulch system. This system provides an alternative to slash-and-burn land management, and it incorporates annual crops (maize, sorghum and beans) and pastures in an arrangement that manages natural plant regeneration and provides permanent soil cover. Besides its substantial contribution to food security, this indigenous system has shown considerable resilience to extreme water deficits and to excess water during natural catastrophes. Farmers practising Quesungual farming reported lower soil, water and crop losses from the El Niño drought event in 1997 and Hurricane Mitch in 1998. This slash and mulch system appears to not only conserve water but also improve its quality for downstream users. It has great potential for adoption by resource-poor farmers in similar hillside areas of Latin America, Africa and Asia.

Network and regional linkages

TSBF-CIAT research is implemented mainly through collaboration with national scientists working in networks. The African Network for Soil Biology and Fertility (AfNet) now has about 200 members from universities and national agricultural research systems (NARS) in over 15 countries. The AfNet coordinator is based at TSBF-CIAT in Nairobi and has a major responsibility to work with network members to raise funds for research and capacity building. A smaller network in India, the South Asia Regional Network (SARNet), is coordinated from the Jawaharlal Nehru University in Delhi.

The MIS (Manejo Integrado de Suelos) consortium operating in Central America is very active in Nicaragua and Honduras. The other networks are the GEF/UNEP Below-Ground Biodiversity Project (BGBD) including Uganda, Kenya, Cote d'Ivoire, India, Indonesia, Brazil, and Mexico. TSBF-CIAT staffs also participate in a number of systemwide and coregional programmes such as the Soil, Water and Nutrient Management (SWNM) Systemwide Program, Alternatives to Slash-and-Burn Programme (ASB), the African Highlands Initiative (AHI) And the Desert Margin Programme (DMP).

AfNet structure and focus to match network growth and regional needs

The steady growth of AfNet has made it necessary to form strategic country and regional multidisciplinary teams. These teams will develop models linking research on ISFM, agricultural production and markets in the three African regions covered by the Association for Strengthening Agricultural Research and Training in East and Central Africa (ASARECA), le Conseil Ouest et Centre Africain pour la Recherche et le Développement Agricoles (CORAF) and the Southern Africa Centre for Agricultural Research and Training (SACCAR). These teams will also prepare the research and development agenda for the sub-Saharan challenge programme. AfNet will start with potential existing teams and foster the formation of new teams in regions where they do not exist. One way to do this will be to structure the invitations to the next AfNet meeting around potential teams, building on nuclei of one or two key AfNet members.

Human capital development will continue to be an integral part of AfNet, in which the research agenda is achieved through MSc and PhD research conducted at African public universities and elsewhere, followed by research support for recent graduates on return to their home institutions. An innovative initiative between TSBF-CIAT and the International Foundation for Science (IFS) has

helped young and bright Msc and PhD graduates throughout sub-Saharan Africa to develop project proposals for IFS funding along TSBF-CIAT's major research and development themes. AfNet is involved in ensuring that such scientists are not alienated in isolated research settings due to lack of peer support, resources or recognition. This scheme also increases the research and development capacity of national systems, rather than redundant research.

Short-term specialized training on subjects such as NUTMON, resource flow maps and participatory approaches in ISFM is organized on demand by members through AfNet. TSBF-CIAT is assisting in soil science curriculum reform as part of a broader curriculum reform process under way in universities in eastern and southern Africa through the Rockefeller Foundation's Forum on Agricultural Resource Husbandry, which is designed to strengthen MSc training.

The relevance and importance of social science contributions within AfNet are acknowledged but so far social science is not backed by resources or strong champions within the network. As a result TSBF-CIAT is still perceived amongst partners as essentially a biology-based organization with minimal social science input. To counter this misconception, active recruitment of social scientists has begun through networking and proposal development.

2. RESEARCH ACHIEVEMENTS AND ACTIVITIES

Output 1: Improved system resilience and profitability through diversification and intensification of agricultural production

Output Rationale

Soil fertility degradation has been described as one of the major constraints to food security in developing countries, particularly in Africa and Latin America. Despite proposals for a diversity of solutions and the investment of time and resources by a wide range of institutions it continues to prove a substantially intransigent problem. The rural poor are often trapped in a vicious poverty cycle between land degradation, fuelled by the lack of relevant knowledge or appropriate technologies to generate adequate income and opportunities to overcome land degradation.

Intensification and diversification of agricultural production on smallholdings is required to meet the food and income needs of the poor, and this cannot occur without investment in soil fertility. Investing in soil fertility management is necessary to help households mitigate many of the characteristics of poverty, for example by improving the quantity and quality of food, income, and resilience of soil productive capacity.

Farmers in the tropics, particularly in Africa rely mainly on organic inputs to maintain or improve soil fertility, with small or no additions of inorganic fertilizers. Within the ISFM framework, it is now recognized that both organic and mineral inputs are necessary to enhance crop yields without deteriorating the soil resource base. This recognition has a practical dimension because either of the two inputs are hardly ever available in sufficient quantities to the small scale farmer, but it also has an important resource management dimension as there is potential for added benefits created by positive interactions between both inputs when applied in combination. Such interactions can lead to improved use efficiency of the nutrients applied in organic or mineral form or both. Assessing the combination of the two in terms of resource quality, nutrient input, C, N and P dynamics and water use efficiency help to identify technology options for increasing farm productivity and system resilience.

In many respects these problems are not due to lack of a technical solution but is more linked to access to information and inputs for improved decision making to solve these problems through profitable agriculture. Access to improved multiple stress adapted crop varieties and multi-purpose legume species, improved soil and water conservation practices and improved targeting to different categories of farmers, are a few examples.

Making research activities and results available in relevant forms to smallholder farmers through extension providers is crucial to address production constraints. A range of activities from participatory situational analysis, identification and evaluation of soil fertility management technologies that meet the needs of farmers, adaptive research and capacity building of farmers, extension providers and research stakeholders are used to develop and expand these research to extension linkages.

Milestones

1. Driving forces behind soil degradation and opportunities for restoring degraded soils identified.
2. Benefits of multiple stress adapted crop and forage germplasm on productivity, profitability and soil fertility documented
3. Soil-plant management strategies to improve nutrient and water use efficiency developed
4. Trade-offs between productivity (diversification, intensification) and soil fertility improvement quantified

Activity 1.1. Improved understanding of the driving forces of land degradation and the biophysical and socio-economic constraints to effective ISFM.

Published work

Combating Soil Fertility Degradation in Africa: Problems, Progress and Partnerships

N. Sanginga

Prepared on behalf of many partners by for the Sub-Saharan Africa Challenge Programme

Tropical Soil Biology and Fertility Institute of International Center for Tropical Agriculture

Sustainable resource management is the critical agricultural research and development challenge confronting sub-Saharan Africa. As part of this, tackling soil fertility issues requires a long-term perspective and holistic approach of the kind embodied in the concept of Integrated Soil Fertility Management (ISFM) that is now driving the work of the CGIAR and its partners. Integrated soil fertility management is a core component of the Sub-Saharan Africa Challenge Programme, as expressed in the general hypothesis “*that conservation and efficiency of use of soil and other natural resources will be optimized under conditions of market- and/or policy- and institution-driven productivity.*” The ISFM concept is now also generally accepted as the appropriate paradigm for tropical soil fertility management research and development. The development of ISFM is the result of a series of paradigm shifts generated through experience in the field and changes in the overall socioeconomic and political environment that the various stakeholders, including farmers and researchers, are facing.

This position paper examines:

1. the extent and intensity of soil degradation in Africa, which necessitated a paradigm shift related to soil fertility;
2. past achievements and progress being made in Integrated Soil Fertility Management;
3. the challenges of removing constraints to adoption and dissemination of the ISFM technologies;
4. prioritized hypotheses to be tested in the SSA CP. It suggests important research issues;
5. developing partnerships for collective actions for ISFM in sub-Saharan Africa.

Increasing the relevance of scientific information in hillside environments through understanding of local soil management in a small watershed of the Colombian Andes

Thomas Oberthür¹, Edmundo Barrios², Simon Cook¹, Herman Usma¹, German Escobar¹

*¹Land Use Project, ²Tropical Soil Biology and Fertility Institute of CIAT
Centro Internacional de Agricultura Tropical (CIAT), A.A. 6713, Cali, Colombia
Soil Use and Management (in press)*

This paper explores the question of how scientific information can improve local agronomic management using concepts of uncertainty classification and uncertainty management (Cohen 1985; Rowe 1994). Information and data on local management of soil fertility based on a local classification system of soil quality were collected from a small watershed in Cauca (Colombia). The analyses show that farmers hold local knowledge about soils at two levels: the first level is based on empirical observations and refers to local knowledge about soils and landscape. It is shown that the classes identified in the local soil quality classification are consistent with results obtained using measured soil parameters. At a second level, farmers have some awareness of ecological processes and the appropriate use of relationships between key soil characteristics and management options. It is argued that local knowledge is not sufficient to cope with uncertainty introduced by a rapidly changing agriculture, including, for example, increasing land pressure, unpredictable market forces and climate change. We have suggested how scientific knowledge can contribute to the solution, based on an analysis that relates Cohen's (1985) and Rowe's (1994) uncertainty concepts to local knowledge.

Finding common ground for social and natural science in an interdisciplinary research organisation – the TSBF experience

J.J. Ramisch (TSBF-CIAT), M.T. Misiko (TSBF-CIAT), S.E. Carter (IDRC, Canada)

Conference paper from "Social Research in the CGIAR - Looking to the Future, Learning from the Past", 11-14 September 2002, CIAT, Cali, Colombia (available from http://www.ciat.cgiar.org/src/pdf/tsbf_jramisch.pdf)

Continuing dialogue between the natural and social sciences means that the conception of "development" and of integrated natural resource management (INRM) in particular, continues a healthy evolution from largely discipline-based approaches to more integrative, holistic ones. Reflecting a microcosm of this evolution, the Tropical Soil Biology and Fertility (TSBF) Institute of CIAT is today dedicated to integrated soil fertility management and the empowerment of farmers through participatory technology development. Yet its origin in 1984 was as a body devoted to researching the role of soil biology in maintaining soil fertility, to combat declining per capita food production and environmental degradation.

This paper examines the changing theoretical and methodological approaches of integrating social science into TSBF's research activities over the past decade, and identifies strategic lessons relevant to INRM research. The interdisciplinary "experiment" of TSBF has steadily taken shape as a shared language of understanding integrated soil fertility management. While individual disciplines still retain preferred modes of conducting fieldwork (i.e.: participant observation and community-based learning for "social" research, replicated trial plots for the "biological" research) a more "balanced" integration of these modes is evolving around activities of mutual interest and importance, such as those relating to decision support for farmers using organic resources. Since TSBF is working constantly through partnerships with national research and extension services, it has an important role in stimulating the growth of common bodies of knowledge and practice at the interface between research, extension, and farming. To do so requires strong champions for interdisciplinary, collaborative learning from both natural and social science backgrounds, the commitment of time and resources, and patience.

Characterization of the phenomenon of soil crusting and sealing in the Andean Hillside of Colombia: Physical and Chemical constraints

C. Thierfelder¹, E. Amézquita², R.J. Thomas³ and K. Stahr¹

¹ University of Hohenheim, Germany ² Centro Internacional de Agricultura Tropical (CIAT), Cali, Colombia³ ICARDA, Aleppo, Syria

Paper presented to the 12th ISCO Conference, Beijing, China, May 26-31, 2002.

Soil degradation is increasing around the globe, bringing challenges that demand an investigation of influencing factors. This study investigates the new degradation phenomenon of soil crusting and sealing on volcanic Inceptisols in Andean hillsides. Crusting and sealing are commonly accepted soil deterioration factors that create unstable surface conditions and soil erosion. On an Inceptisol in Santander de Quilichao in Colombia, field trials were conducted on existing erosion run-off plots using Cassava as the main crop. During the investigation, field samplings and analyses were taken of: penetration, shear strength, infiltration and cassava yield. Results from penetration and shear strength measurements clearly showed chicken manure's significant influence on soil structure. Chicken manure generally led to structural constraints. In addition, chicken manure plots displayed a reduction of infiltration. This strengthens the hypothesis that inappropriate fertilizer management is one of the key factors of structural deterioration on Inceptisols in the Andean environment. Dispersion of clays, generally cited as the main reason for soil sealing, is influenced by the impact of chicken manure. Further research will need to focus on the impact of fertilizers on the soil surface in order to design sustainable land-use systems for Andean hillside farming.

Completed work

The role of indigenous knowledge in the management of soil fertility among smallholder farmers of Emuhaya division, Vihiga district."

N. Otwoma¹ and J. Ramisch²

University of Nairobi¹ and TSBF –CIAT²

There is a growing appreciation and recognition of the importance of local or indigenous knowledge in the sustainable use of natural resources. But the lack of information stands in the way of good understanding of these methods. By taking time and effort to document the systems, they become accessible to change agents and client groups (Brokensha et al. 1999). This study will add to the search for information on soil fertility management being pursued by many researchers and planners in Emuhaya division, Vihiga district in western Kenya. The objective of the study is to describe indigenous knowledge of soils and how it relates to the management of soil fertility in the study area.

The field research phase of this study covered the long rains growing season of 2002, allowing the student to follow the on-farm activities and decision-making processes of key informants responding to various indicators of crop performance and soil fertility change. As such, it was expected to provide a useful window on an important aspect of local ecological knowledge and the extent to which it can (or does) inform local practice.

Many of the older key informants, for example, have stressed that much of the knowledge they have acquired about changing agricultural conditions is no longer particularly relevant to their livelihoods for the simple reason that their land base is now so constrained that there are fewer opportunities to match crops to given micro-sites on farm. The adapted knowledge of younger farmers, however, indicates that local soil variability can still be profitably exploited with different management strategies, at least by some classes of motivated individuals.

Increasing understanding of local ecological knowledge and strengthening interactions with formal science strengthened.

J.J. Ramisch and M. Misiko

TSBF-CIAT

This project is testing a community-based interactive learning approach, which aims to improve and sustain agricultural productivity by facilitating a common understanding between scientists, farmers and other stakeholders about how agro-ecosystems operate and how best to manage them.

The major goal of the project is to develop innovative and interactive learning tools to facilitate the exchange of knowledge and skills between farmers, scientists and other agricultural knowledge brokers. The specific focus of the project is to broaden farmers' soil fertility management strategies by incorporating scientific insights of soil biology and fertility into their repertoire of folk knowledge and practical skills.

The major activities of the first year were largely exploratory in nature, covering three main areas: 1) community studies and learning activities (this Activity section), and 2) development of methodologies for the research and for farmers to share information with each other and with researchers, and 3) monitoring and documentation

The four study sites all have some previous exposure to either TSBF or local NGO's that had worked on soil fertility management. They cover a range of agro-ecological conditions and ethnicities, and thereby present an interesting and representative diversity of communities in Western Kenya (Table 1).

Table 1. Overview of study sites

Site name	District	Ethnicity	Pop. Density (people / km ²)	Annual Precip. (mm)
Ebusiloli	Vihiga	Luyia	1100	1800-2000
Bukhalalire	Busia		384	1270-1790
Muyafwa	Busia		365	1270-1790
Aludeka	Teso	Teso	436	760-1015

(Source: Republic of Kenya, 1997; Muruli *et al.*, 1999)

The project began with introductory, community discussions, which led into exploratory group work to assess the types and extent of knowledge and assumptions held locally about soil fertility and soil ecological processes. Once this baseline study of 'folk ecological' knowledge was completed, there were various follow-up activities concentrating on key informants and specialist groups.

Community and key informant interviews and seminars

The introduction of the project centred on community interviews held in the four sites. These events, facilitated by a multi-disciplinary team had as their objectives:

- ?? Determining the local "vocabulary" used for discussing soil fertility
- ?? Identifying concepts locally related to soil fertility knowledge (classification, process, relationships)
- ?? Identifying the elements of locally understood "common sense" related to soil fertility
- ?? Identifying the individuals or groups who possess specialised knowledge of soil fertility and its management
- ?? Identifying the assumptions or "rules" of local soil fertility knowledge.

Following the initial meetings, farmers and researchers alike were eager that findings be returned to initial groups for discussion and validation. The collective findings of the community interviews were synthesised and presented back to the communities in open seminar events, which led to follow up activities on locally important themes. In particular, transect walks and other ground-truthing activities helped both broaden the involvement of community members beyond the participants of the initial meetings and to build rapport with potential key informants with specialist knowledge.

Key findings from the baseline study activities include:

- ?? Local soil types were readily identifiable. Local descriptions distinguished more soil types than were recognised as distinct soils by scientists. Soil maps are based on ‘expert opinion’ but do not reflect the high familiarity and local knowledge of farmers in daily contact with their land. Individual farmers also adapt common local names to the soils found on their own land.
- ?? Soil names reflected features of the surface layer: colour, texture, depth, fertility, erosion, first user or settler (i.e. history). Soil was understood holistically, as “mother”, “ourselves”, “life”, or “wealth”, and not just as a physical surface on which life is found. The soil was more commonly acknowledged as the source of life and wealth rather than alive or a type of wealth in its own right.
- ?? Farmers identified a diversity of directly observable, constituent parts of soil (living and non-living), including minerals, sand, silt, decaying things, worms, insects, moisture, and temperature. The presence of invisible or microscopic aspects of the soil was observed indirectly, through the growth of specific wild plants, or through crop performance.
- ?? No single local terminology exists to describe soils’ fertility status, and there was no significant gender difference in the use vocabulary or concepts. A linguistic difference was that the Teso word “*aboseteit*” referred to soil fertility and things that enhance it, while Luyia used a more general word “*obunulu*” to denote both a fertile soil and rich, fatty meat.
- ?? Multiple analogies were used when describing soil fertility, including paired opposites like “healthy / sick or hungry”, “strong / weak or tired”, “young / old”, “moist / dry”. The aspects considered important in describing fertility were texture (light, loose soils were preferred to heavier ones, which would stick on implements), colour (darker soils were considered more fertile), health or energy (as seen in crop performance, “weak”, “old”, or “tired” soils need to rest or to be fed).
- ?? Many locally known plants indicate high or low soil fertility. These indicator species, however, are not universal and their interpretation may vary. The presence of certain uncommon species may be enough to imply “high” fertility, while the relative performance of widespread species is often compared to give an indication of fertility. Generally, indicator species appear to reflect “inherent” soil properties more than trends of improvement or decline. Knowledge of plant indicators is both widely accepted and highly debated, and will be investigated further. In particular, the distribution and use of this knowledge is being more intensively studied by the Master’s student Nelson Otwoma (see “Training” below).
- ?? Respondents assumed that without inputs soils become “poor” or “worthless”. It was also widely believed that using inorganic fertilisers encourages crops to overexploit the soil’s energy and can quickly “exhaust” or “bleach” the soil. Because organic inputs have longer residual effects than inorganic ones, respondents felt that both must be used in combination, or one will disrupt a desired balance of elements in the soil.
- ?? Applying “farmyard manure” and constructing terraces were the most common soil management interventions. There was extreme individual variation between farmers in terms of what materials were included in “manure” and the manner in which they were

managed while decomposing or applied to cropland. Manure management will be a major topic for further investigation. Only farmers in Aludeka did not commonly use manure, since land is relatively abundant and trypanosomiasis limits cattle keeping.

Major changes in managing soil fertility over the last fifty years include the introduction of inorganic fertiliser, construction of terraces, systematic use of livestock manure, fallow trees and compost. Traditional farming encompassed fallowing, shifting cultivation and slash-and-burn as major practices. Practices that were introduced by the government and had been or were being abandoned include crop rotation on an annual basis, since land is too limiting. The follow-up activities with key informants have particularly emphasised participant observation of management practices, which are notoriously difficult to discuss in the abstract and are more meaningfully observed on the ground.

Issues relating to dissemination and learning

Traditionally, information was disseminated communally and government did not have a role in provision of services like agricultural extension. Farmers learned mainly through observation, apprenticeship and experience, resources were abundant and knowledge on the environment was extensive. Today, farmers have more knowledge on intensive agriculture but use of this knowledge is constrained by limited access to key resources, including land, biomass and livestock. Many farmers reported that reduced landholdings and the difficulty of acquiring new land limit their ability to fully exploit their traditional knowledge of soils and their management. As a result of land scarcity, there was little correspondence between soil type and crops grown, even when farmers stated that a given soil was not well suited to the crop being grown. Resource constraints will almost certainly limit the relevance and amount of traditional knowledge being passed on to later generations.

Usually, information about meetings and other research events is given out to relatively few farmers. This information later reaches their friends and also neighbours and relatives. In addition, most of such events are held in the open where most passers-by see. Nevertheless, some farmers did not feel encouraged to attend these events. As an example, a woman who lives adjacent to a TSBF research plot in Emuhaya said: "I would like to attend research events, but I have no one to 'follow' (i.e. orientate her to them)". She was aware that research on soil fertility had been continuing for long in her village. She also knew it would be beneficial but had never regarded herself to be part of the process.

Specifically relating to dissemination of knowledge on soil fertility, there was a common feeling amongst participants in the four sites was that there was inadequate awareness creation on soil fertility research. Many farmers did not understand how they would participate or even directly gain. It is as a result of this that many farmers still expect money or other handouts from researchers. Farmers suggested some steps that could be useful in enhancing the spread of knowledge on soil fertility:

- ?? Experimental and demonstration plots should be soil-based; located in different soil types found in the study areas, which would assist farmers to relate the practices to their situation easily. Participants observed that some trial plots may have performed better than others due to differences in soils and that some preferred practises would be inapplicable in certain soils. At present, TSBF hires trial plots depending on their availability, adequacy of size and shape of trial plot, willingness of farmers to rent their plots out and to co-operate, security, accessibility, absence of such barriers as rocks and termite mounds, representativeness of agro-ecological zones.
- ?? Plots should bear well-labelled posters showing procedures on experiments and stating that it is pure "trial" and not something automatically beneficial or "interesting" to farmers. One farmer suggested that trial plots that are managed by the researcher

should be hidden from busy roads so that they are not seen by passers-by especially when they perform poorly (as was the case with some plots in 2000).

- ?? Technologies should be better adapted to farmer conditions. Participants in focus group discussions suggested that green manure species that mature within a shorter period and which can be inter-planted with crops and/or eaten would be preferred. Such technologies should be developed so that they can be broadcast in the farm, without necessarily having to be planted carefully in lines or rows. The main concern was that new technologies should not require rigorous skill and experience.
- ?? Group-based approaches, including collectively identified and run plots can be effective venues and tools for passing new technologies to farmers. In Emuhaya, several 'Farmer Field Schools' have emerged spontaneously to broaden community participation beyond the original, rather exclusive 'Adaptive Research Farmer Groups'. Local level meetings where farmers could exchange ideas have been tried in the past in other sites, but have not been sustained. It is necessary to involve many people in activities of dissemination. Awareness can be done through field days, demonstrations, visits or exposure tours to other areas.
- ?? It is widely felt that individualistic behaviour and the absence of 'traditional' practices that once united communities (beer brewing, labour sharing, etc.) undermine collective endeavours today. It is certainly true that few activities promote positive competition amongst farmers. Household differences and clan rivalries are also major sources of division, although most key informants felt that they could be overcome with good leadership.
- ?? Low interest in research work was partly attributed to poor leadership. Researchers, like local leaders were said to "stand before farmers and address them". The two were therefore similar. Just as local leaders never delivered on their promises, research was initially seen to be unproductive. For instance, a bean variety that is suitable for N Eastern Kenya was planted on one of the key informant's plot in Emuhaya. As with the poorly performing trial plots in 2000, this inadvertently created the impression that "if a specialist's work failed, what is the point in learning how to copy it?"
- ?? Farmers have 'tools' of measuring researchers. Those with meaningful intentions and hardworking are known and easily draw farmers' attention. Farmers should be consulted when deciding on ways of teaching.
- ?? Farmer research groups have limited participation of non-members through charging of subscriptions. Most farmers perceive subscription as extortion and expressed their objection that "information from research bodies should not be passed through such groups".

On-going work

Characterization of selected Bright Spots of land and water rehabilitation in Latin America: identifying drivers that facilitate their development

M. Ayarza and N. Johnson

Centro Internacional de Agricultura Tropical (CIAT) in collaboration with the International Water Management Institute (IWMI) with the following partners: University of Essex, International Crops Research Institute for the Semi-Arid Tropics (ICRISAT) Plant Research International, Wageningen, The Netherlands, University of Tamil Nadu, India, and IWMI.

A 'Bright' spot is defined as a community or group of individuals that achieves higher food and environmental security, through improvements in (among others) land and water management. 'Bright' spots are potentially sustainable, and levels of natural resource capital are above ecological

and economic thresholds when compared to unimproved situations. The purpose of this work is to understand the key drivers (i.e. factors) that enable the development of 'Bright' spots, so as to develop strategies for their spread and replication.

Several examples of Bright Spots from Africa, Asia and Latin America were presented during a planning meeting held in Bangkok last February. Based on the discussions participants selected ten key drivers for further testing in other cases using a questionnaire developed for this purpose. Workplans were developed by participants to undertake collection of information and to carry out in-depth analysis of the drivers in few selected case studies. CIAT will collect information from Latin America and in Central America and will conduct in-depth studies in three cases: the Quesungual Slash and Mulch Agroforestry System (QSMAS) in Honduras; collective action for NRM in Versalles, Colombia and the No-till system in the northern region of Paraná, Brazil.

Some preliminary results of the information collected from three sites in Honduras: QSMAS in the Lempira region, the communal forestry system in Yuscarán and the management of broadleaf forest in Atlántida are shown. All the three cases are agroforestry systems located in different environmental and socio-economic settings.

The information collected about importance of drivers for the development and continuance of the bright spot is summarized in Table 2. It indicates that technology and social capital are the most important drivers for the initial development of improved agroforestry systems while its continuance appear to be more influenced by markets, policies, innovation and social capital.

Table 2: Ranking of importance from 1 to 5 about importance of drivers for development and continuance of bright spots in three cases from Central America.

SYSTEMS	QSMAS		PDBL		AFOCO		Total	
	Dev ¹	Cont ²	Dev	Cont	Dev	Cont	Dev	Cont
<i>Drivers</i>								
1. Quick and tangible benefits	5	3	3	3	4	3	12	9
2. Low risk of failure	4	3	4	4	4	3	12	10
3. Market opportunities	3	5	5	5	4	5	12	15
4. Aspiration for change	3	5	2	4	3	4	8	13
5. Innovation and technology	5	5	5	5	4	3	14	13
6. Leadership	5	5	5	5	3	3	13	13
7. Social capital	5	5	3	4	5	5	13	14
8. Participatory approach	4	4	4	5	5	5	13	14
9. Property rights	5	3	2	5	3	4	10	12
10. Supportive policies	3	5	5	5	4	5	12	15

¹: Dev: development of the bright spot

²: Cont: continuance of the bright spots

Adequate presence of financial systems and improved post-harvesting infrastructure were mentioned as factors equally important for both the development and continuance of the bright spots. Illegal logging and extensive cattle ranching were mentioned as main factors triggering the sustainability of the systems.

IWMI will compile and analyze information collected by participating institutions. This will culminate in an IWMI research report at the end of 2003. It is anticipated that proposals for further research in this area would be submitted to CP-SSA and GEF-desertification programs.

Construction of farm typologies in Western Kenya

P Titttonnel, B Vanlauwe, J Ramisch

The objective of the current activity was to develop farmer typologies that would apply across a range of sites and differentiate maximally between various resource allocation classes.

The selected working sites were chosen as groups of villages within the following divisions: Emuhaya in Vihiga district, Shinyalu in Kakamega district and Aludeka in Teso district. Clear gradients in altitude, rainfall, topography and soil types as well as differences in population pressure, access to markets and land use occurred between those sites.

A combination of the wealth' approach with a 'production orientation' approach was adopted. Therefore, farms were also classified according to their objective functions (e.g. self-subsistence, market oriented) (Table 1) and the main types of constraints (i.e. land, labour or cash limitations) that were identified.

Table 3: System components defined for the farm typology and their description

System component	Acronym	Description	Example
Food crops consumed by household	CSN	Crops grown on the farm to cover the food demands of the household	Maize, beans, sweet potato, local vegetables
Food crops sold on the market	MKT	Food crops grown in excess of the household food demands that are commercialised, requiring low inputs and/or low investments	Maize, beans, cabbage, groundnuts
Cash crops	CSH	Crops exclusively or predominantly grown for commercialisation that in most cases are not consumed by the household, requiring inputs and relatively high investments	Tea, coffee, sugarcane, cotton, certain vegetables
Livestock	LVSTK	Animal production activities demanding land and labour (sometimes inputs), generating cash or acting as investments	Dairy cows, goats, sheep, pigs
Woodlot	WOOD	On farm source of fuel and/or construction wood, sometimes sold on the market	Eucalyptus and Grevillea plantations
Other enterprises	OE	Other economic activities demanding labour (sometimes also land) and generating cash	Oxen services, honey bees
External food source	FOOD	Food items consumed by the household that are purchased on the market.	Maize, beans
External income source	OFF-FARM	Salary, pension, earnings from casual employment, submissions, rents and gifts flowing into the household	
Household	HOME	Family members living (and eating) on the farm, and members living outside and receiving submissions	

At each site, representative farm system models were identified that showed relevant differences according to (i) the type of system components (production activities, consumption units, income source, etc.), (ii) their relative size/importance, and (iii) the type and magnitude of the interactions between them and with external components in terms of labour, cash and nutrients.

Impact of typology and organic and mineral input use

Resource flow maps were drawn for one case study farm per farm typology, totalling 15 farms, to visualise and identify soil fertility management practices and to analyse farmers' management strategies. Fields within a farm were classified in 'home garden', 'close', 'mid-distance', and 'remote' fields, depending on their distance to the homestead.

Farm typology definition

The used methodology led to the distinction of five farm types (Fig. 3). Farms of type 1 are land-limited and the household head and/or any other family members work outside the farm earning a fixed salary or have a shop or another sort of off-farm income. This source of income is much higher than that generated by farming and therefore the main income for the household. Labour requirements are covered by hiring casual and sometimes permanent workers.

Type 2 farms are typically the large, wealthy farms with many family members and self-sufficient in terms of food production. Household heads of this type of farms tend to be older and getting to or already dividing their land for their sons. Plantations of a perennial cash crop like tea are seen more frequently in this type of farms.

Farms of type 3 are self-sufficient in food production, normally having surpluses for the market, and almost all their income is generated by farming. Activities that demand investments, like purchasing inputs required for growing cash crops are not widely adopted due to financial limitations. Household heads in this type of farms tend to be young to middle-aged and family size is normally in expansion. Sources of off-farm income are practically nil.

Type 4 farms are not self-sufficient in food production, normally land-limited and with low financial capacity to grow cash crops. Although it is the most heterogeneous group, a common denominator is that livestock keeping is one of the most relatively important farm activities in terms of labour allocation. As for Type 3 farms, off-farm income is rather intermittent. Characteristics of the household heads and family structure are also similar to that of farm type 3. Land limitation is, among others, the main difference between farm types 3 and 4.

Farms of type 5 are typically those land-limited farms in which more than one family member works for other farmers as casual labourers. This intermittent, low-skilled source of employment generates low wages for the household and creates an important labour shortage on their own farm. Such farms are not self-sufficient in food production. Although most of their income comes from off-farm sources, they differ clearly from the farm type 1 in terms of the relative importance of the cash and labour flows (i.e. labour:income ratios).

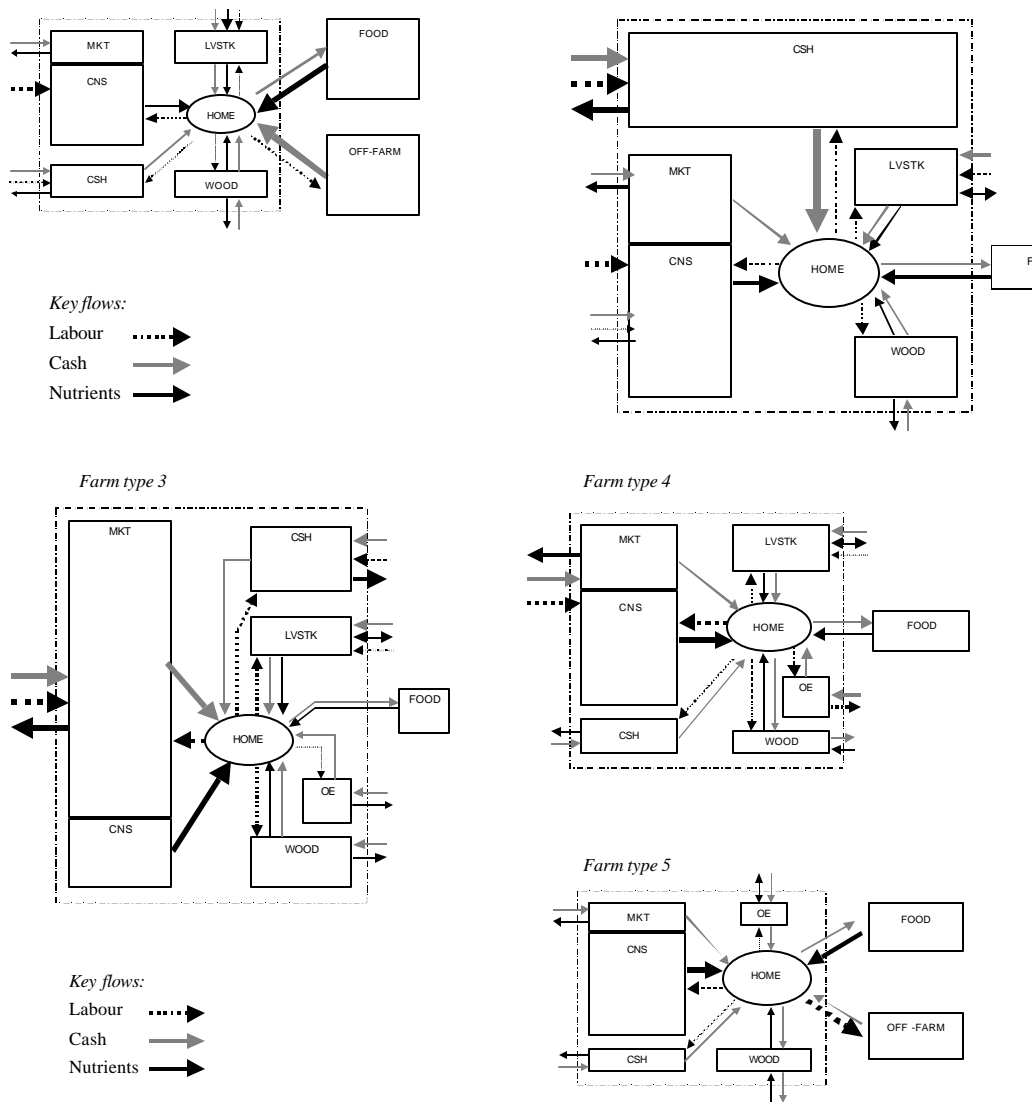

Fig. 3: Graphic models of farms of types 1 to 5 at Shinyalu, Kakamega. The sizes of the components as well as of the system boundaries indicate their relative size and/or importance in reality (e.g. the size of the homestead indicates family size; the size of the boundaries indicates land size). The weight of the arrows indicates the relative importance of the flows they symbolise. For the sake of simplicity not all possible flows are included. HOME: household (family size); CNS: food crops consumed by the household; MKT: surplus of food crop produce sold on the market; CSH: cash crops; LVSTK: livestock; WOOD: woodlot, mainly for fuel; FOOD: external source of food items (market); OFF-FARM: external source of income; OE: other enterprises, which comprise income-generating activities that involve on-farm production factors (e.g. honey bees, oxen-ploughing services, etc.).

Farm typology and fertilizer/organic resource use

Differentiating the mineral from the organic sources of N inputs, it is clear that the pattern of N allocation in Fig. 4 (from home gardens to remote fields) was mostly explained by the pattern of organic resource allocation. The distribution of N from mineral fertilisers was mainly affected by farm type: in the type 1 and type 2 case-study farms the remote fields received as much fertiliser N as the close fields. On the other hand, the N application rates were low for all field types in the case-study farms of types 3, 4 and 5. The distribution of N added through organic inputs was mainly affected by field type (Fig. 4), reflecting the effect of 'distance from the homestead'. However, the definition of field types may affect the interpretation of the results: apparently, the application rate of N in the organic inputs in the close fields was much higher for type 1 farms than for the other types. Due to

the smaller land size the close fields of the type 1 farms were much closer to the homestead and had a smaller area than in the type 2 farms, affecting the N application rates estimated for those fields

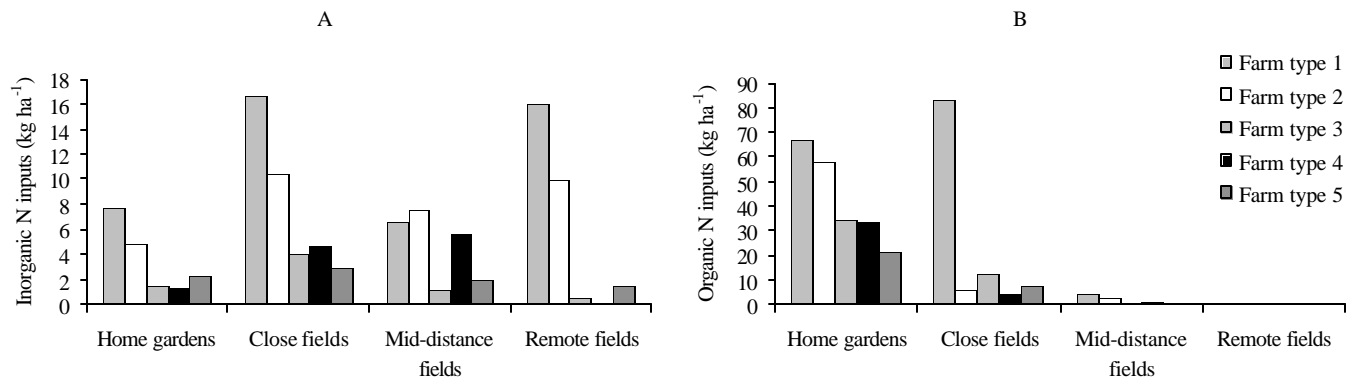

Figure. 4: N inputs in the different fields of the case study farm types 1 to 5 at Shinyalu, Western Kenya. A: N applied as mineral fertilisers; B: N applied as organic fertilisers. Estimations considering organic and mineral fertilisers in each field type according to the results of the resource-flow maps. Note the important differences in the scales of the y-axes.

Farms in Western Kenya are different and 5 distinct typologies could be identified. These varied in terms of production units present, land size off-farm cash income, and labour availability. Using data obtained through resource flow mapping, N inputs for different classes of fields were observed to vary considerably for the various fields and between the various typologies for the 'home garden' and 'close' fields, likely being one of the factors generating within-farm variability.

Activity 1.2. Improved understanding of soil processes regulating efficient nutrient cycling and organic matter dynamics.

Published work

Plant growth, mycorrhizal association, nutrient uptake and phosphorus dynamics in a volcanic-ash soil in Colombia as affected by the establishment of *Tithonia diversifolia*

S. Phiri^{1,2}, I.M. Rao², E. Barrios², and B.R. Singh¹

¹Agricultural University of Norway, P.O. Box 5028, NLH, N-1432 Aas, Norway

²Centro Internacional de Agricultura Tropical (CIAT), Apartado Aéreo 6713, Cali, Colombia

Journal of Sustainable Agriculture 21(3): 43-61

Tithonia diversifolia has the ability to sequester nutrients from soil in its tissues, including P, and has been shown to be useful for cycling nutrients via biomass transfer and improved fallow. We investigated the effects of its establishment from bare root seedlings (plantlets) and vegetative stem cuttings (stakes) on shoot and root growth characteristics, arbuscular-mycorrhizae (AM) associations, nutrient acquisition and utilisation, and P dynamics in a fine-textured volcanic-ash soil (Oxic Dystropept) of a mid-altitude hillside in southwestern Colombia. One year after establishment, the following determinations were made: leaf area index; shoot and root N, P, K, Ca and Mg acquisition; AM root infection; AM fungal spores per 100 g soil; soil chemical characteristics; and P fractionation into inorganic (P_i) and organic (P_o) pools. AM root infection in both coarse and fine roots was significantly greater in plants established from plantlets than those established from stakes with differences of 21 and 31 %, respectively. Nutrient uptake efficiency (?g of shoot nutrient uptake per m

of root length) and use efficiency (g of shoot biomass produced per g of shoot nutrient uptake) for N, P, K, Ca and Mg were also greater with plants established from plantlets than those established from stakes. (is it right). Improved nutrient acquisition could be attributed to relief from P stress and possibly uptake of some essential micronutrients resulting from AM association. High soil variability masked the effect of the establishment method on phosphorus pools, and neither the biologically available P (H_2O-P_o , resin- P_i , and $NaHCO_3-P_i$ and $-P_o$) nor the moderately resistant P (NaOH-extractable P) was significantly affected, although plantlets had higher values. This study has shown that on this soil when *Tithonia* is to be used as a fallow species, the use of plantlets as compared to the stake method of establishment is better for nutrient acquisition and recycling.

Plant growth, biomass production and nutrient accumulation by slash/mulch agroforestry systems in tropical hillsides of Colombia

E. Barrios and J.G. Cobo

Tropical Soil Biology and Fertility Institute, Centro Internacional de Agricultura Tropical (CIAT), Cali, Colombia. Agroforestry Systems (in press)

Planted fallow systems under 'slash and mulch' management were compared with natural fallow systems at two farms (BM1 and BM2) in the Colombian Andes. The BM1 site was relatively more fertile than the BM2 site. Planted fallow systems evaluated included *Calliandra calothyrsus* CIAT 20400 (CAL), *Indigofera constricta* (IND) or *Tithonia diversifolia* (TTH). During each pruning event slashed biomass was weighed, surface-applied to the soil on the same plot and sub-samples taken for chemical analyses. While *Indigofera* trees consistently showed significantly greater ($p < 0.05$) plant height and collar diameter than *Calliandra* trees at both study sites, only collar diameter in *Indigofera* was significantly affected at all sampling times by differences between BM1 and BM2. After 27 months, TTH presented the greatest cumulative dry weight biomass (37 t ha^{-1}) and nutrient accumulation in biomass ($417.5 \text{ kg N ha}^{-1}$, $85.3 \text{ kg P ha}^{-1}$, 928 kg K ha^{-1} , $299 \text{ kg Ca ha}^{-1}$ and $127.6 \text{ kg Mg ha}^{-1}$) among planted fallow systems studied at BM1. Leaf biomass was significantly greater ($P < 0.05$) for CAL than IND irrespective of site. However, CAL and IND biomass from other plant parts studied and nutrient accumulation were generally similar at BM1 and BM2. At both sites, NAT consistently presented the lowest biomass production and nutrient accumulation among planted fallow systems. Planted fallows using *Calliandra* and *Indigofera* trees had the additional benefit of producing considerable quantities of firewood for household use.

Root Distribution and Nutrient Uptake in Crop-forage Systems on Andean Hillsides

Q. Zhiping¹, I. M. Rao², J. Ricaurte², E. Amezquita², J. I. Sanz² and P. C. Kerridge²

¹*Tropical Field Crops and Animal Husbandry Research Institute, Chinese Academy of Tropical Agricultural Science (CATAS), 571737, Hainan, China.*

²*Centro Internacional de Agricultura Tropical (CIAT), A.A. 6713, Cali, Colombia.*

Journal of Sustainable Agriculture (in press)

Root growth and distribution of crop and forage components of production systems on hillsides could have important effects on nutrient acquisition and plant growth as well as on soil loss. A long-term field experiment was established in 1994 in the Andean hillsides region of Cauca, Colombia. Soils at the site are medium to fine textured Oxic Dystropepts derived from volcanic-ash deposits. Four treatments, cassava monocrop, cassava + cover legumes intercrop, elephant grass pasture, and imperial grass pasture, were selected to determine differences in dry matter partitioning, leaf area index, nutrient composition, root distribution (0-80 cm soil depth), nutrient acquisition and soil loss. Root biomass of the cassava + cover legumes intercrop was 44% greater than that of the cassava monocrop. The presence of cover legumes not only reduced soil erosion but also improved potassium acquisition by cassava. Among the two pastures, elephant grass pasture had greater root biomass (9.3 t ha^{-1}) than the imperial grass (4.2 t ha^{-1}). The greater root length density (per unit soil

volume) of the former contributed to superior acquisition of nitrogen, phosphorus, potassium and calcium from soil. In addition, the abundance of very fine roots in elephant grass pastures in the topsoil layers reduced the loss of soil from the steep slopes. These results indicate that (i) the presence of cover legumes can improve potassium acquisition by cassava; and (ii) elephant grass can be used as an effective grass barrier to reduce soil erosion in Andean hillsides.

Potential of ethylene-producing pseudomonads in combination with effective N₂-fixing bradyrhizobial strains as supplements to legume rotation for *Striga hermonthica* control

Monday O.Ahonsi, Dana K.Berner, Alphonse M.Emechebe, Segun T.Lagoke, and Nteranya Sanginga

IITA Ibadan Nigeria and TSBF-CIAT

Biological Control (2003) 28 (2003) 1–10

Striga hermonthica (Del.) Benth. is an obligate, root-parasitic, flowering plant that limits cereal production in sub-Saharan Africa. Successful control depends on eliminating its seed reserves in soil, thereby preventing parasitism. *Striga hermonthica* seeds germinate only if adequately conditioned and exogenous stimulant initiates ethylene production within the seed, or if ethylene is directly supplied to the conditioned seed. Since *S. hermonthica* is an obligate root parasite, stimulating the seeds to germinate in the absence of the host plants results in seedlings that die within 3–4 days (suicidal germination). Soil injection with ethylene gas is a proven method of eliminating *Striga spp.* seed reserves in soils, but its cost and potential hazard limit its use in Africa. Use of legume cultivars selected for their ability to cause suicidal germination of *S. hermonthica* seeds in rotation with cereal host is feasible, but effective reduction of parasite seeds in field soils normally requires several seasons of the legume crop. In this study, ethylene producing strains of *Pseudomonas sp.* in combination with N₂-fixing *Bradyrhizobia japonicum* strains were evaluated in pots as a supplement to legume rotation for *S. hermonthica* control. Co-inoculating cowpea cv.IT93K-637-1 or soybean cv.SAMSOY-2 with *Pseudomonas fluorescens* /*Pseudomonas putida* isolates that do not produce ethylene and with *B. japonicum* isolates either enhanced or had no effect on nodulation compared with *B. japonicum* alone. Co-inoculating cowpea or soybean with ethylene-producing *Pseudomonas syringae* pv. *glycinea* (Psg) and *B. japonicum* strains did not affect nodulation. While one or two preceding crops of cowpea or soybean reduced *S. hermonthica* parasitism on subsequent maize crops, the reductions were significantly improved by co-inoculating cowpea or soybean with Psg and *B. japonicum* strains. Psg and *B. japonicum* may have reduced *S. hermonthica* parasitism on maize by causing suicidal germination of *S. hermonthica* seeds and enhancing N₂-fixation. Results indicate that co-inoculating cowpea or soybean with ethylene-producing rhizosphere competent pseudomonads and N₂-fixing bradyrhizobia has potential to increase the effectiveness of legume rotation in reducing *S. hermonthica* parasitism on subsequent maize crops.

Phosphorus placement on acid arenosols of the West African Sahel

B. Muehlig-Versen¹, A. Buerker², A. Bationo³ and V. Roemheld¹

¹Institute of Plant Nutrition (330), University of Hohenheim, Stuttgart, Germany, ¹Institute of Crop Science, University of Kassel, Steinstr. Witzenhausen and ³TSBF-CIAT Nairobi, Kenya

Expl Agric. (2003), volume 39, pp. 307–325 C_ 2003 Cambridge University Press

Phosphorus (P) deficiency is a major constraint to pearl millet (*Pennisetum glaucum* L.) growth on acid sandy soils of the West African Sahel. To develop cost-effective fertilization strategies for cash poor farmers, experiments with pearl millet were conducted in southwestern Niger. Treatments comprised single superphosphate hill-placed at rates of 1, 3, 5 or 7 kg P ha⁻¹ factorially combined with broadcast P at a rate of 13 kg ha⁻¹. Nitrogen was applied as calcium ammonium nitrate at rates of 30 and 45 kg ha⁻¹. At low soil moisture, placement of single superphosphate in immediate proximity to the seed reduced seedling emergence. Despite these negative effects on germination, P

placement resulted in much faster growth of millet seedlings than did broadcast P. With P application, potassium nutrition of millet was improved and seedling nitrogen uptake increased two- to three-fold, indicating that nitrogen was not limiting early millet growth. Averaged over the 1995 and 1996 cropping seasons, placed applications of 3, 5 and 7 kg P ha⁻¹ led to 72%, 81% and 88% respectively, of the grain yield produced by broadcasting 13 kg P ha⁻¹. Nitrogen application did not show major effects on grain yield unless P requirements were met. A simple economic analysis revealed that the profitability of P application, defined as additional income per unit of fertilizer, was highest for P placement at 3 and 5 kg ha⁻¹.

The adoption of innovative methods to sustain and improve millet production in sub Saharan West Africa depends on the feasibility of the technique, the potential income gain from its implementation and the farmers' overall socio-economic situation. The consequence of subsistence-level farming, which in the past had been hidden by prolonged fallow periods, is the steady productivity decline of Sahelian soils. Counteracting soil nutrient depletion and subsequent land degradation while supplying enough food for the growing population of the Sahel, undoubtedly requires the application of external inputs. For millet, P placement with the seed offers an effective approach to overcome P deficiency. The application of SSP, however, entails the risk of salt injury to seedlings, especially under drought conditions. This problem might be avoided by using finely ground compound NPK fertilizer instead of SSP. Phosphorus placement at low rates can be easily adapted to the individual planting pattern of each farmer but it does not restore a soil's P reserves. To this end the combination of placed soluble P with locally available rock phosphate as a slow-release P source might offer a way to increase concurrently crop productivity and soil P reserves.

Phosphorus use efficiency as related to sources of P fertilizers, rainfall, soil and crop management in the West African Semi-Arid Tropics

Bationo A.¹, and K. Anand Kumar²

¹TSBF-CIAT, ²ICRISAT, Niamey – Niger.

The rainfall of agricultural areas of the West African Semi-Arid Tropics varies from 300 to 1200 mm. Although in absolute terms rainfall is low only in the Northern half of the desert margins, the high inter-annual variability associated with erratic distribution of rainfall in space and during the growing season constitute major limitation for agricultural production. Continuous and intensive cropping without restoration of the soil fertility has depleted the nutrient base of most of the soils. For many cropping systems in the region, nutrient balances are negative, indicating soil mining. Among soil fertility factors, phosphorus deficiency is a major constraint to crop production. Phosphorus use efficiency (PUE) is defined as yield increase per kg fertilizer P added, is related to P sources, environmental factors, soil and crop management.

In addition to water soluble P fertilizers, PR sources from Niger (Parc - W PR and Tahoua PR), Mali (Tilemsi PR) and Burkina Faso (Kodjari PR) and modified partially acidulated phosphate rocks (PAPR) effect on P-use efficiency is reported. PAPR improved the PUE of PR sources. Among the four PR sources in the region, Tahoua PR (TPR) recorded highest PUE as compared to Kodjari (KPR) or Parc-W (PRW) sources. Rainfall received in September at grain filling and maturation stage was best correlated to PUE. There is large difference in PUE of different pearl millet cultivars and values varied from 25 to 77 kg grain. Kg P⁻¹. The hill placement of 4 kg P.ha⁻¹ at planting time improved the PUE as compared to present recommendation of 13 kg.ha⁻¹ broadcast and also improved the efficiency of phosphate rock. The rotation of cereals and cowpea and soil amendment with crop residue application increase drastically the PUE in the region.

This study shows that the PUE is highly variable and depends on P sources, rainfall, soil and crop management. Previous agronomic research has already identified a significant number of

technologies to enhance PUE but future research needs to screen technologies under farmer's management in order to recommend with the highest economic returns. However there is little research on understanding the factors affecting P uptake such as the ability of plants to i) solubilize soil P through pH changes and the release of chelating agents and phosphates enzymes, ii) explore a large soil volume, and iii) absorb P from low soil solution P concentration.

A new method for the simultaneous measurement of pH-dependent cation exchange capacity and pH buffering capacity

K. Oorts¹, B. Vanlauwe³, J. Pleysier² and R. Merckx¹

¹ *Laboratory for Soil and Water Management, Faculty of Agricultural and Applied Biological Sciences, Leuven/Heverlee, Belgium.* ² *International Institute of Tropical Agriculture (IITA), Ibadan, Nigeria, TSBF-CIAT.*

The pH dependent cation exchange capacity (CEC) and pH buffering capacity (pH BC) are two crucial properties in soil fertility management of variable charge soils. However, they are rarely measured, since most of the existing methods are cumbersome and time consuming. We propose a new method, based on the silver-thiourea method, for the simultaneous measurement of pH dependent CEC and the pH BC. In general, this method consists of first increasing the pH of the soil to about pH 7 and then gradually acidifying the soil by titrating with HNO₃, while measuring pH and CEC after each equilibration. This way, both CEC at different pH values and the pH BC are measured on the same sample, without the multiple washing steps needed in other procedures. Various aspects of the proposed method were tested and the results obtained were compared to the ion adsorption method. The modified silver-thiourea method obtains field relevant results and is suitable for the routine analysis of large amounts of samples.

The study shows that the modified silver-thiourea method offers an attractive alternative to the ion adsorption methods for the measurement of CEC-pH relationships and pH buffering capacities. The method leads to CEC results that are identical to the results obtained by buffered AgTU solutions. The proposed method yields larger CEC values than the ion adsorption method at pH values below 5.5, whereas above this pH value both methods yield similar CEC values. This is ascribed to the very high selectivity of the silver-thiourea cation for the exchange sites in the soil. Further, the modified AgTU method avoids the multiple washing and equilibration steps involved in the classic ion adsorption methods, so eliminating the risk for dissolution and loss of charge bearing components during the procedure. Since both variable charge and pH buffering are partly controlled by the same exchange reactions in the soil, it is important to determine both properties simultaneously in exactly similar experimental conditions. Results for the pH buffering capacities obtained by the modified AgTU method agree well to values obtained by the ion adsorption method. The proposed modified AgTU method requires only one small soil sample for the simultaneous determination of both a complete picture of CEC variation with pH and a pH buffer curve. Compared to other methods, the proposed modified AgTU method strongly reduced the time and labour involved in determining the CEC-pH relationship and pH buffering capacity of a soil.

Integrated Soil Fertility Management research at TSBF: the framework, the principles, and their application

B Vanlauwe, TSBF-CIAT

Integrated Soil Fertility Management (ISFM) has been adopted by the Tropical Soil Biology and Fertility (TSBF) Institute, its African Network (AfNet), and various other organisations as the paradigm for tropical soil fertility management research and development. The development of ISFM is the result of a series of paradigm shifts generated through experience in the field and changes in the overall socio-economic and political environment the various stakeholders, including farmers and researchers, are facing. A first part of the paper illustrates these shifts and sketches how the science

of organic matter management has developed in the framework of the various paradigms. The second part focuses on the technical backbone of ISFM strategies by illustrating the roles of organic resources, mineral fertilizer, and soil organic matter (SOM) in providing soil-related goods and services. Special attention is given to the potential occurrence of positive interactions between these three factors, leading to added benefits in terms of more crop yield, improved soil fertility status, and/or reduced losses of C and nutrients to the environment. A third part aims at confronting the principles and mechanisms for soil fertility management, highlighted in the second section, with reality and focuses on the impact of other realms of capital on soil management opportunities and the potential of decision aids to translate all knowledge and information in a format accessible to the various stakeholders.

Efficacy of soil organic matter fractionation methods for soils of different texture under similar management.

Pauline P. Chivenge^{1}, Herbert K. Murwira¹ and Ken E. Giller²*

¹*Tropical Soil Biology and Fertility (TSBF), Harare, Zimbabwe.*

²*Soil Science and Agricultural Engineering Department, Faculty of Agriculture, University of Zimbabwe*

High soil dispersion is essential for the effectiveness of physical soil organic matter fractionation methods based on fraction size and/or density. A study was conducted to test the use of two dispersing agents, sodium resin bags and sodium hexametaphosphate for organic matter fractionation in two soils, a sand and a red clay soil. Two concentrations of sodium hexametaphosphate, 0.5% and 2% were used, and for the 2% concentration another treatment of pre-soaking versus not soaking was added.

Complete dispersion was achieved with all the dispersing agents used for the sandy soil. For the red clay soil none of the dispersing agents used achieved complete dispersion. Compared with the sodium hexametaphosphate, sodium resin bags resulted in a three-fold decrease in the amounts of coarse organic matter fractions for both the sand and the red clay soils. The use of resin bags resulted in a decrease in the amount of organic C in the coarse sand (212-2000 μm) and the medium sand (53-212 μm) fractions. There were however no differences in the amounts of the mineral fractions obtained by using the two dispersing agents for the two soil types.

Increasing the concentration of sodium hexametaphosphate did not result in an increase in soil dispersion for both the sand and red clay soils. There were no differences in the amounts of organic and mineral fractions obtained using the two concentrations for both the sand and red clay soils. Pre-soaking the soil resulted in an increase in soil dispersion reflected by a decrease in the amount of coarse sand and medium sand mineral fractions for the red clay soil. There were no effects on soil dispersion caused by soaking on the sandy soil. There were however no differences in the amounts of coarse and medium sand organic matter fractions obtained before and after soaking the soil. We concluded that using 0.5% sodium hexametaphosphate after soaking the soil was the most appropriate dispersing agent to use for achieving high soil dispersion without altering the soil organic matter distribution in the various size fractions for the red clay and the sandy soils.

Nitrogen mineralisation from aerobically and anaerobically treated cattle manures

J.K. Nzuma¹ and H. K. Murwira².

¹*Department of Soil Science, University of Zimbabwe*

²*TSBF-CIAT*

Short-term mineralisation-immobilisation turnover of N after amending soil with aerobic and anaerobic manures treated in April and July with or without straw was studied during a 77-day incubation period using the leaching tube method. The dynamics of N mineralisation were described

by first order kinetics with high rate constants for anaerobic manures without straw treated in July.

Results showed significant variations in the decomposition of manures from different storage conditions. Differences in the rate constants between the manures reflected initial short term variations in the inorganic-N content of the readily decomposable fractions. Anaerobic manures with their high initial NH₄-N contents were found to have highest rate constants than aerobic manures.

The decomposition of anaerobic manures in soil almost always resulted in temporal initial immobilization. The immobilisation period was lengthened in manures with straw and by the age of manure owing to duration of storage. In spite of the initial immobilisation of the inorganic N that occurred in soil with these manures, re-mineralization occurred close to the rapid crop growth stage reflecting that these manures may be synchronized with crop N requirements in the short term.

Little or no N was mineralised from aerobic manures. The implications are that these manures could be an inefficient source of fertiliser N for the crop. Though N released by these manures may be asynchronous with maize crop N requirements in the short term, the proportion of the N that still remains in organic bound form could be available for transformation in the residual years.

Influence of tillage management practices on organic carbon distribution in particle size fractions of a chromic luvisol and an areni-gleyic luvisol in Zimbabwe

P. P. Chivenge¹, H. K. Murwira¹ and K. E. Giller²

¹TSBF-CIAT, Pleasant, Harare, Zimbabwe. and ²Plant Production Systems, Department of Plant Sciences, Wageningen University, The Netherlands

Long-term tillage effects on soil organic matter dynamics were evaluated for a Chromic Luvisol (red clay soil) and Areni-Gleyic Luvisol (sandy soil) in Zimbabwe. The soils had been under conventional tillage, mulch ripping, clean ripping and tied ridging for at least nine years. Clay soil had about three times more soil organic matter than the sandy soil because of better physical protection of organic matter. Conventional tillage caused the highest organic C decline of 47% and 61% for the red clay and sandy soils, respectively. The highest organic C content of 0.68% in the sandy soil was under mulch ripping whilst for the red clay soil tied ridging had the highest content of 2.04%. These values were, however low, when compared with the weedy fallow which was 1.13% and 2.79% total organic C soil for the sandy and red clay soils, respectively. This indicates preservation and lower losses of organic matter in the weedy fallow. Conventional tillage reduced organic C in the coarse fractions by up to 78% and 84% for the red clay and sandy soils, respectively. Clay size fractions were the most stable fractions because of physical protection from microbial attack and this was shown by their small responses to tillage. Most of the organic matter was associated with the finer fractions for the red clay soil while for the sandy soil the greater proportion of the organic matter was associated with the sand fractions.

Nitrogen fertilizer equivalencies of organics of differing quality and optimum combination with inorganic nitrogen source in Central Kenya

**J.M. Kimetu¹, D.N. Mugendi², C.A. Palm¹, P.K. Mutuo¹, C.N. Gachengo¹, A. Bationo¹, S. Nandwa³, J.B. Kungu²*

¹Tropical Soil Biology and Fertility Institute of CIAT (TSBF-CIAT), ² Department of Environmental Foundations, Kenyatta University, Nairobi, Kenya ³National Agricultural Research Laboratories (NARL), Nairobi, Kenya

A field experiment was set up in the sub-humid highlands of Kenya to establish the chemical fertilizer equivalency values of different organic materials based on their quality. The experiment consisted of maize plots to which freshly collected leaves of *Tithonia diversifolia* (tithonia), *Senna spectabilis* (senna) and *Calliandra calothyrsus* (calliandra) (all with % N >3) obtained from hedgerows grown ex

situ (biomass transfer) and urea (inorganic nitrogen source) were applied. Results obtained for the cumulative above ground biomass yield for three seasons indicated that a combination of both organic and inorganic nutrient source gave higher maize biomass yield than when each was applied separately.

Above ground biomass yield production in maize (t ha⁻¹) from organic and inorganic fertilization was in the order of senna+urea (31.2), tithonia+urea (29.4), calliandra+urea (29.3), tithonia (28.6), senna (27.9), urea (27.4), calliandra (25.9), and control (22.5) for three cumulative seasons. On average, the three organic materials (calliandra, senna and tithonia) gave fertilizer equivalency values for the nitrogen contained in them of 50%, 87% and 118% respectively. It is therefore recommended that tithonia biomass can be used in place of mineral fertilizer as a source of nitrogen. The high equivalency values can be attributed to the synergetic effects of nutrient supply, and improved moisture and soil physical conditions of the mulch. However, for sustainable agricultural production, combination with mineral fertilizer could be the best option.

However, there are some limitations in the use of organics which include: Requirement of large quantities and associate labor demand; Variable quality constraining the use predictability with respect to the Organic Resource Database (ORD) decision tree; Little economic returns when the organics are not used on high value crops; and limited information about the right proportions of application.

The potential of Ipomoea stenosiphon as soil fertility ameliorant in Zimbabwe: a comparison with other agroforestry species

*T. Mombeyarara*¹ and *H. K Murwira*^{2*}

¹Department of Soil Science and Agricultural Engineering, University of Zimbabwe and ²TSBF-CAIT, Zimbabwe

Ipomoea stenosiphon (Hallier) A.Meeuse (local name-Gubvuwa), a plant species indigenous to Zimbabwe was studied to identify its potential to improve soil fertility in comparison with other agroforestry species which included *Leucaena leucocephala*, *Acacia angustissima*, *Leucaena pallida*, *Calliandra calothyrsus*, *Leucaena esculenta*, *Cajanus cajan*, *Lablab purpureus*, *Macroptilium atropurpureum* and *Leucaena diversifolia*. *Ipomoea stenosiphon* significantly mineralised more nitrogen (P<0.05) compared to the other species except for *Leucaena leucocephala* and *Acacia angustissima*. This is because of their higher N content of 3.23% and 3.03% respectively compared to 2.27% for *Ipomoea stenosiphon*. There was a positive correlation between the initial plant N content and the amount of net N mineralised ($r^2=0.86$). The critical N content for N release was 2.1%N for the plant materials tested. In a greenhouse study, *Ipomoea stenosiphon* produced the highest dry matter yield but there was no significant difference with other agroforestry species (P<0.05) except *Lablab purpureus*, which produced lower biomass yield. It was concluded that *Ipomoea stenosiphon* had potential to improve soil fertility, and its high P content could have increased dry matter yield when the same N application rate was used.

Completed work

Dynamics of charge bearing soil organic matter fractions in highly weathered soils

*Koen Oorts*¹, *Roel Merckx*¹, *Bernard Vanlauwe*², *Nteranya Sanginga*³ and *Jan Diels*³

¹K.U. Leuven, Department of Land Management, ²Tropical Soil Biology and Fertility Program,

³International Institute of Tropical Agriculture,

Soil organic matter contributes significantly to cation exchange capacity, especially in highly weathered soils, where it can account for up to 90% of the total CEC of the topsoil. To determine how different amounts and qualities of plant residues affect the development of charge in these soils,

we set out to (i) determine the effects of litter quality on the development of charge in soil and in its size separates and to (ii) determine the dynamics of this phenomenon in the field. For (i) we relied on a 20-year old arboretum where we collected soil samples under seven multipurpose tree species: *Azelia africana*, *Dactyladenia barteri*, *Gliricidia sepium*, *Gmelina arborea*, *Leucaena leucocephala*, *Pterocarpus santalinoides*, and *Treculia africana*. For (ii) we installed decomposition tubes in the field with six treatments (control and *Azelia*, *Dactyladenia*, *Gmelina*, *Leucaena* and *Treculia* at 15 Mg dry matter ha⁻¹) and followed the development of charge in the top 10 cm over a period of two years. Samples from both experiments were dispersed by ultrasound and then physically fractionated by wet sieving and sedimentation. CEC measurements were made at 6 different pH values between 7.5 and 2.5 with the silver-thiourea method.

In the arboretum samples, carbon contents and CEC at in situ pH ranged between 7.16 and 13.62 g C kg⁻¹ soil and between 2.8 and 6.5 cmol_c kg⁻¹ soil respectively. The clay and fine silt fractions were responsible for 76 to 90% of the soil CEC at pH 5.8. The contribution of the fine silt fraction to this CEC ranged from 35% to 50%. After 20 years, the fine silt reflected the treatment differences most clearly (Carbon: 34.1 – 65.8 g C kg⁻¹ fraction and CEC: 16 - 36 cmol_c kg⁻¹ fraction at pH 6). The clay fraction seemed to be unaffected by the different organic inputs as it did not show clear differences in carbon content and CEC between treatments. Carbon content and pH together explained more than 85 % of the variation in CEC for the whole soil and the fractions. Differences in CEC between treatments could, as a consequence, be explained by the differences in carbon content. In total, SOM was responsible for 75 to 85% of the CEC of these soils.

The decomposition tube experiment revealed that after 23 months total soil carbon contents ranged between 3.8 and 5.3 g C kg⁻¹ soil while CEC values at pH 5 (=average pH) ranged between 1.9 and 2.5 cmol_c kg⁻¹ soil. Fine silt carbon contents ranged between 18.3 and 26.5 g C kg⁻¹ fine silt and CEC values at pH 5 varied between 5.3 and 8.9 cmol_c kg⁻¹ fine silt. Fine silt fractions again reflected the differences between the treatments most clearly, indicating that the lowest quality residues such as *Treculia* and *Dactyladenia* resulted in the largest CEC values and the largest carbon contents. While the results from the first experiment confirm a role of low quality residues in the build-up of charge in weathered soils after 20 years, the second experiment indicates that even a single addition of these residues enhances charge characteristics significantly and for a significant length of time.

In conclusion both parts of the experimental program confirm the strong relation between soil organic matter and charge development in highly weathered soils, such as the ferric Lixisol in Ibadan, Nigeria. In the soil derived from the arboretum, after 20 years of continuous input of litters widely ranging in nitrogen, lignin and polyphenol contents, large differences in organic matter resulted with concomitant large differences in CEC. Because differences in CEC could be explained almost completely by the variation in soil organic carbon concentration, the effect of residue inputs was judged indirect. Differences in CEC were due to changes in the silt fractions predominantly, indicating that changes in clay fractions are not readily obtained in a time-span of less than 20 years. The decomposition tube experiment was completely in line with the above findings in this that a low quality residue proved instrumental in enhancing charge in these soils. Yet it also demonstrated that such effects could be obtained already after a single addition of 15 Mg/ha and that they were still obvious almost two years after this addition.

Improvement of phosphorus availability in West African moist savanna soils: the impact of residue characteristics

O.C. Nwoke^{1,3}, B. Vanlauwe², J. Diels¹, N. Sanginga², O. Osonubi³

¹Soil Microbiology Unit, IITA, Ibadan, Nigeria, ²TSBF-CIAT, Nairobi, Kenya;

³Department of Botany and Microbiology, University of Ibadan, Ibadan, Nigeria

While some residue parameters that control the rates of decomposition and N release have been identified, their importance in P release is poorly understood. The role of residue characteristics in enhancing the availability of P was investigated in a greenhouse study using 2 soils from the northern Guinea savanna (NGS) and 4 from the derived savanna (DS) zones of the West African moist savanna. Eight organic residues of varying C-to-P ratios were used and maize (*Zea mays*) was grown for 7 weeks. The effect of the organic residues on P availability (measured as resin P and maize P uptake) differed among the soils. On average, the increase in resin P, calculated as $[(\text{Soil} + \text{Residue}) - \text{Control}] / (\text{Control}) \times 100$, was between 8 % (Davié, DS) and 355 % (Danayamaka, NGS). Maize P uptake was raised in the range of 11 % in Davié and Niaouli (DS) soils and 600% in Danayamaka soil. The increase in maize dry matter yield (DMY) ranged from 2 to 649 %. Residues with C-to-P ratios above 200 produced lower DMY than those with lower ratios. Residue organic P (Po) extractable with 0.2 N H₂SO₄ (acid-Po) accounted for 92 % ($P < 0.001$) of the variation in DMY in a step-wise regression. The residue Po extractable with 0.5 M NaHCO₃ (HCO₃-Po) correlated significantly with DMY in Danayamaka and Davié soils, and with P uptake in Danayamaka soil. Resin P correlated ($P < 0.05$) with the C-to-P ratio in Ibadan (DS) soil and with the soluble C content in Sarakawa (DS) soil. It also correlated with the water-soluble fraction ($P < 0.05$) in Kasuwan Magani (NGS), Sarakawa (DS) and Davié soils. The relationships between the residue Po and DMY might imply that Po fractions in decomposing residues contribute to P availability. However, the suitability of using the Po content of organic residues to predict their agronomic value with respect to P nutrition needs further evaluation.

Rapid characterization of Organic Resource Quality for Soil and Livestock :Management in Tropical Agroecosystems Using Near Infrared Spectroscopy

Keith D Shepherd¹, Cheryl A. Palm², Catherine N. Gacheng², and Bernard Vanlauwe²

World Agroforestry Centre Nairobi, and Tropical Soil Biology and Fertility Institute of CIAT, Kenya.

Organic resources constitute a major source of nutrient inputs to both soils and livestock in smallholder tropical production systems. Determination of resource quality attributes using current laboratory methods is both timely and costly. This study tested visible and near infrared (wavelengths from 0.35 to 2.50 μm) reflectance spectroscopy (NIRS) for rapid prediction of quality attributes for a diverse range of organic resources. A spectral library was constructed for 319 samples of oven-dried, ground plant material originating from green leaf (186 samples), litter (33), root (25), and stem (21) samples from 83 species including tropical crops and trees used for agroforestry, and manure samples (39). Organic resource attributes were calibrated to first derivative reflectance using regression trees with stochastic gradient boosting, and screening tests were developed for separating various organic resource quality classes using classification trees. Validation r^2 values for actual versus predicted values using a 25% hold-out sample were 0.91 for nitrogen, 0.90 for total soluble polyphenol, and 0.64 for lignin concentration. Screening tests gave validation prediction efficiencies of 96% for detecting samples with high N concentration, 91% for low total soluble polyphenol, and 86% for low lignin concentration. The spectral screening tests were robust even at small ($n = 48$) calibrations sample sizes. Screening tests for detecting samples with low or high levels of P, K, Ca and Mg gave prediction efficiencies of 74 to 92%. NIRS can be used to rapidly screen organic resource quality. Global spectral calibration libraries should be established for a range of resource quality attributes.

It is concluded that near infrared spectroscopy can provide rapid and accurate prediction of N and total soluble polyphenol concentrations with a single global calibration across a wide range of organic resources. Because these variables are principal determinants of N mineralization and immobilization rates among organic resources, spectral screening tests can be used to characterize this aspect of resource quality. Spectral screening tests of moderate accuracy can also be developed for diverse organic resource materials that identify samples with high or low concentrations of lignin and minerals. NIRS prediction of N concentration and screening of organic resource quality is of potential value in studies where large numbers of samples are needed and will allow variability to be more adequately sampled than with conventional approaches. Thus NIRS may be useful in studies on management of organic resource inputs by farmers, in nutrient budget studies, for determination of fodder quality, and for routine testing for advisory purposes. Where more accurate measurements are required, spectral screening may allow reduction in costs of conventional laboratory determinations by providing a means of sample stratification.

We recommend that the organic resource database concept of Palm et al. (2001) and similar work by Jensen et al. (2002) be extended to include a global spectral library with calibrations, as suggested for soil spectral libraries by Shepherd and Walsh (2002). In this way spectral outliers detected among new samples can be added to the calibration libraries, thereby increasing the predictive value of the spectral library for global use as new samples are added. This would be much more efficient than current practice where data from samples analyzed in different laboratories around the world have no value beyond the immediate study of interest. Future studies should test calibration of decomposition characteristics directly to near infrared reflectance and also compare NIRS predictive accuracy with standard errors of duplication for standard chemical reference analyses.

Evaluation of ultrasonic dispersion for the isolation of soil organic matter fractions in highly weathered soils

K. Oorts¹, B. Vanlauwe², S. Recous³ & R. Merckx¹

¹Laboratory for Soil and Water Management, Faculty of Agricultural and Applied Biological Sciences, Leuven/Heverlee, Belgium, ² Tropical Soil Biology and Fertility Program, , Nairobi, Kenya, and ³INRA, Unité d'Agronomie Laon-Reims-Mons, France.

Ultrasonic dispersion is widely used in soil organic matter (SOM) fractionation studies. However, a standard procedure does not exist and the effectiveness of the method depends on soil properties. The use of high energies also entails the risk for redistribution of particulate organic matter (POM) to smaller particle-size fractions. Therefore we aimed i) to determine the energy needed for complete dispersion of highly weathered soils from West Africa and ii) to study the redistribution of POM in function of dispersion intensity. Three soils were dispersed at different ultrasonic energies (750, 1500 and 2250 J g⁻¹ soil) or with sodium carbonate and were fractionated based on particle-size. Fraction yields were compared with those obtained with a standard particle-size analysis after removal of soil organic matter.

Chemical dispersion with sodium carbonate resulted in the weakest dispersion and affected the chemical properties of the obtained fractions through its high pH and the introduction of carbonate. The application of an increasing amount of ultrasonic energy resulted in an increasing degree of dispersion, but it also caused an increasing redistribution of the particulate organic matter to smaller particle size fractions. An ultrasonic dispersion at 1500 J g⁻¹ soil obtained a near complete dispersion down to the clay level (0.002 mm), compared to the particle-size analysis, and it only resulted in a limited redistribution of the POM fraction to smaller fractions. The milder ultrasonic dispersion treatment (750 J g⁻¹) did not result in adequate soil dispersion as too much clay was still recovered in the silt fractions. The 2250 J g⁻¹ treatment obtained the best dispersion compared to a standard

particle-size analysis, but this treatment was too destructive for the POM fractions since it redistributed respectively up to 31 and 37% of the total amount of carbon and nitrogen in these POM fractions to smaller particle-size fractions. It is concluded that, for the three highly weathered soils tested, an ultrasonic dispersion at 1500 J g⁻¹ best met the criteria of a good dispersion method for SOM studies.

Redistribution of particulate organic matter in different states of decomposition during ultrasonic dispersion

K. Oort¹, B. Vanlauwe², S. Recous³ & R. Merck¹

¹ *Laboratory for Soil and Water Management, Faculty of Agricultural and Applied Biological Sciences Leuven/Heverlee, Belgium,* ² *Tropical Soil Biology and Fertility Program, Unesco-Gigiri, , Nairobi, Kenya,* and ³ *INRA, Unité d'Agronomie Laon-Reims-Mons, , France.*

The use of ultrasonic energy for the dispersion of aggregates in soil organic matter (SOM) fractionation studies entails a risk for redistribution of particulate organic matter (POM) to smaller particle-size fractions. As the mechanical strength of straw decreases with increasing state of decomposition, it can be expected that not all POM will be redistributed to the same extent during ultrasonic dispersion. Therefore we studied the redistribution of POM in function of its state of decomposition. Undecomposed or incubated (for 2, 4, or 6 months) ¹³C enriched wheat straw was added to the POM fraction (0.25 – 2 mm) of a Ferric Lixisol and soil samples were dispersed at 1500 J g⁻¹ and fractionated based on particle-size. The amount of POM redistributed to smaller particle-size fractions during ultrasonic dispersion increased with increasing incubation time of this POM. Straw particles incubated for 6 months were even completely transferred to smaller particle-size fractions. Therefore, ultrasonic dispersion resulted in a fractionation of POM, leaving only the less decomposed particles in this fraction. The amounts of carbon and nitrogen transferred to the silt and clay fractions were however negligible compared to the total amounts of carbon and nitrogen in these fractions. It is concluded that complete ultrasonic dispersion is not suitable for the isolation of POM fractions. However, it is still considered as an acceptable and appropriate method for the isolation and study of SOM associated with silt and clay fractions.

Resource flows and nutrient balances in smallholder farming systems in Mayuge district, eastern Uganda.

A.O. Esilaba, P. Nyende, G. Nalukenge, J.B. Byalebeka, R.J. Delve and H. Ssali.
Agroecosystems and Environment (Submitted)

Resource flows and farm nutrient balance studies were carried out in eastern Uganda to ascertain the movement of organic resources and nutrients in and out of the farm system. Resource flow mapping was conducted during a participatory learning and action research (PLAR) process. The resource flows were transformed into nutrient flows and partial nutrient balances were calculated for the crop production, animal production, household and out of farm systems using the Resource Kit computer package. Results of a farmers' soil fertility management classification at the start of the PLAR intervention in 1999 revealed that 3% of the farmers were good soil fertility managers, 10 % were average soil fertility managers (class II) and 87% were poor soil fertility managers (class III). There was a strong relationship between wealth ranking according to the farmers' own criteria and soil fertility management classification.

Soil chemical and physical properties of the soils in the three soil fertility management classes did not differ significantly despite the differences perceived by the farmers. The study revealed that very low quantities of resources and nutrients enter the farm system, but substantial amounts leave the farm in crop harvests. The main source of nutrients on the farm is the crop production system and the major

destination is the household system. The livestock component contributed little to the flow of nutrients in the farm system due to the low levels of livestock ownership.

The results indicate that the net farm nutrient balances kg ha^{-1} per season for all the nutrients (N, P, and K) were negative for both the good and the poor soil fertility managers. Class 1 farm balances irrespective of the season, were however more negative than those of class 3 farms. For the long rains seasons (LR 2000,2001 and 2002), the average net farm nutrient balances for N, P, and K for class I farms were -5.0, -0.6 and - 8.0 $\text{kg ha}^{-1} \text{ year}^{-1}$, while for the short rains seasons (SR 2000 and 2001), the nutrient balances were -3.5, - 0.5 and -6.0 $\text{kg ha}^{-1} \text{ year}^{-1}$ respectively. For the class III farms, the average net farm nutrient balances for N, P, and K in the long rain seasons (LR 2000,2001 and 2002) were -3.3, -0.3 and -4.0 $\text{kg ha}^{-1} \text{ year}^{-1}$ while for the short rains seasons (SR 2000 and 2001), the nutrient balances were -3.5, 0.5 and -5.0 $\text{kg ha}^{-1} \text{ year}^{-1}$ respectively. The partial nutrient balances for the various subsystems in the short rains for class 1 farmers were lower than those of the long rains season. Significant nutrient loss occurred in the crop production system as almost no nutrients return to the system. Potassium export from the farm was severe especially for farmers who sell a lot of banana. Soil management interventions for these small-scale farmers should aim at reversing nutrient depletion with a focus on profitable management of the crop production system, which is the major cause of nutrient depletion. Strategic management of nutrients that enter the household system such as through home gardening and composting near the household would greatly increase the return of nutrients to the crop production system.

On-farm testing of integrated nutrient management strategies in Eastern Uganda

A.O Esilaba, J.B. Byalebeka, R.J Delve, J.R. Okalebo, D. Ssenyange, M. Mbalule, and H. Ssali. Agricultural Systems. (Submitted)

This paper reports on a Participatory Learning and Action Research (PLAR) process that was initiated in three villages in Eastern Uganda in September 1999 to enable small-scale farmers to profitably reverse nutrient depletion of their soils by increasing their capacity to develop, adapt and use integrated natural resource management strategies. The PLAR process was also used to improve the participatory skills and tools of research and extension personnel to support this process. The farming systems of the area were characterised for socio-economic and biophysical conditions that included social organisations, wealth categories, gender, crop, soil, agroforestry and livestock production. Farmers identified soil fertility constraints, indicators and causes of soil fertility decline and suggested strategies to address the problem of soil fertility decline. Soil fertility management diversity among households indicated that most farmers were not carrying out any improved soil fertility management practices, despite previous research and dissemination in the area. Following the diagnosis stage and exposure visits to other farmer groups working on integrated soil fertility projects, the farmer's designed eleven experiments for on-farm testing. One hundred and twenty farmers then chose, for participatory technology development, sub-sets of these eleven experiments, based on the main agricultural constraints and potential solutions identified and prioritised by the farmers. Quantitative and qualitative results from the testing, farmer evaluation and adaptation, training, dissemination strategies and socio-economic implications of these technologies are discussed.

Impact of crop-forage-fallow systems on soil P dynamics, acquisition and cycling in low fertility soils of Latin America.

I.M.Rao¹, E. Barrios¹, E. Amézquita¹, D. K. Friesen², R.J. Thomas¹³, A. Oberson⁴, B. R. Singh⁵

¹ Tropical Soil Biology and Fertility Institute, Centro Internacional de Agricultura Tropical (CIAT). Cali, Colombia;

² CIMMYT-IFDC, Nairobi, Kenya; ³ ICARDA, Aleppo, Siria; ⁴ ETH, Switzerland and ⁵ AUN, Norway

Phosphorus (P) deficiency is a widespread nutrient constraint to crop production on tropical and sub-tropical soils and it impacts an area estimated at over 2 billion ha. However, for most resource-poor

farmers in developing countries, correcting soil P deficiency with large applications of P fertilizer is not a viable option. Furthermore, the inexpensive rock phosphate reserves remaining in the world could be depleted in as little as 60 to 80 years. Therefore, sustainable P management in agriculture requires that additional information on the mechanisms in plants that enhance P acquisition be obtained in order to make plants more efficient at acquiring P, develop P efficient germplasm, and advance crop management schemes that increase soil P availability.

Since 1993, CIAT researchers in collaboration with NARS partners have conducted long-term field studies on soil P dynamics, acquisition and cycling in crop-pasture-fallow systems of low fertility soils of the tropical savannas and hillsides agroecosystems in Colombia. The synthesis of progress made from these long-term studies is described below.

Tropical savannas agroecosystem – Llanos of Colombia

Comparison of rooting patterns of crop and forage components indicated that introduced legume-based pastures are more deep rooted than crops and acquire considerable amounts of P despite a much lower level of available P in the surface soil. Studies on root distribution of maize showed that most of the roots are in top 20 cm of soil depth. These differences in rooting strategies have important implications for P acquisition efficiency in relation to available soil P in different crop and pasture systems (Table 4). Accessible P recovery was markedly greater with introduced and native pasture systems than that of maize monoculture. Application of higher amounts of lime did not improve subsoil-rooting ability of maize but contributed to greater nutrient acquisition. Cultivation with disc harrow (8 passes) markedly improved maize growth and nutrient acquisition. Observed differences in crop/forage residue decomposition and P release rates suggested that managing the interaction of residue with soil could help reducing P fixation reactions. Measurements of soil P fractions indicated that applied P moves preferentially into labile inorganic P pools, and then only slowly via biomass production and microbes into organic P pools under both introduced pastures and crop rotations.

Table 4. Differences among crop and pasture systems in P acquisition efficiency in relation to available soil P.

System	Bray-II available P (mg kg ⁻¹)	Total root length (km m ⁻²)	Specific root length (m g ⁻¹)	Total uptake (kg ha ⁻¹)	P Accessible P recovery ¹ (%)
Native savanna pasture	1.6	5.8	122	4	74
Introduced grass / legumes pasture ²	3.5	7.2	75	14	94
Maize monoculture ³	19.8	4.8	106	18	24

¹Total P uptake per unit available P in rhizosphere soil (assuming an effective rhizosphere diameter of 5 mm).

²*Brachiaria humidicola* CIAT 679 / *Stylosanthes capitata* CIAT 10280 + *Centrosema acutifolium* CIAT 5277 + *Arachis pintoi* CIAT 17434

³*Zea mays* cv. Sikuani 3

Agricultural land-use systems replacing native savanna on Oxisols affect the partitioning of P among inorganic and organic P fractions. Indicators of organic P mineralization suggest that organic P is more important for delivering available P in improved grass-legume pastures than in continuously cropped soils. In cultivated soils, much higher P fertilizer doses significantly increase available inorganic P contents with lesser impact of organic P pool sizes. We found that the amount and turnover of P that is held in the soil microbial biomass is increased when native savanna is replaced by improved pasture while it was lowered when soils are cultivated and cropped continuously. Based on these studies, we suggest an alternative strategy to cropping low P Oxisols. This strategy involves strategic application of lower amounts of P fertilizer to crops and planting of grass-legume pastures to promote P cycling and efficient use of P inputs.

Techniques using the principle of isotopic exchange allow measurement of the amount of orthophosphate that can be transferred from the soil solid phase to the soil solution in a given time and therefore, give information on soil P availability. We tested the usefulness of these improved isotope techniques to assess availability of P in acid soils containing low P. We found that these approaches are not precise enough to detect in these soils the ability of a plant to access slowly exchangeable forms of P or to quantify the mineralization of organic P. However, these isotope techniques can be used to estimate the total fraction of added fertilizer P that remains available to the plant.

We also tested the effect of agricultural land use and related P fertilizer inputs on size of P fractions and their isotopic exchangeability. We found that resin-P_i, Bic-P_i, NaOH-P_i and hot HCl-P_i increase with P fertilization, with highest increase for NaOH-P_i. The recovery of ³³P in the two soils with annual fertilizer inputs and large positive input-output P balances indicate that resin-P_i, Bic-P_i and NaOH-P_i contained most of the exchangeable P. In these soils the labeled ³³P moved with increasing incubation time from the resin to the Bic-P_i and NaOH-P_i fraction. As the ³¹P content of these fractions remained constant, the transfer of ³³P suggests P exchange among these fractions. The organic or more recalcitrant inorganic fractions contained almost no exchangeable P. In contrast, in soils with low or no P fertilization, more than 14% of added ³³P was recovered in NaOH-P_o and HCl-P_o fractions two weeks after labeling, showing that organic P is involved in short term P dynamics.

Studies on P cycling in long-term (16-year-old) introduced pastures in the Llanos of Colombia indicated that legume-based pastures maintain higher organic and available P levels more consistently than the grass alone or native pastures. Greater turnover of roots and above-ground litter in legume-based pastures could provide for steadier organic inputs and, therefore, higher P cycling and availability. Failure of P to enter organic P pools is thought to indicate a degrading system due to low level of P cycling. If that is true, work done so far in the Llanos of Colombia indicate that legume-based pastures could be considered as important land use options to stimulate P cycling, reduce P fixation and minimize soil degradation in tropical savannas.

Field studies were also conducted to quantify the residual effectiveness of P fertilizer inputs in cereal-grain legume rotations (Maize-soybean or rice-cowpea) in terms of both crop growth response and labile P pool sizes in an oxisol in the Llanos of Colombia. The results showed that soluble P applications to oxisols of Colombia remain available for periods of time which are much longer than expected for "high P-fixing" soils, such as the oxisols of Brazilian Cerrados. Using isotope techniques, we also showed greater residual value of fertilizer P applications to an oxisol in the Llanos.

We compared acid ammonium oxalate extraction method with Bray-II extraction, resin and bicarbonate extraction, and extraction with iron-impregnated paper strips for determining the available P in low-P supplying oxisol. This comparative study of P extraction methods indicated that use of

either oxalate-P or resin-P + bicarbonate-P pools of Hedley sequential fractionation scheme are better suited to determine soil P availability in oxisols that receive strategic applications of lower amounts of fertilizer P.

We evaluated the impact of intensive disc harrowing (2, 4 or 8 disc harrow passes per year over 3 years) on soil physical and chemical properties, soil P dynamics, plant growth, and nutrient acquisition of contrasting agropastoral systems on an Oxisol. Intensive disc harrowing improved macroporosity values for grass alone pasture system compared to native savanna. Intensive disc harrowing significantly improved volumetric moisture content of green manure and maize systems. The distribution of biologically, moderately and sparingly available P, organic P and total P varied under green manure, maize and grass alone pasture systems. Two passes of disc harrow per year were sufficient for grass alone pasture while maize showed greater aboveground production and nutrient acquisition at 8 passes of disc harrow per year. The maize and green manure cropping systems were better than the grass alone pasture system at separating the effect of increased number of disc harrow passes on soil physical and chemical characteristics.

In another field study we also evaluated the impact of strategies including chisel tillage (1, 2 or 3 passes), crop rotations (rice-soybean), and agropastoral systems (rice-grass alone pasture; rice-grass/legume pasture) on the buildup of an arable layer and on grain yields of upland rice and soybean. We assessed the build-up of an arable layer in terms of improved soil physical characteristics (bulk density, penetration resistance), soil nutrient availability, soil P pools, plant growth, and nutrient acquisition during the fourth year after the establishment of different treatments on native savanna soil. Results on grain yields of upland rice showed that three passes of chisel could have a negative effect on grain yield, and that the yield decline was greater in agropastoral treatments than in rice-soybean rotation. Results indicated that the use of chisel tillage and agropastoral treatments can contribute to the buildup of an arable layer in low fertility savanna soils of the Llanos of Colombia as indicated by improved soil physical properties and nutrient availability. However, to realize the yield gains due to build-up of arable layer, there is a need for developing better crop management strategies to control weeds. Integration of more intense production systems that build the 'arable layer' but thereafter revert to more conservative tillage practices may be viable alternatives whose sustainability should be examined at the landscape scale.

In addition to the field studies, several greenhouse studies were conducted to define the adaptive attributes of crop and pasture components to infertile acid soils. These studies indicated that forage legumes are more efficient in acquiring P per unit root length. Comparative studies of a forage grass (*Brachiaria dictyoneura* CIAT 6133) and a legume (*Arachis pintoi* CIAT 17434) demonstrated that the legume could acquire P from relatively less available P forms from oxisols of Colombia. This knowledge is useful to match the plant components to overcome edaphic constraints and to model plant responses to P supply in soil.

Crop simulation models are increasingly used to estimate crop yields as affected by nutrients and water inputs as well as management practices and climatic conditions. A group of models, CERES for cereal simulation growth and CROPGRO for legume simulation, have been used successfully around the world for various purposes. A computer model for the simulation of P in soil and plant relations has been developed and added to the two above crop simulation models to enhance their capabilities especially in tropical areas where P deficiencies are common. We tested these models using data on maize, soybeans and upland rice grown under acidic tropical conditions in the Colombian savannas. The sensitivity analysis done on the model showed that it is responsive to different rates of P fertilizer applications as well as to initial conditions of labile P. Several growth parameters responded to P additions. Some of the growth parameters that do not seem to be affected by P fertilization are: flowering and maturity dates, panicle number and leaf number. The

model still needs to be tested with P response experiments such as the Phosphorus Residual experiment from Matazul in the Llanos of Colombia.

We also tested NuMaSS (Nutrient Management Decision Support System) using the data from the field experiments in the Llanos of Colombia. Application of this decision support tool indicated that in the Llanos of Colombia upland rice production is considerably more profitable than either maize or cowpea given the yields obtained and the costs of fertilizer and the price of grain. As a result of this testing, buffer coefficients and critical levels of Bray-II P were subsequently included in PDSS2 (Phosphorus Decision Support System).

The main lessons learned from the work in tropical savannas can be summarized as follows: 1) P from fertilizers and P released from organic residues flows preferentially into labile inorganic pools, but much more slowly into more stable pools; 2) P flows rapidly through, and does not accumulate in, organic pools in the short-term; and 3) crop and forage cultivars differ in their ability to acquire and utilize P, and these differences can be exploited to improve P input use efficiency in crop-livestock systems of the tropics.

Andean Hillsides Agroecosystem - Cauca, Colombia

The volcanic-ash soils in Colombian hillsides generally contain high amounts of soil organic matter (SOM) but nutrient cycling through SOM in these soils is limited because most of it is chemically protected, which limit the rate of its decomposition. Short-term planted fallows on these P-fixing soils could restore soil fertility by enhancing nutrient recycling through the provision of soil organic matter (SOM). Field and greenhouse studies were conducted to assess the magnitude and timing of nutrient release and to establish relationships with chemical characteristics (quality) of 5 green manures and 4 organic materials as a means of defining selection criteria. Results indicated significant diversity in decomposition and nutrient release patterns and highlighted the value of screening new farming system components to achieve an efficient nutrient cycling and minimal environmental impact. Greenhouse studies on nitrogen mineralization and crop uptake from surface-applied leaves of green manure species indicated that green manures that decomposed and released N slowly resulted in high N uptake when they were used at pre-sowing in a tropical volcanic-ash soil.

Studies on the impact of improved fallows on soil fertility indicated that *Tithonia diversifolia* slash/mulch system has the greatest potential to improve soil fertility. Nevertheless, it may not be suitable to areas with seasonal drought as it is not very tolerant to extended dry periods. The *Calliandra calothyrsus* slash/mulch fallow system proved to be the most resilient as it produced similar amounts of biomass independent of initial level of soil fertility and was thus a candidate for wider testing as a potential source of nutrient additions to the soil and to generate fuelwood for resource-poor rural communities. The slower rates of decomposition in *C. calothyrsus*, compared to *Indigofera constricta* and *T. diversifolia* indicated that benefits provided may be longer lasting and potential losses would be reduced through improved synchronization between nutrient availability and crop demand for nutrients. The *I. constricta* slash/mulch fallow, on the other hand, was less adapted to low soil fertility and this may limit its potential for extended use.

The *T. diversifolia* slash/mulch fallow showed the greatest potential to improve SOM, nutrient availability, and P cycling because of its ability to accumulate high amounts of biomass and nutrients. The amount of P in the light (LL) and medium (LM) fractions of SOM correlated well with the amount of "readily available" P in the soil. It is suggested that the amount of P in the LL and LM fractions of SOM could serve as sensitive indicators of "readily available" and "readily mineralizable" soil-P pools, respectively, in P-fixing volcanic-ash soils. These results also indicated that fractionation of SOM and

soil P could be more effective for detecting the impact of planted fallows on improving soil fertility than the conventional soil analysis methods.

Field studies on root and shoot attributes of crop and forage components has identified elephant grass as an effective fodder grass for Andean hillsides which can minimize soil loss and also acquire greater amounts of N, P and K from low fertility acid soil due to its abundant fine root production. Studies on rooting strategies of naturalized and introduced pastures indicated that naturalized pasture is adapted to low soil fertility conditions due to its ability to produce a finer root system. Intercropping of cassava with cover legumes reduced soil loss and improved nutrient acquisition by cassava.

The main lessons learned from the work in Andean hillsides can be summarized as follows: 1) The *Tithonia* slash/mulch fallow system appear to be the best option to contribute to the rapid restoration of soil fertility; 2) *Tithonia* fallow system could also increase the plant available P pool in soil; and 3) *Calliandra* fallow system could improve soil fertility and also provide good quality firewood for cooking for resource-poor farmers.

Strategic P inputs are an essential component to increased and sustained agricultural production in low-P soils. Small strategic P applications based on soil P availability and reduced crop P requirements will gradually build up the level of available P in the soil. Consequently, the frequency and amounts of P applications required to sustain production will decrease with time. Combined with strategic P inputs, P-efficient germplasm will contribute to agricultural sustainability by: (i) reducing the need to improve soil P status to higher levels to achieve similar productivity, a strategy which is also more demanding regarding maintenance levels of P; and (ii) increasing the efficiency of use of the applied P, which is a nonrenewable resource. Moreover, P-efficient crops would bring the economic rates of applied P within reach of smallholder farmers who might otherwise not use fertilizers.

The effect of mixtures of legumes with contrasting quality on anaerobic N degradation and aerobic N release

*K. Tscherning*¹, *E. Barrios*², *M. Peters*³, *C. Lascano*³, *R. Schultze-Kraft*¹

¹University of Hohenheim, Germany, ²Tropical Soil Biology and Fertility Institute, Centro Internacional de Agricultura Tropical (CIAT). Cali, Colombia and ³Tropical Forages, Centro Internacional de Agricultura Tropical (CIAT). Cali, Colombia.

Two tropical shrub legumes with contrasting quality *Indigofera constricta* Rydb. (*Indigofera*, no tannin content), and *Calliandra* sp. nov. (*Calliandra*, high soluble tannin content), were selected. Freeze-dried plant material was ground to 1 mm and mixed in the following proportions (based on air dry matter basis): 100:0, 75:25, 50:50, 25:75, 0:100 (*Calliandra* : *Indigofera*). All samples were subjected to the following chemical analysis: N, C, P, NDF, ADF, IADF, lignin, soluble and bound condensed tannins (sCT and bCT) utilizing standard protocols. N release during aerobic and anaerobic degradation were measured.

The NDF, ADF, Lignin and IADF content of the tissue decreased linearly with increasing proportion of *Indigofera*. Soluble CT content decreased with increasing proportion of *Indigofera*, while N content and IVDMD increased with increasing proportion of *Indigofera* in the mixture.

In the aerobic system the extent of measured mineralized N was lower than estimated for the mixture Call50/Ind50. Stronger N immobilization was observed in the Call75/Ind25 than in Call100. Thus it seem, that mixing prunings of the two legumes altered N mineralization, at the expense of a reduced

total amount of mineralized N. In the long run, the remaining N as result of mixing legumes might contribute to the formation of humic and fulvic substances.

The strong immobilization of N found in Call75/Ind 25 relative to Call100 might be due to a rapid increase of microorganisms nourished by soluble and easily available C components provided from the 25% of *Indigofera*. This may have led to the incorporation of N by microorganisms, an effect known as short term N-lack. When the mixture consisted of more than 50% of the high-tannin legume *Calliandra*, the amount of sCT increased sharply in the mixture and reached the additive value. However, no short-term positive effects in N release were observed with any of the legume mixtures during the duration of this study.

Mixing the low quality legume *Calliandra* sp. with the high quality legume *Indigofera constricta* improved the extent of gas production (Call50/Ind50), *in-vitro* dry matter degradation and IVDMD (Call25/Ind75). On the other hand, measured degraded N was not different ($P>0.01$) from estimated N for Call50/Ind50 and Call25/Ind75. Thus no N loss occurred due to the CT complexation suggesting that a wide range of other tannin-binding compounds such as carbohydrates present in *Indigofera* may have spared proteins from binding with tannins. In the Call75/Ind25 mixture the sCT content were very high and as a consequences inhibited N degradation.

Soluble and bound condensed tannins did not show an additive behaviour in the 25Call/75Ind and 50Call/50Ind mixtures, which could explain some of the positive and negative effects on the aerobic and the anaerobic systems. For example in the 50Call/50Ind mixture, there was a positive interaction in the anaerobic system as indicated by higher amount of gas production than was estimated for the mixture. Thus it seems that the anaerobic system copes more effectively with the adverse effects on nutrient release or degradation of high sCT content. The high diversity of microorganisms in the rumen liquid may allow a quick adaptation to changing substrates due to the short residence time of the nutrients in the rumen. Degradation processes in the soil are more long term and composition of microorganisms may not change as quickly as in the rumen.

Evaluating soil quality in tropical agroecosystems of Colombia using NIRS

Elena Velasquez^{1,2}, *Patrick Lavelle*², *Edmundo Barrios*¹, *Richard Joffre*³, *France Reversat*²

¹ Tropical Soil Biology and Fertility Institute, Centro Internacional de Agricultura Tropical (CIAT), Cali, Colombia;

² Institut de Recherche pour le Développement (IRD), Bondy, France. and ³ Centre d'Ecologie Fonctionnelle et Evolutive, CNRS, Montpellier, France

Near infrared reflectance spectroscopy (NIRS) analysis was used to distinguish among soils of different agroecosystems in Colombia, based on differences in quality and quantity of organic matter and in certain chemical and biological properties. A correlation was sought between the wavelengths determined by NIRS and certain chemical properties of the soil (Ca, Mg, K, Al, total P, N-NO₃⁻, Bray II-P, N-NH₄⁺), the percentage of carbon content in different SOM fractions separated by physical methods (LUDOX), and microbial activity measured by respirometry in the laboratory. The variables evaluated were grouped into three classes: (i) chemical variables (Ca, Mg, K, exchangeable Al, total P, Bray-II P), (ii) organic variables (total C, total N, N-NH₄⁺, NO₃⁻, respirometry and soil organic matter fractionation) and (iii) NIRS variables (101 variables given by the absorptions in the near infrared region). For each group of variables, a PCA, together with discriminant analysis, was run. Each group of variables separated the different soil-use systems ($p < 0.001^{**}$) similarly. Afterwards, co-inertia analyses among the different groups of variables verified the sensitivity of the NIRS in detecting significant changes in the soil chemical and organic composition, as well as in microbial activity. These results show the high potential of the NIRS for evaluating soil quality in large areas,

rapidly, reliably and economically, thereby facilitating decision-making with respect to soil management and conservation.

Impact of soil fertility status on specific responses to N, P, and K inputs in Western Kenya

B Vanlauwe, J Mukalama, and C Gachengo
TSBF -CIAT

Soil fertility depletion may occur at different levels within a farm resulting in, often strong gradients in soil fertility status at the farm level. These differences in soil fertility status are likely to affect various processes underlying ISFM practices and need to take into consideration for optimizing the efficiency of resource use in terms of mineral and organic inputs and labour, provided the impact of these gradients on ISFM strategies is substantial.

A study was carried out to determine how responses to specific nutrients vary for soils with a different soil fertility status. Limiting nutrient strips were laid out in six farms in three sites in Western Kenya. These sites were Aludeka (Teso District), Emuhaya (Vihiga District), and Shinyalu (Kakamega District). The sites were selected on the basis of their differences in biophysical, socio-economic and ethno-cultural aspects. On each farm, trials were established on a field furthest away from the homestead ('bush' field), on a field near the homestead ('homestead' field) and on a field intermediate between both ('medium' field).

The limiting nutrient strips consisted of 5 treatments: one control, one plot with N (at 100 kg N/ha), P (100 kg P/ha), and K (100 kg K/ha) applied, one plot with P and K applied, one plot with N and K applied, and one plot with N and P applied. Each field contained one strip. Responses to individual nutrients were calculated as relative yields of the treatment with one nutrient missing over the completely fertilized treatment.

Total biomass (grain, cob, and stover) yields of the control plots were significantly higher in the 'homestead' fields than in the two other field types. (Fig. 5)

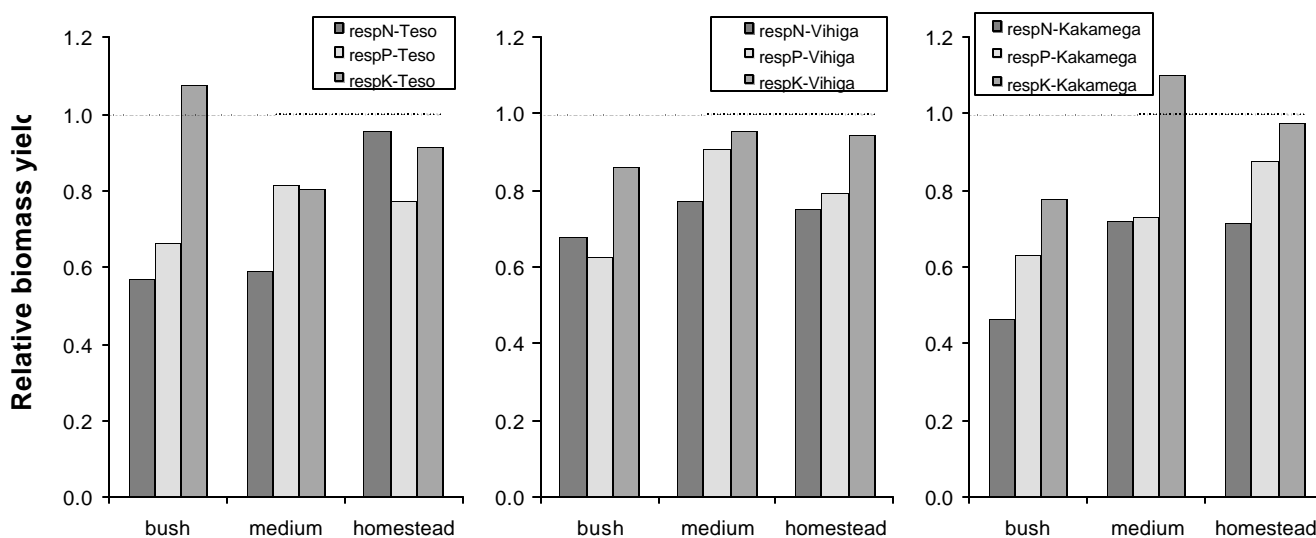

Figure 2: Relative total biomass yields in Teso (top), Vihiga (middle), and Kakamega (bottom) District. The dashed line corresponds to relative yields of 1 and consequently no response to the missing nutrient.

The preliminary evidence shown above points at the necessity to take site-specific nutrient limitations in consideration when devising recommendations for mineral input use. N and P were by far the most limiting nutrients, while K was only missing under specific conditions. Relative yields in absence of P and K were consistent across the various sites, indicating that the overall biophysical and socio-economic conditions had little influence on the specific soil fertility status within farms.

Impact of P source and application rate on immediate and residual maize yield on a Nitisol in Western Kenya

C Gachengo and B Vanlauwe

TSBF-CIAT

In Western Kenya, soil P availability is a major limitation to crop production. Soils in this region are generally low in available P and have high P fixing capacity. Various interventions may be applied to address this problem. Options of P application strategies that lead to optimum utilization of applied P are desirable. The current experiment was set up to determine effect of P application rates and P residue effects on soil and maize yields.

The experiment was located at Nyabeda in Siaya district (Western Kenya) at 1420 m above sea level. The topsoil had a pH in water of 5.4 with 15.4 g kg⁻¹ organic C, 2.4 mg kg⁻¹ resin-P, 4.9 cmol_c kg⁻¹ exchangeable Ca, 1.2 cmol_c kg⁻¹ exchangeable acidity, 57.8% clay, 28.7% sand, and 13.5% silt

In a number of treatments, P was added as TSP only at the beginning of the first crop at different rates (0, 15, 30, 50, 100, 150 and 250 kg P ha⁻¹). A treatment with initial application of 250 kg P ha⁻¹ and seasonal additions of 30 kg P ha⁻¹ to maintain a reasonable yield through the study period was introduced. Maize was grown as a test crop.

Maize yields were taken for ten consecutive seasons (two seasons per year). Results show that grain yields decreased drastically after the 7th season for all treatments (Fig. 1). Except for the second season that gave a bad crop due to poor rainfall, all treatments sustained a more or less similar grain yield for the first seven consecutive crops.

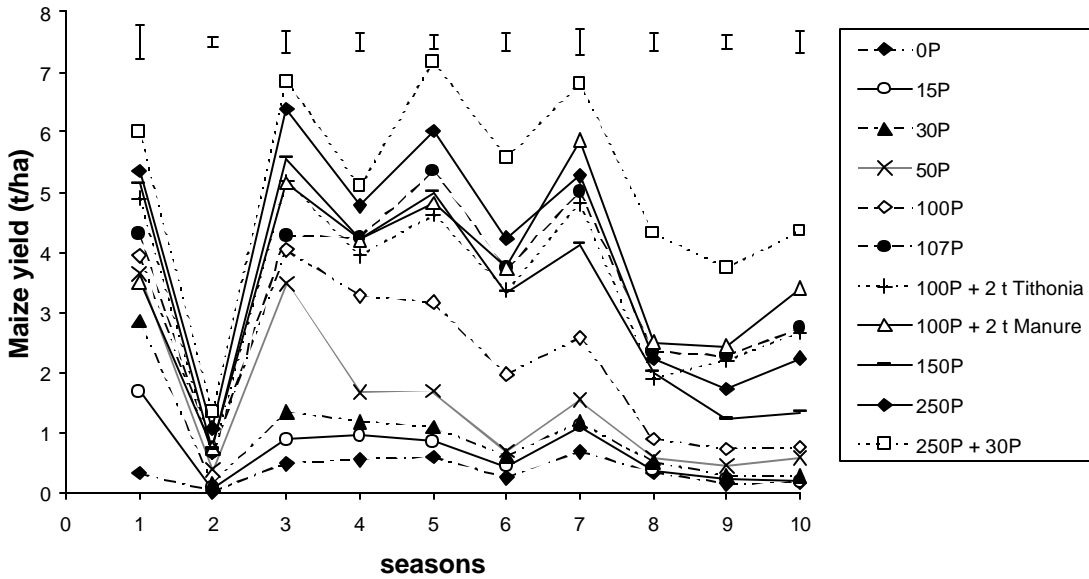

Figure 6: Maize grain yields at Nyabeda over a five-year period. Bars on the graph are Standard Errors of the Difference.

Maize grain yield increased with increased quantities of P applied resulting in curves that did not level out even at an application rate of 250 kg P ha⁻¹ (Fig. 7).

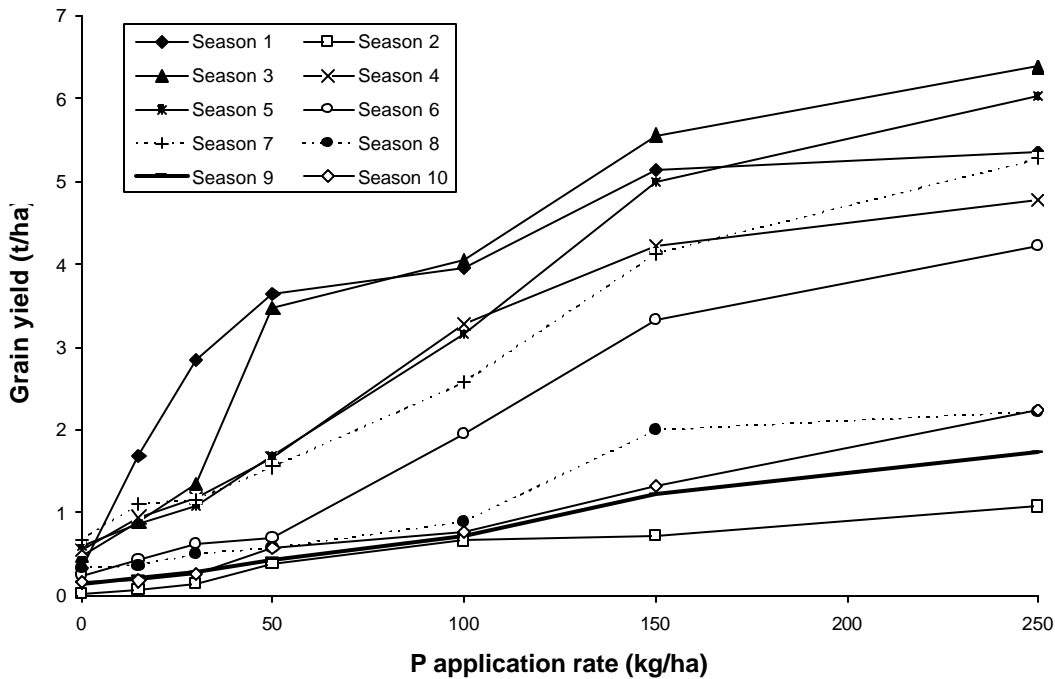

Figure. 7: Maize grain yield response to P application rates.

A single application of at least 150 kg P ha⁻¹ could sustain maize production significantly above the control (ANOVA results) through the ten seasons. Application of 15, 30 and 50 kg P ha⁻¹ sustained grained yield for one, four and six seasons respectively while 100 kg P ha⁻¹ sustained grain yield above the control treatment for at least the first seven seasons. *Tithonia*, cattle manure and TSP applied to supply P at a rate of 107 kg P ha⁻¹ performed equally well in terms of grain yield.

Network collaborative trials in East and Southern Africa and West Africa, 2002

André Bationo and AfNET collaborators

TSBF-CIAT, Nairobi, Kenya

Several network on-station, on-farm researcher managed and farmer-managed trials were established at representative benchmark sites in some important agro-ecological zones of Southern, East and Western Africa as shown in Figure 8.

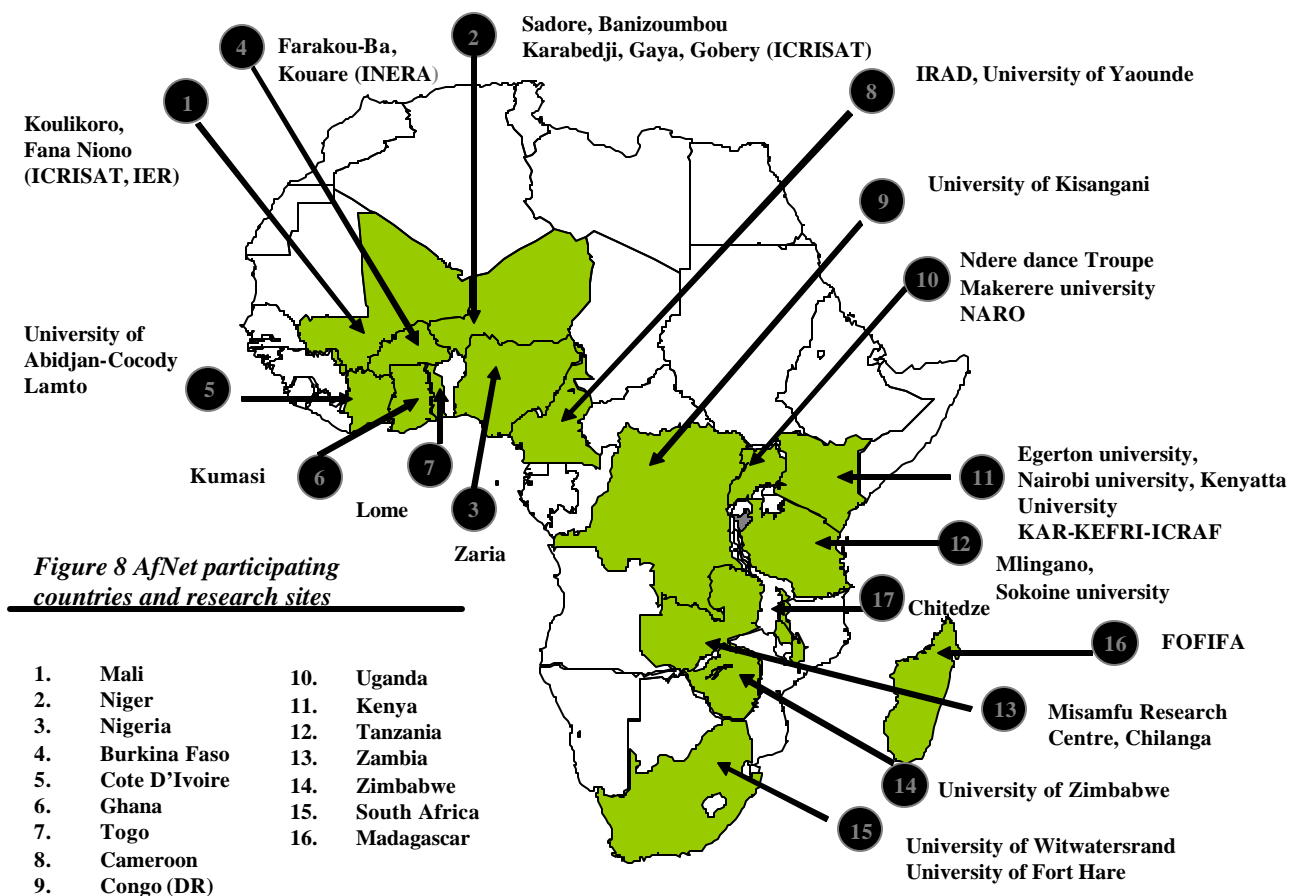

Long-term management of phosphorus, nitrogen, crop residue, soil tillage and crop rotation in the Sahel

Since 1986 a long-term soil fertility management was established by ICRISAT Sahelian Center to study the sustainability of pearl millet based cropping systems in relation to management of N, P, and crop residue, rotation of cereal with cowpea and soil tillage. The traditional farmers' practices yields 146 kg/ha of pearl millet grain whereas with application of 13 kg P/ha, 30 kg N/ha and crop residue in pearl millet following cowpea yielded 1866 kg/ha of pearl millet grain. These results clearly indicate the high potential to increase the staple pearl millet yields in the very poor Sahelian soils.

Maintenance of soil fertility under continuous cropping in maize-bean rotation

The Kabete long-term trial was started by KARI at the National Agricultural Laboratories site, on a humic Nitisol in 1976. The objective of the trial was to find appropriate methods for maintaining and improving the productivity of soil through the use of inorganic N and P fertilizers, farmyard manures and crop residues under maize-bean rotation practices that are common to small-scale farmers. In 2001, samples were collected from key treatments to study P dynamics and to examine the effects of the different treatments on P pools and P availability.

Long-term management of manure, crop residues and fertilizers in different cropping systems

Since 1993 a factorial experiment was initiated at the research station of ICRISAT Sahelian Center at Sadore, Niger. The first factor was three levels of fertilizers (0, 4.4 kg P + 15 kg N/ha, 13kg P + 45 kg N/ha), the second factor was crop residue applied at (300, 900 and 2700 kg/ha) and the third factor was manure applied at (300, 900 and 2700 kg/ha). The cropping systems are continuous pearl millet, pearl millet in rotation with cowpea and pearl millet in association with cowpea. The analysis of variance data indicate that fertilizer; crop residue and manure application resulted in a highly significant effect of both pearl millet grain and total dry matter yields. Fertilizer alone account for 34% in the total variation of the dry matter whereas manure account for 18%. Although some interactions are significant they account for less than 3% in the total variation.

Optimum combination of organic and inorganic sources of nutrients

In 2002 and 2003, network experiments were conducted at 7 benchmark locations across 7 countries to investigate the nitrogen and phosphorus contribution of different low quality organic materials that are available for direct use by farmers.

Site 1: Banizoumbou, Karabedji ;Niger

Interaction of N, P and manure.

A factorial experiment of manure (0, 2 and 4 t/ha), nitrogen (0, 30 and 60 kg N/ha) and phosphorus (0, 6.5 and 13 kg P/ha) was established in Banizoumbou to assess the fertilizer equivalency of manure for N and P. The data show a very significant effect of N, P and manure on pearl millet yield. Whereas P alone accounted for 60% of the total variation, nitrogen accounted for less than 5% in the total variation indicating that P is the most limiting factors at this site. Manure account for 8% in the total variation.

Experiments conducted at Banizoumbou and Karabedji sites in Niger showed that combination of both organic from cowpea and inorganic P sources achieved more yield as compared to inorganic sources alone. Application of P at 12 kg P ha⁻¹ resulted in cowpea fodder yields of 3,156 Kg ha⁻¹ whereas the same quantity of P applied with $\frac{3}{4}$ from manure and $\frac{1}{4}$ from inorganic sources resulted

in cowpea fodder yield of 4625 Kg ha⁻¹. The data from long-term soil fertility management experiment conducted at Sadore in Niger also supported the need combine organic and inorganic plant nutrient for sustainable pearl millet production in the Sahel. The addition of crop residue resulted in a significant increase in pearl millet yield

Site 2: Maseno, Western Kenya.

An integrated nutrient management experiment at Maseno was established in the highlands of Western Kenya on a nitisol at an elevation of 1420 m ASL and receiving an annual rainfall of about 1800mm distributed over two growing seasons. Farmyard manure (quality parameters) was used as the low quality organic resource and was integrated with 0, 30, 60 and 90 kg N ha⁻¹. Since this was a poor season, the overall grain yield and subsequent response to N was poor. However at 0-30 N levels, treatments integrated with organics consistently yielded higher than urea-N. These differences declined beyond 30N. In contrast, these manures appeared to be effective in overcoming P deficiency that is widespread on farms in Western Kenya.

At Maseno in Western Kenya, response to N application was slightly seen when P fertilizer was applied in season one only. Regardless of the increasing application of nitrogen, there was no response when no P was added. When P was added in season two only there was a slight decline in maize grain yield with the addition of N up to 60 kg N/ ha then a slight increase which could not justify the application of such huge quantity of N.

From these results it could be deduced that the most limiting nutrient at this site is P. However, when no N is added P addition in season two only had a more significant effect than when applied in season one only.

The use of Pueraria as the previous crop was found to significantly increase maize grain yield with or without the addition of N. More than 5 tons of maize grain yield was realised with the addition of P at either season compared to about 3 tons of maize grain yields obtained when no P was added.

Site 3: Kogoni, Mali

The experiment was conducted in collaboration with the Institut d' Economic Rurale (IER), Mali at the research station in Niono. The site was located at Kogoni in the rice-growing region. Low quality manures derived from livestock fed predominantly rice residues were used in combination with urea-N at 0, 30, 60, 90 and 120kg ha⁻¹. The data show rice yield response to N in the presence or absence these manures. Application of 90-120 kg N gave the highest paddy yield (approx 7.5 t ha⁻¹) thereby doubling yield over the control. Integration with manure did not significantly increase the rice yields at any N levels; rather there was a slight additive effect of applying the low quality material.

Site 4: Farakou Ba, Kou Valley, Burkina Faso

In Burkina Faso, trials were conducted at the Kou valley research station in collaboration with the INERA. The low quality organic input was manure (<1.0%N). The test crop was irrigated rice. The manure applied at 1, 2, 3 and 4 tons dry matter per hectare was combined with urea-N at 0, 40, 80 and 120 Kg N ha⁻¹. The data show rice yield response to urea-N alone or in combination with organic matter at 4 levels. Applications of N alone doubled rice grain yield over the unfertilized control. There was an additive increase when organic matter was integrated with inorganic-N at all manure levels, however this increase was not significant.

Site 5: Zaria, Nigeria

The experiments at Zaria are conducted in collaboration with Ahmadou Bello University. The site is located adjacent to the Danayamaka village to the North of Zaria within the Guinean zone.

These results show that in a maize-maize rotation, maximum P effect is observed when the application is made in the previous season than during the current cropping season. The addition of P during the first season increased yields by about 1 ton as compared to when P was applied during the second season. There was no specific effect on the maize grain yield when P was applied in both seasons (one and two). The data also show that in the experimental site, P is the most limiting factor and not N. When using herbaceous legume-maize rotation, the treatment involving application of P in the current crop resulted in the highest yield. Without addition of P in either season, a grain legume-cereal rotation system could achieve higher yields. However, with addition of P in either the first or second season a herbaceous legume-cereal rotation system is superior.

Activity 1.3. Integration of adapted germplasm with ISFM systems for increased impact on agricultural productivity and soil quality.

On-Going Work

Screening of dual-purpose soybean varieties for nodulation, biomass, and grain production under East African conditions

B Vanlauwe and J Mukalama
TSBF-CIAT

In response to rapidly declining soil fertility and resultant low crop yields in sub-Saharan Africa, IITA breeders in the early 1990s focused on developing improved varieties that fix a high proportion of their nitrogen from the atmosphere without inoculation (promiscuous soybean varieties) and produce large amounts of biomass. These 'new' varieties are often referred to as dual-purpose varieties as they do not only provide grains and/or cash but also leave a net amount of N in the soil from which subsequent cereals can benefit. The objectives of this work were to assess a range of best-bet dual purpose soybean varieties in terms of nodulation, biomass production, and grain yield under Western Kenyan conditions.

Four screening sites were chosen under on-farm conditions in Emuhaya (Vihiga District) during the short rainy season of 2001 and in Nyabeda (Siaya District) during the long rainy season of 2002. A set of 20 best-bet dual-purpose soybean varieties were obtained through IITA and planted in each of the above sites, treated or not with TSP at 30 kg / ha. Each site contained 2 replicates. A local variety, X-baraton, was included in all trials.

In both sites, most of the dual-purpose varieties out-performed the local variety in terms of nodulation (Fig. 9). Interestingly, variety 20, TGX-1448-2E, which is being used intensively in Nigeria, also belongs to the best performers under Western Kenyan conditions. In Emuhaya, 9 dual-purpose varieties produced more grains relative to the local variety while in Nyabeda, grain yield was rather similar for all dual purpose varieties as the control, except for variety 11 which produced less grains (Fig. 10). In Emuhaya, 4 dual-purpose varieties produced more total biomass at harvest than the local variety, while in Vihiga, 9 varieties outperformed the local variety (Fig. 11).

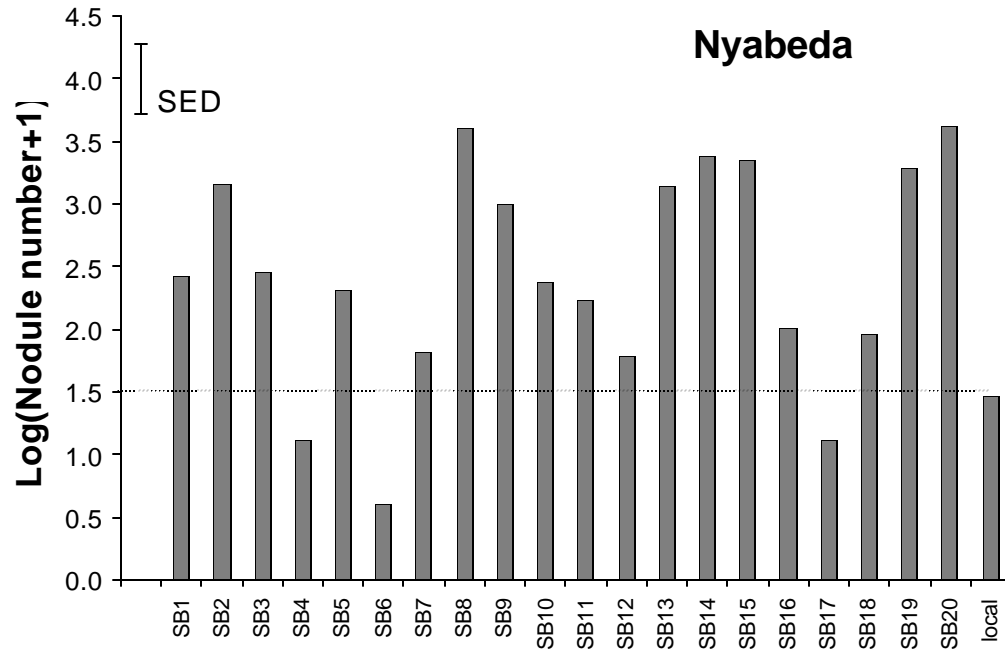
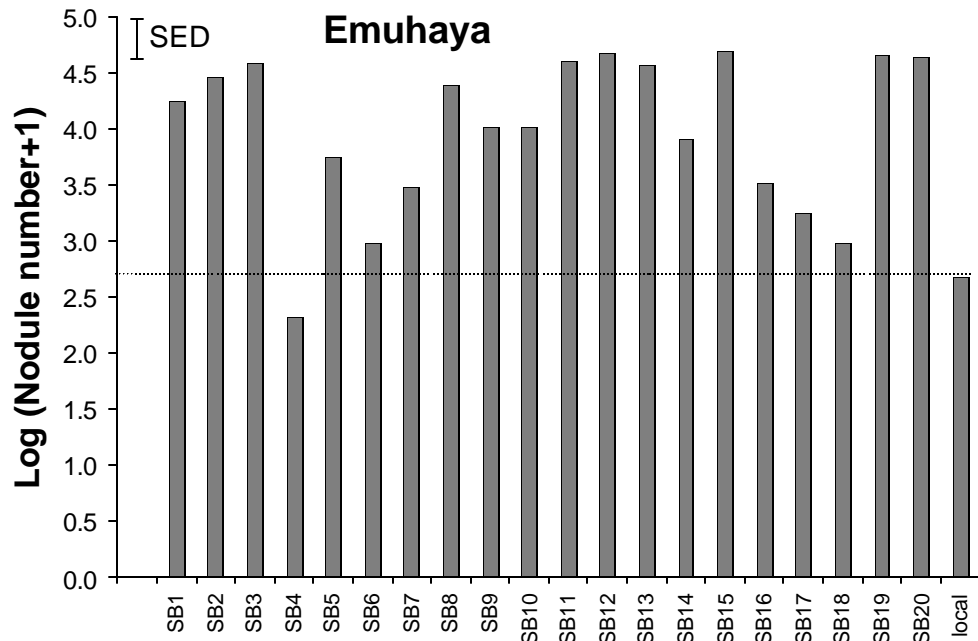

Figure 9: Nodulation of the various soybean varieties tested in Emuhaya (2001) and Nyabeda (2002). The local variety is X-baraton.

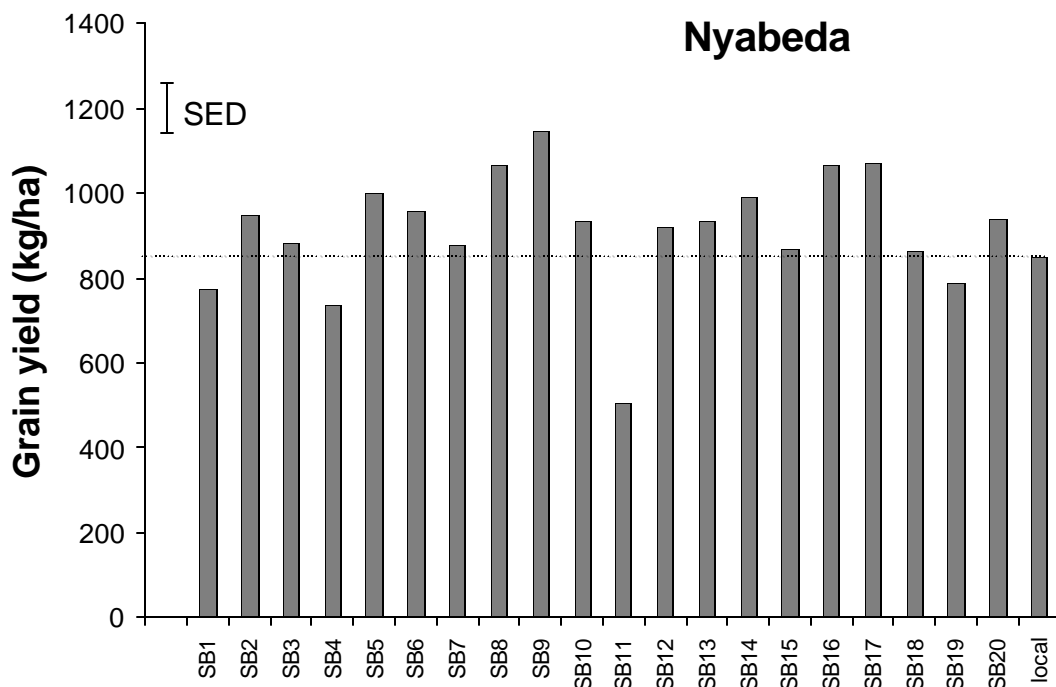
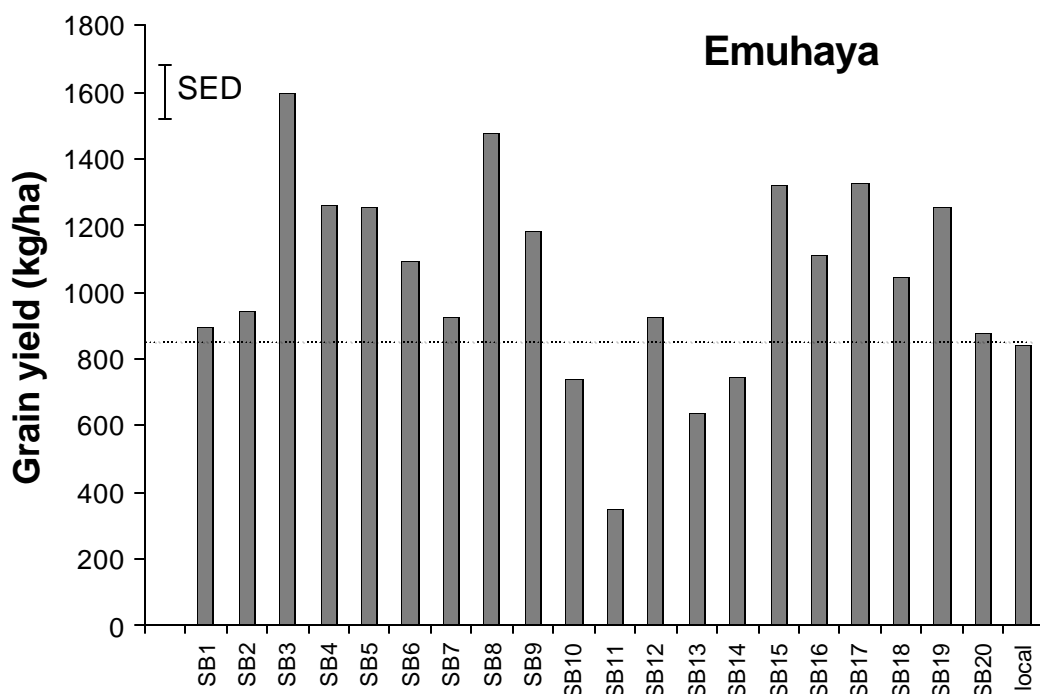

Fig. 10: Grain yield of the various soybean varieties tested in Emuhaya (2001) and Nyabeda (2002). The local variety is X-baraton.

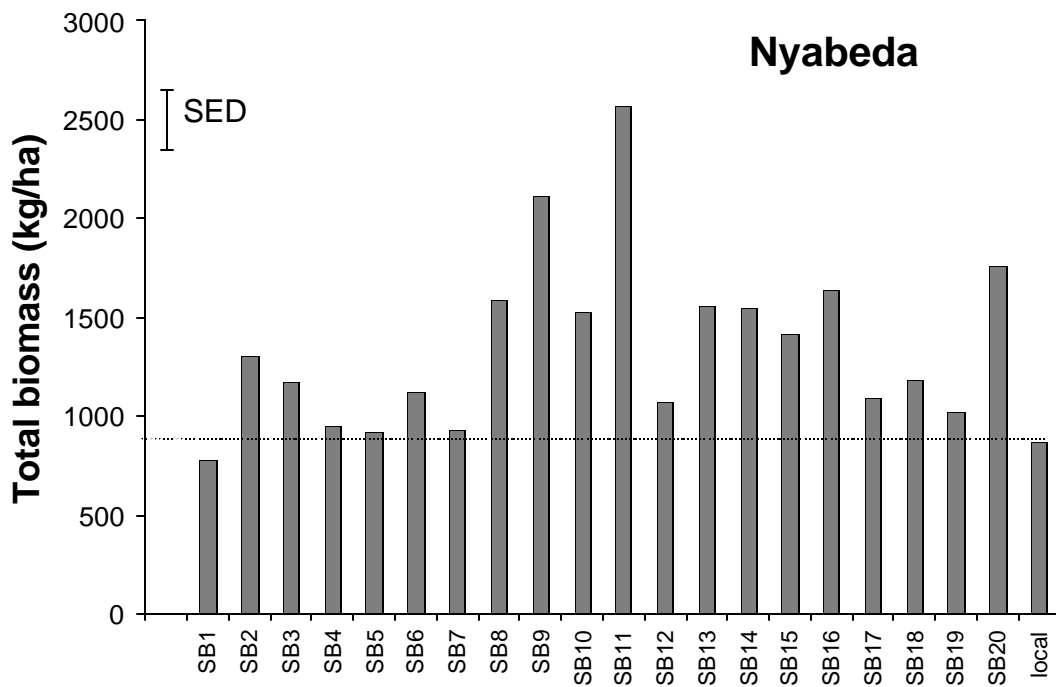
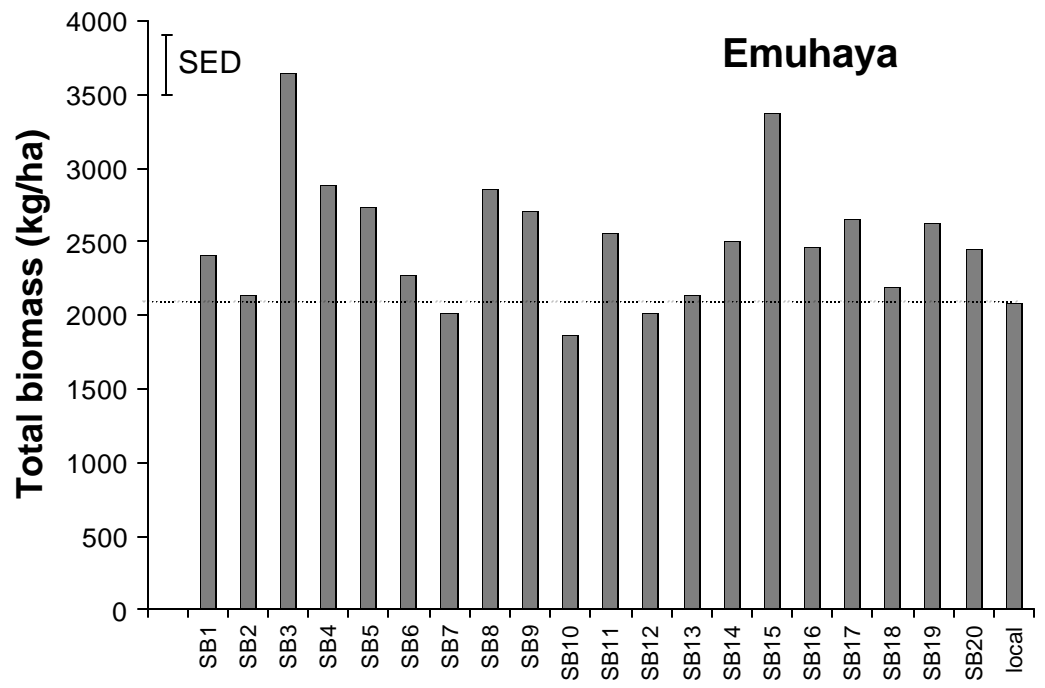

Fig. 11: Total biomass production of the various soybean varieties tested at harvest in Emuhaya (2001) and at 50% podding in Nyabeda (2002). The local variety is X-baraton.

Promiscuity of most of the tested varieties is retained under Western Kenyan conditions, although the dual-purpose varieties were not specifically bred for these environments. In Nyabeda, more biomass was produced by almost half of the varieties while grain yield was maintained, pointing in the direction of a higher or less negative N balance after the soybean crop. In Vihiga, varieties that produced more biomass also produced more grain, which may not enhance the net input in the soil relative to the local variety. However, the higher nodule numbers on the dual-purpose varieties may indicate a higher proportion of N fixed and consequently a more positive N balance. Obviously, the net N input in the soil needs to be confirmed through N analysis and assessment of the amount of biologically fixed N.

Evaluation of cowpea and Lablab dual-purpose legumes

R. Delve and P. Nyende

TSBF-CIAT, PO Box 6247, Kampala, Uganda

The criteria used for legume cover crop (LCC) species selection and the farmers' innovations with these LCC species in the participatory action research of INSPIRE in Tororo district revealed new constraints and opportunities of the farming system. Farmers' assessment of the LCCs revealed many positive and negative aspects for each species, but of major concern was on *Mucuna* and *Canavalia* which were disliked because their seeds are not edible yet they looked very attractive to eat, and are produced in large numbers, even in dry seasons. Despite the strong caution not to eat the seeds, a few farmers attempted to cook and eat seeds from these LCC seeds. A research agenda that address this new challenge of proving dual-purpose legumes was introduced in 2002. Two species cowpea and lablab were evaluated as dual-purpose legumes to address farmers' prioritized need for food, fodder and soil fertility improvement

Fifteen elite lines of cowpea identified and developed by the Grain Improvement Program of IITA, Nigeria, were introduced with two main objectives of the trials:

1. To evaluate the performance and farmer evaluations of these lines in view of selecting the most promising as regards to improving soil fertility and provision of food and fodder.
2. To provide grain legumes improvement programs with regional evaluation data and to select lines for further testing

Fifteen cowpea lines (including a local check) were tested on-station at the Distinct Agricultural Training and Information Centre in Tororo, eastern Uganda. Crop management, trial layout and data collection was strictly followed based on recommendations from the Grain Improvement Program of the IITA. In addition, a farmer evaluation of the varieties was also done at grain harvesting stage with the objective of evaluating the varieties for acceptability and seed multiplication. This was done on a farmer field day organized in collaboration with Africa 2000 Network and the DATIC management. In a participatory manner, 20 farmers from each of the two sub counties of Kisoko and Osukuru participated in an absolute evaluation of the 15 varieties.

Before a field a valuation farmers were engaged in a discussion on several aspects of the cowpea crop. Farmers revealed that they grow only one variety of cowpea, locally known as 'Ngori'. This has either white or brown seeds. The following were listed as main ways in which the crop is utilized:

- ?? Leaves (at 3-4 WAP) are boiled and eaten as sauce (vegetable) with other foods
- ?? Seeds are roasted and eaten as snack e.g. with tea
- ?? Seeds are boiled and made into samosas using baking flour
- ?? A meal composed of cowpea serves as a food reserve during travels and is eaten while travelling as keeps long in the stomach
- ?? Cowpea is used in exchange for labour if there is no cash available at hand

?? Cowpea is also known to improve soil fertility

Cowpea is mainly planted during the short rain season because it does not tolerate too much rain. Farmers traditionally broadcast cowpea and ensure larger spacing compared to that recommended by the Grain Improvement Program of IITA (20cm x 50cm). Leaves are picked at 2-3 weeks after planting and used as vegetables. Also at this time thinning is done and leaves and/or whole stems are used in sauce preparation. Pruning encourages more branches to sprout and more flowers to develop and hence more yields. Young and tender leaves are continuously picked during the entire growing period for sauce. In Tororo, there are several grain legume food crops grown but the major ones in order of importance are cowpea, groundnuts, common bean, simsim, soyabean and green gram. Cowpea was ranked first because it fetches more income than other grains grown in the area.

Farmers' criteria used to evaluate the cowpea varieties

The following criteria was consensually agreed upon and enlisted by the farmers and used to conduct an absolute evaluation:

- ?? Multiple utilization (e.g. as vegetable sauce, Sumbusa)
- ?? Pest and disease tolerance
- ?? Improve soil fertility
- ?? Good taste and satisfaction obtained when eaten (i.e. ability to stay in the stomach for long)
- ?? Grain yield obtained (i.e. many grain filled pods)
- ?? Marketability of the grain seed (i.e. big seed, uniform colour)

This present season the farmers are further evaluating the five most promising varieties. In addition, two more varieties bred by Makerere University are being evaluated alongside these. Evaluations will be done at two stages, at 2-3 WAP (for vegetable attributes) and at harvest maturity for grain and biomass yield.

The evaluation was done by men and women separately to cater for gender differences.(Table 5)

Table 5. Men's ranking of cowpea lines

Farmer ranking	Replicate No.			
	REP 1	REP 2	REP 3	REP 4
1	IT95K-238-3	IT98K-205-8	Local check	IT95K-238-3
2	Local check	IT95K-238-3	IT98K-205-8	Local check
3	IT94K-437-1	IT97K-499-38	IT94K-437-1	IT98K-205-8
4	IT98K-279-3	IT94K-437-1	IT95K-238-3	1T98-279-3
5	IT98K-205-8	Local check	1T98D-1399	IT98K-1382
6	IT98K-1382	IT97K-350-4-1	IT98K-279-3	IT98K-1382
7	IT95K-463-6	IT98K-463-6	IT98K-1312	IT97K-499-34
8	IT97K-350-4-1	IT97K-1068-7	IT97K-566-6	IT98K-131-2
9	IT97K-1068-7	IT97K-449-38	IT97K-350-4-1	IT97-556-4
10	IT97K-499-38	IT97K-350-4-1	IT94K-440-3	IT97K-1068-7
11	IT97K-499-39	IT98K-131-2	IT97-499-8	IT94K-440-3
12	IT94K-440-3	IT97K-1069-7	IT94K-440-3	IT98K-463-6
13	IT98K-131-2	IT94K-440-3	IT94K-437-1	IT94K-440-3
14	IT97K-556-4	IT98K-1382	IT98K-463-6	IT97K-350-4-1
15	IT98D-1399	IT98D-1399	IT98K-1382	IT98D-1399

Table 6. Men's ranking of cowpea lines

Farmer ranking	Replicate No.			
	REP1	REP 2	REP 3	REP 4
1	Local check	IT98K-205-8	Local check	Local check
2	IT98K-205-8	IT97K-499-38	IT95K-238-3	IT95K-238-3
3	IT98K-279-3	IT94K-437-1	IT94K-437-1	IT98K-205-8
4	IT98D-1399	IT95K-238-3	IT98K-279-3	IT98K-278-3
5	IT97K-1068-7	Local check	IT98K-205-8	IT97K-1068-7
6	IT95K-238-3-3	IT94K-440-3	IT98K-1382	IT97K-279-3
7	IT97K-499-38	IT97K-350-4-1	IT97K 350-4-1	IT98K 1382
8	IT94K-437-1	IT97K-556-4	IT98D-1399	IT97K 556-4
9	IT94K-446-3	IT98K-279-3	IT97K-1068-7	IT97K-350-4-1
10		IT97-1068-7	IT97K-1068-7	IT98D-1399
11	IT97K-350-4-1	IT97K-499-39	IT97K-499-39	IT97K-499-39
12	IT98K-1382	IT98K-463-6	IT97K-556-4	IT94K-437-1
13	IT97K-499-39	IT98K-1382	IT94K-440-3	IT98K-131-2
14	IT97K-556-4	IT98K-131-2	IT98K-131-2	IT94K-440-3
15	IT98K-463-6	IT98D-1399	IT98K-463-6	IT98K-463-6

The central objective in conducting a genderized evaluation of the cowpea lines was to make proactive efforts to ensure that women participate and benefit from the technology and capture their innovations. It was anticipated that women face different constraints from men and have different incentives to invest in or adopt cow pea varieties. Based on the evaluation results and field observations, men gave higher score to the local variety compared to the women. However, with regard to the new varieties under evaluation, there wasn't much difference in preference between women and men as reflected also in the evaluation criteria. Furthermore, based on the criteria enlisted by the farmers, the following varieties look promising: IT98K-238-3-3, IT98K-279-3, IT98K-205-8, IT98K-279-3, IT95K-238-3.

Mineral nitrogen contribution of *Crotalaria grahamiana* and *Mucuna pruriens* short-term fallows in eastern Uganda

Tumuhairwe, J.B¹, B. Jama², and R. Delve³, M.C. Rwakaikara-Silver¹

¹Makerere University, Department of Soil Science, Kampala, Uganda²International Centre for Research in Agroforestry, Nairobi, Kenya.³Tropical Soil Biology and Fertility (TSBF) and International Centre for Tropical Agriculture, Kampala, Uganda

African Crop Science Journal (submitted)

Nitrogen (N) is one of the major limiting nutrients to crop production in Uganda and is depleted at faster rates that replaced. Consequently, yields at farm level are less than 30% of the expected potential. Paradoxically, the majority subsistence farmers are poor to afford use of mineral fertilisers but improved fallow have been reported economically feasible in such conditions. Therefore, a study was initiated in Tororo district, eastern Uganda (i) to determine mineral N contribution of *C. grahamiana* and *M. pruriens* short-duration fallows compared with farmers' practices of natural fallow, compost manuring and continuous cropping, (ii) sampling period that closely related to maize grain yield was also determined and also (iii) whether improved fallow provided adequate mineral N for optimum grain yield compared to farmers' practices. It was noted that improved fallows increased mineral N at Dina's site during fallowing (at 0 week sampling), and in the first and fifth week after incorporating their biomass than farmers' practices. For instance, at harvesting fallows (0 week sampling), *C. grahamiana* and *M. pruriens* had 12.68 and 12.97 mg Kg⁻¹ N compared to 6.79 and 7.79 mg kg⁻¹ N from following natural fallow and continuous cropping respectively. However, no significant increase was realised at Geoffrey's site at any of the sampling dates attributed to low

biomass yield and incorporated. *C. grahamiana* increased grain yield by 29.3% (Dina's site) and 56.6% (Geoffrey's site) and *M. pruriens* by 36.0% (Dina's site) and 27.2% (Geoffrey's site) compared to natural fallow with -11.9% (Dina's site) and 17.4% (Geoffrey's site) then compost manure -9.6% (Dina's site) and 0% (Geoffrey's site) in relation to continuous cropping as a bench mark. Supplementing the land use systems LUS (*C. grahamiana*, *M. pruriens*, natural fallows, compost manure and continuous cropping) with inorganic N fertiliser as urea significantly increased grain yield in all except *C. grahamiana* at both sites. There were two peaks on mineral N. The first and major peak occurred in the third week dominated by NO_3^- -N and the minor one in the tenth week with NH_4^+ -N prominent consistent at both sites. Mineral N in the fifth week after incorporating biomass was most closely related to grain yield followed by sampling at planting (0 week).

The effect of green manures, *Mucuna*, *Lablab*, *Canavalia* and *Crotalaria* on soil fertility and productivity in Tororo District, Uganda.

Matthew Kuule and R. Delve

Makerere University, Kampala, Uganda and TSBF-CIAT, Kampala Uganda.

There is much concern over the declining crop yields over much of sub-Saharan Africa, and has largely been blamed on declining soil fertility, since increasing population has rendered traditional shifting cultivation and long-term fallowing, less practical. Strategies such as mineral fertilizer application, use of manure (compost and animal) and green manuring have been shown to sustain and/or increase soil productivity. Mineral fertilizers restore lost or limited soil nutrients fast, but are expensive for most farmers and do not improve soil organic matter. Similarly, compost and animal manure use is limited by the quality of the composted and/or feed material as well as the labour requirements for their preparation and application to farm fields. Legume cover crops, which are produced on the field with the crops and later incorporated into the soil to provide plant nutrients upon decomposition, could be a viable option for soil productivity improvement, especially in smallholder low-input agriculture systems. Whereas the technology has been widely adopted in the tropics, it is still low in Uganda, probably due to lack of awareness and performance data. This study was therefore planned to demonstrate the value of legume cover crops on soil productivity improvement and to determine and compare the economic viability of four legume species (*Mucuna pruriens*, *Crotalaria grahamiana*, *Lablab purpureus* and *Canavalia ensiformis*) in order to give sound recommendation for wider adoption of the technology. To be of relevance to farmers, six on-farm trials (each farmer as a replicate) were set up in two sub-counties Kisoko and Osukuru, and another on-station trial at the District Agricultural Training Centre (DATIC) with four replicates, in Tororo District, eastern Uganda. In August 2000, maize (cv. Longe1) was established on five-5 x 5 m plots and at first weeding stage (4WAP), the four legume cover species were each planted between maize rows in all the plots except the control (maize monocrop). After harvesting maize in December 2000, the cover crops continued to accumulate biomass for two more months, and in February 2001, the above ground biomass of the cover crops and of weeds was harvested, fresh weight taken, sampled for drymatter determination and incorporated into the soil during land preparation for the long rain season in March 2001. Production costs that were different for different treatments were estimated and recorded during the experiment. Maize yields were also recorded to allow computation of the returns from legume cover crops using marginal rate of return of non dominated treatments, as a basis for recommending the cover crop species to farmers. Results indicated significant ($p < 0.05$) maize yield increases for *Crotalaria* and *Lablab* treatment of 96.4% and 69.6 % respectively on farmers' fields in the second season (after legume biomass incorporation) and non-significant yield response to all legume cover crops on-station in both seasons, were obtained. The significant maize yield response to *Crotalaria* and *Lablab* on-farm and not on-station was probably due better synchrony of nutrients released from their biomass on an initially poorer soil at the on-farm compared the relatively better soil on-station. The analysis of costs and benefits revealed favourable marginal

rates of return to *Crotalaria*, *Canavalia* and *Mucuna* of 246, 120 and 30.4% respectively and were all recommended for adoption with more emphasis on *Crotalaria*.

Activity 1.4. Innovations for managing erosion and soil biophysical conditions / constraints.

Published work

Constructing an arable layer through chisel tillage and agropastoral systems in tropical savanna soils of the Llanos of Colombia

S. Phiri^{1, 2, 3}, E. Amézquita², I.M. Rao², and B.R. Singh¹

¹Agricultural University of Norway, P.O. Box 5028, NLH, N1432 Aas, Norway; ²Centro Internacional de Agricultura Tropical (CIAT), Apartado Aéreo 6713, Cali, Colombia; ³Misamfu Regional Research Centre, Kasama, Zambia

Journal of Sustainable Agriculture (In Press)

Integration of crop and livestock systems (agropastoralism) is a key strategy for intensifying agricultural production on infertile acid savanna soils, and for reversing problems of soil degradation in the tropics. The main objective of this study was to evaluate the impact of strategies including vertical tillage (1, 2 or 3 passes of chisel), crop rotations (rice-soybean), and agropastoral systems (rice-grass alone pasture; rice-grass/legume pasture) on the build-up of an arable layer and on grain yields of upland rice and soybean. We assessed the build-up of an arable layer in terms of improved soil physical characteristics (bulk density, penetration resistance), soil nutrient availability, soil phosphorus (P) pools, plant growth, and nutrient acquisition during the fourth year after the establishment of different treatments on native savanna soil. The soil used in this study was an Oxisol in the eastern plains (Llanos orientales) of Colombia. Agropastoral treatments (rice-grass alone pasture; rice-grass/legumes pasture) with vertical tillage decreased soil bulk density in the 0-20 cm soil layer by 12% when compared with the unmanaged native savanna. Consistent with bulk density, penetration resistance was also markedly decreased for 0-20 cm depth. Three passes of chisel (rice-soybean rotation) and pasture treatments (grass alone and grass/legume) improved the availability of Bray (II) P, K, Ca, and Mg in the 0-5 cm layer. The biologically available resin-P_i and NaHCO₃-P_i each represented 5% of the total P and were significantly affected by chisel down to 10-20 cm depth. The moderately resistant NaOH-P represented, on average, 33% of total P in the 0-20 cm soil layer, and both NaOH-P_i and NaOH-P_o were significantly affected by chisel tillage. Results on grain yields of upland rice showed that three passes of chisel could have a negative effect on grain yield, and that yields which declined over time declined more in agropastoral treatments than in rice-soybean rotation. These results indicate that the use of vertical tillage and agropastoral treatments can contribute to the build-up of an arable layer in low fertility savanna soils of the Llanos of Colombia as indicated by improved soil physical properties and nutrient availability. However, to take advantage of the constructed arable layer to improve crop yields, there is a need for developing better crop management strategies to control weeds.

Use of deep-rooted tropical pastures to build-up an arable layer through improved soil properties of an Oxisol in the Eastern Plains (Llanos Orientales) of Colombia

E. Amézquita¹, R.J. Thomas², I.M. Rao¹, D.L. Molina¹ and P. Hoyos^{1,11} Centro Internacional de Agricultura Tropical (CIAT), Cali, Colombia² ICARDA, Aleppo, Syria
Agriculture, Ecosystems & Environment (in press)

It is widely believed that tropical soils (mainly Oxisols) have excellent physical characteristics such as high infiltration rates, high permeability of water, good and stable soil structure and that consequently, they can support mechanized agriculture. However in the Eastern Plains (Llanos Orientales) of

Colombia, when Oxisols are subjected to tillage using disc harrow, soil physical conditions deteriorate rapidly. We report here that change in land use with deep-rooted tropical pastures can enhance soil quality by improving the size and stability of soil aggregates when compared with soils under monocropping. In addition, rates of water infiltration improved by 5 to 10-fold while rainfall acceptance capacity improved by 3 to 5-fold. We suggest that intensive and sustainable use of these Oxisols, could only be possible if an “arable” or “productive layer” (i.e. a layer with improved soil physical, chemical and biological properties) is constructed and maintained. One option to achieve this arable layer is through the use of introduced tropical pastures with deep rooting abilities that can result in increased soil organic matter and associated improvements in soil physical, chemical and biological properties. One land use option that can achieve these soil improvements is agropastoralism whereby pastures and crops are grown in short-term rotations.

This study shows that change in land use as introduced pastures can enhance soil quality by improving the size distribution of stable aggregates, water infiltration rates and rainfall acceptance capacity when compared with soils under monocropping. We suggest that the intensive and sustainable use of these soils, is only possible if an “arable” or “productive layer” is produced and maintained i.e. a layer with little physical, chemical and biological constraints. One option to achieve this arable layer is the use of introduced pastures with deep rooting abilities that can result in increased soil organic matter and associated improvements in soil physical and chemical properties. One land management option that can achieve these improvements is agropastoralism whereby pastures and crops are grown in short-term rotations.

Activity 1.5. Farming systems adapted to farmer circumstances are evaluated on farm.

Published work

Fallow management for soil fertility recovery in tropical Andean agroecosystems in Colombia
Edmundo Barrios, Juan G. Cobo, Idupulapati M. Rao, Richard J. Thomas, Edgar Amézquita, Juan J. Jiménez

*Centro Internacional de Agricultura Tropical (CIAT), A.A. 6713, Colombia
Agriculture, Ecosystems and Environment (in press)*

Andean hillsides dominate the landscape of a considerable proportion of Cauca Department in Colombia. The typical cropping cycle in the region includes monocrops or intercrops of maize (*Zea mays* L.), beans (*Phaseolus vulgaris* L.) and/or cassava (*Manihot esculenta* Crantz). Cassava is usually the last crop before local farmers leave plots to natural fallow until soil fertility is recovered and a new cropping phase can be initiated. Previous studies on land use in the Río Cabuyal watershed (6500 ha) show that a considerable proportion of land (about 25-30%) remains under natural fallow every year. The focus of our studies is on systems of accelerated regeneration of soil fertility, or improved fallow systems, as an alternative to the natural regeneration by the native flora. Fallow improvement studies were conducted on plots following cassava cultivation. The potential for soil fertility recovery after 12 and 28 months was evaluated with two fast growing trees, *Calliandra calothyrsus* Meissn (CAL) and *Indigofera constricta* L.(IND), and one shrub, *Tithonia diversifolia* (Hemsl.) Gray (TTH), as slash/mulch fallow systems compared to the natural fallow (NAT). All planted slash/mulch fallow systems produced greater biomass than the natural fallow. Greatest dry biomass (16.4 Mg ha⁻¹ yr⁻¹) was produced by TTH. Other planted fallows (CAL and IND) produced about 40% less biomass than TTH and the control (NAT) about 75% less. Nutrient levels in the biomass were especially high for TTH, followed by IND, CAL, and NAT. The impact of fallow management on soil chemical, physical and biological parameters related to residual soil fertility during the cropping phase was evaluated. Soil parameters most affected by slash/mulch fallow

systems included soil total N, available N (ammonium and nitrate), exchangeable cations (K, Ca, Mg and Al), amount of P in light fraction, soil bulk density and air permeability, and soil macrofauna diversity. Results from field studies suggest that the Tithonia slash/mulch fallow system could be the best option to regenerate soil fertility of degraded volcanic-ash soils of the Andean hillsides.

Sustainable intensification of crop livestock systems through manure management in Western and Eastern Africa: lessons learned and emerging research opportunities

Bationo, A.¹; Nandwa, S.M.²; Kinyangi, J.M.¹; Bado, B.V.⁴; Lompo, F.⁵; Kimani, S.⁶; Kihanda, F.⁷ and S. Koala⁸

¹*Tropical Soil Biology and Fertility Programme, P.O. Box 30592, Nairobi, Kenya.* ²*Kenya Agricultural Research Institute, National Agricultural Research Laboratories, P O Box 14733, Nairobi, Kenya.* ⁴*INERA, , Burkina Faso.* ⁶*Kenya Agricultural Research Institute, National Agricultural Resarch Center (Muguga), , Kenya.* ⁷*Kenya Agricultural Res. Institute, Regional Research Centre (Embu), P.O. Box 27, Embu, Kenya.* ⁸*International Crop Research for the Semi-Arid Tropics, B. P. 12404 Niamey, Niger.*

In the mixed farming system that characterises the Semi-Arid zone of Eastern and Western Africa, low rural incomes, high cost of fertilizers, inappropriate public policies and infrastructural constraints prevent the widespread use of inorganic fertilizers. Under this situation and as population pressure increases and fallow cycles are shortened, organic sources of plant nutrients such as manure, crop residue and compost remain the principal sources of nutrients for soil fertility maintenance and crop production. Estimates of the nitrogen contribution from manure to the total N input budget suggest that up to 80 percent of N applied to crop is derived from manure in both the extensive and the intensive grazing systems.

In this paper, we first discuss the effect of manure on soil productivity and on ecosystem functions and services. This is followed by highlights of the management practices required to increase manure use efficiency before tracking the emerging new research opportunities in soil fertility management to enhance the crop-livestock integration. Although the application of manure alone produces a significant response, it cannot be proposed as an alternative to mineral fertilizers. In most cases the use of manure is part of an internal flow of nutrients within the farm and does not add nutrients from outside the farm. Furthermore quantities available are inadequate to meet nutrient demand on large areas. Research highlights have indicated that different management practices including time and methods of manure application, sources and method of application, and integrated nutrient management enhance its efficiency.

Research opportunities include ecosystem functions and services of manure use, the establishment of fertilizer equivalency of different manure sources, the assessment of the best ratios of organic and inorganic plant nutrient combinations, the crop livestock trade-offs to solve conflicting demands for feed and soil conservation and the use of legumes directly for soil fertility and for animal feed. The establishment of Decision Support Guides and assessment of the economic viability of manure-based technologies in farmers-focussed research is presented as a powerful management tool intended to maximize output while preserving the environment in the mixed farming system of the semi-arid zones.

Sustainable resource management coupled to resilient germplasm to provide new intensive cereal–grain legume–livestock systems in the dry savanna

N. Sanginga¹, K. Dashiell¹, J. Diels¹, B. Vanlauwe², O. Lyasse¹, R.J.Carsky¹, S. Tarawali¹, B. Asafo-Adjei¹, A. Menkir¹, S. Schulz¹, B.B. Singh¹, D. Chikoye¹, D. Keatinge¹, and O. Rodomiro¹

*¹International Institute of Tropical Agriculture (IITA), Nigeria, ²Tropical Soil Biology and Fertility Programme (TSBF), UNESCO-Gigiri, PO Box 30592, Nairobi, Kenya
Agriculture, Ecosystems and environment (In Press)*

Sustainable resource management is the critical agricultural research and development challenge in sub-Saharan Africa. The accumulated knowledge on soil management gathered over the last 10 years, combined with solid crop improvement and plant health research at farmers' level, has brought us to a stage where we can now address with confidence the intensification of cereal–grain legume - based cropping systems in the dry savanna of West Africa in a sustainable and environmentally positive manner. The entry point for solving the problems of natural resource base deterioration has been the availability to farmers of resilient and adoptable germplasm of both cereals and legumes. The major hypothesis has been that adapting improved germplasm to soil problems will lead to resilient and sustainable cropping systems and be a starting point for the transformation of smallholder farmers earning 1\$ a day into medium or commercial farmers with incomes above 10\$ a day.

In recent years we have developed and implemented sustainable: (i) maize– promiscuous soybean rotations that combine high nitrogen fixation and the ability to kill large numbers of *S. hermonthica* seeds in the soil, and (ii) millet and dual-purpose cowpea that greatly enhance the productivity and sustainability of integrated livestock systems. The two systems are effectively used for the replenishment of soil nutrients and organic matter. In addition, the legume varieties have the traits that are most appreciated by farmers, such as high yields of grain and fodder that provide them with income. Economic analysis of these systems shows already an increase of 50–70% in the gross incomes of adopting farmers compared to those still following the current practices, mainly continuous maize cultivation. Furthermore, increases in legume areas of 10% in Nigeria (about 30,000 ha in the northern Guinea savanna,) and increases of 20% in yield have translated into additional fixed nitrogen valued annually at 44 million \$. This reflects at the same time an equivalent increase in land-use productivity and with further spread of the improved crops there are excellent prospects for additional economic and environmental benefits from a very large recommendation domain across West Africa.

Improvement of the cropping systems in the dry savanna has been driven by the adoption of promiscuously nodulating soybean varieties (in particular TGx 1448–2E) and dual-purpose cowpea in Nigeria. Adoption is very high, even in the absence of an efficient seed distribution system. The number of farmers cultivating the improved varieties increased by 228% during the last 3 years. Increased production of promiscuous soybean has been stimulated by increased demand from industries and home utilization. Production in Nigeria has been estimated at 405,000 t in 1999 compared to less than 60,000 t in 1984. A good proof of the positive results achieved is the fact that the NGO Sasakawa Global 2000 that is extensively involved in the introduction of new agricultural technologies has decided to introduce the package among farmers in northern Nigeria, Bénin, and Ghana. Most importantly these research results open new opportunities for the sustainable management of the soils in the savannas. Until now it has been generally accepted that currently in Africa it would be impossible to grow crops continuously on these soils without soil degradation or without the use of impractical or uneconomical quantities of inputs. It was considered that at all levels of farming there would still be a need for fallows. We are now at a stage where we are confident that continuous cropping with cereal – grain legume rotations can make agriculture much more attractive for the farmers in the dry savanna of West Africa. Indeed, it offers excellent opportunities for the

sustainable management of natural resources, while at the same time providing better income opportunities. Working on these new technologies with farmers in the benchmark areas has clearly shown the environmental and economic benefits to be derived from these new cropping systems.

We reject the common belief that intensive continuous cropping is not feasible in the moist savanna zone. On the basis of our accumulated research results we are now convinced that the future of sustainable agriculture in these zones lies in the use of intensified cropping systems, based on the rotation of N efficient and *Striga*-resistant cereals and dual-purpose grain legumes, combined with the optimum use of inorganic and organic inputs. For the farmers participating in the trials, the top priority is to produce enough food for the family and, preferably, a surplus to generate income as well. In parallel studies to investigate farmers' perceptions of impact they clearly indicated that soil fertility and structure were important considerations, as well as improving their ability to keep more livestock. They mentioned that including a legume, such as dual-purpose cowpea and promiscuous soybean, in the system improved the soil. Farmers' wives in Bichi and Kaya villages informed researchers in early 1999 that if there were even more improved cowpea in the system, their incomes would increase and they anticipated that one impact at village level would be the provision of more wells for clean drinking water. This last example gives an indication of the potential implications of the interactions of the productive and environmental dimensions on human well-being.

The big success that has been reported for the research and development activities related to soybean production, processing, marketing and utilization in Nigeria (the country with the highest population in sub-Saharan Africa) and more modest successes in Ghana and Côte d'Ivoire were possible because of a group of highly motivated people from many organizations in these countries. The participatory methods that were used that resulted in the development and adoption on improved varieties, home utilization techniques and small income-generating businesses resulted in the improved well-being of millions of people in both urban and rural areas. This information will encourage other countries in sub-Saharan Africa and donors to establish similar soybean projects.

One of the next challenges to be faced is the scaling up of the results and implications from study sites to the moist and dry savanna domain as a whole. The selection of the initial research locations has attempted to capture the broad diversity of systems within the dry savanna. Success under these different conditions should confirm the robustness of the approach. Therefore, it is to be expected that similar benefits can be obtained in other areas with comparable agroecologies, population density, and market access. The research paradigm can still be further perfected, but the indications from farmers and researchers alike are that it is a promising approach to addressing and improving real situations in which farmers, the resource managers, need to improve the productivity of their crops and livestock without detriment to the environment. At IITA we have just gone through an extensive exercise of preparing our new strategic plan for the next ten years. One of the major challenges in developing the plan was how to translate our cumulative knowledge for the benefit of the sustainable development of the farming systems in the complex and difficult conditions in the various agroecological zones of the humid and subhumid tropics of sub-Saharan Africa. Inspired by the results obtained in the dry savannas of West Africa, we have decided that we should further explore this paradigm of Best Bet approaches. Consequently we plan to establish agroecological zone teams in the savanna, the humid forest, and the mid-altitude zone to address more effectively improved agricultural production in a sustainable manner. We see the opportunities of making progress in a more rapid manner over the coming years with an increased sense of optimism. The value of working together has been clearly demonstrated by the fact that in the experiments described in this paper the whole has shown to be greater than the sum of the individual parts.

Cowpea rotation as a resource management technology in savanna cereal-based systems in West Africa

R. J. Carsky, Agronomist, IITA ; B. Vanlauwe, Soil Scientist, TSBF-CIAT

A synthesis of results from the savanna zone of West Africa suggests that cowpea rotation can be considered to be an effective resource management technology in cereal-based systems. Part of the N requirement of cereal crops can be satisfied by cowpea crop rotation. The characteristics to be encouraged to maximize this benefit are the amount of nitrogen derived from the atmosphere and the amount of N returned in the residues. In addition the data suggest that 1) minimum soil requirements of cowpea should be respected, 2) the cereal should be planted as soon as possible after cowpea, and 3) the maturity class of the cowpea variety should be as long as possible. Benefits of cowpea rotation are often higher than expected based on the N content of the cowpea crop. Reasons for this include substantial root biomass and N, substantial N-sparing by the legume, and other benefits such as reduction in *Striga hermonthica* pest and disease reduction, and P solubilization. Adoptability of cowpea is high. Dembele (2000) for example compares grain legume systems adoption in Mali to forage legumes. Oyewole et al (2000) presented reactions of farmers to mucuna when they already had a cowpea system. It appears from this synthesis that cowpea rotation should be considered as an important resource management technology. However, for this to function, systems should be designed that maximize the benefit of cowpea to the soil-plant system. This will influence choices of cowpea varieties, management of those varieties, and management of the subsequent cereal crop.

Soil Fertility Management and Cowpea Production in the Semi-Arid Tropics of West Africa

Bationo¹, A., B.R. Ntare², S. Tarawali³ and R. Tabo²

¹IFDC/ICRISAT BP 12404 Niamey, Niger; ²ICRISAT Bamako, BP 320 Bamako, Mali³ ILRI/IITA, PMB 5320 Ibadan, Nigeria

World Cowpea Conference IITA (in press)

Cowpea (*Vigna unguiculata* L. Walp) is an important grain legume in West Africa as it is a major source of dietary protein for the people. It is usually grown as an intercrop with the major cereals, namely millet and sorghum. Despite its importance, its yields are very low due to several constraints including poor soil, insect pests and drought. The soils in the Semi-Arid West Africa are inherently low in nitrogen and phosphorus. Soil, water and nutrients management practices are inadequate to sustain food production and to meet the food requirement of the fast growing population.

Research results show that proper management of organic amendments such as crop residues and manure, which are essential complement to mineral phosphorus fertilizers, can increase yields of cowpea and associated cereals more than three fold. Direct application of indigenous phosphate rocks can be an economical alternative to the use of imported more expensive soluble phosphorus fertilizers for cowpea production in semi-arid tropics of West Africa. The agronomic effectiveness of indigenous phosphate rock is about 50% as compared to the imported single super-phosphate. Furthermore when the unreactive phosphate rocks are partially acidulated at 50%, their agronomic effectiveness can increase to more than 70%..

Studies on cereal-cowpea rotation revealed that yields of cereals succeeding cowpea can, in some cases, double as compared to continuous monoculture. In an efficient soil fertility management, cowpea can fix up to 88 kg N/ha and this results in an increase of nitrogen-use efficiency on the succeeding cereal crop from 20% in the continuous cereal monoculture to 28% when cereals are in rotation with cowpea. Furthermore, the use of soil nitrogen increased from 39 kg N/ha in the continuous cereal monoculture system to 62 kg N/ha in the rotation systems.

The increase of cowpea productivity and component in the cropping systems in this region will improve nutrition of people, increase the feed quantity and quality for livestock, and contribute to soil fertility maintenance. This should contribute to reduction in poverty and environmental degradation.

Completed work

Soil fertility management and cowpea production in the semiarid tropics

Bationo, A., B.R. Ntare, S.A. Tarawali, and R. Tabo

Cowpea (*Vigna unguiculata* [L.] Walp.) is an important grain legume in the semiarid zone of West Africa as it is a major source of dietary protein for the people. It is usually grown as an intercrop with the major cereals, namely millet and sorghum. Despite its importance, its yields are very low due to several constraints including poor soil, insect pests, and drought. The soils in semiarid West Africa are inherently low in nitrogen and phosphorus. Soil, water, and nutrient management practices are inadequate to sustain food production and to meet the food requirements of the fast growing population. Research results show that proper management of organic amendments such as crop residues and manure, which are essential complements to mineral phosphorus fertilizers, can increase yields of cowpea and associated cereals more than three fold. Direct application of indigenous phosphate rocks can be an economical alternative to the use of imported, more expensive soluble phosphorus fertilizers for cowpea production in the region. The agronomic effectiveness of indigenous phosphate rock is about 50% compared to the imported single superphosphate. Furthermore, when the unreactive phosphate rocks are partially acidulated at 50%, their agronomic effectiveness can increase to more than 70%.

Studies on cereal–cowpea rotation revealed that yields of cereals succeeding cowpea could, in some cases, double compared to continuous cereal cultivation. With efficient soil fertility management, cowpea can fix up to 88 kg N/ha and this results in an increase of nitrogen use efficiency on the succeeding cereal crop from 20% in the continuous cereal monoculture to 28% when cereals are in rotation with cowpea. Furthermore, the use of soil nitrogen increased from 39 kg N/ha in the continuous cereal monoculture to 62 kg N/ha in the rotation systems. Future research needs to focus on understanding the factors affecting phosphorus uptake from different sources of natural rock phosphate. There is also a need to quantify the below-ground nitrogen fixed by different cowpea cultivars. The increase of cowpea productivity in the cropping systems in this region will improve the nutrition of people, increase the feed quantity and quality for livestock, and contribute to soil fertility maintenance. This should contribute to reduction in poverty and environmental degradation.

Pathways towards integration of legumes into the farming systems of east African highlands.

Tilahun Amede

TSBF-CIAT, AHI, Ethiopia

Food legumes remained to be important components of various farming systems of Eastern Africa, while the attempt to integrate fodder legumes and legume cover crops (LCCs) since 1930s became unsuccessful. Farmers remained reluctant to integrate fodder legumes and LCCs, despite recognising their benefits as soil fertility restorers and high value feeds, mainly due to community/farmer specific socio-economic factors. Farmers' participatory research was conducted in Ethiopian Highlands to understand the processes of integration of legumes of different use into mixed subsistent farming systems. Areka had an altitude of 1990 masl, and rainfall amount of 1300mm, which is characterised by poor access to resources, intensive cropping, land shortage and soil degradation. Firstly participatory evaluation was conducted on the agronomic performance and adaptability of eight legumes during the main and small growing seasons of 2000 and 2001. The treatments were Vetch, *Stylosanthes*, *Crotalaria*, *Mucuna*, *Canavalia*, *Tephrosia*, Field pea and

Common bean. Following the agronomic evaluation, the perception of farmers to legumes of different use, the socio-economic factors dictating choices and adoption, and potential niches for legume integration into the cropping systems were considered.

Dry matter production among legumes was significant regardless of the length of growing period. For short term fallows, 3 months or less, *Crotalaria* gave significantly higher biomass yield (4.2 t ha^{-1}) followed by Vetch and *Mucuna* (2 t ha^{-1}), while for medium-term fallow, 6 months, *Tephrosia* was best performing species (13.5 t ha^{-1}) followed by *Crotalaria* (8.5 t ha^{-1}). The selection criterion of farmers was far beyond biomass production. Farmers identified firm root system, early soil cover, biomass yield, decomposition rate, soil moisture conservation, drought resistance and feed value as important criteria. There was significant difference in soil moisture conservation among LCCs, and decreased in order of *Mucuna* (22.8%), Vetch (20.8 %), *Stylosanthus* (20.2 %), bare soil (17.1 %), *Crotalaria* (14 %), *Canavalia* (14 %) and *Tephrosia* (11.9 %), respectively. The overall sum of farmers' criteria showed that *Mucuna* followed by *Crotalaria* could be the most fitting species, but farmers finally decided for Vetch, the low yielder, due to its fast growth and high feed value because of their priority to livestock feed than soil fertility. The final decision of farmers for integrating a non-food legume into their temporal & spatial niches of the system depended on land productivity, farm size, land ownership, access to market and need for livestock feed. The potential adopters of LCCs and forage legumes were less than 7%, while 91% of the farmers integrated the new cultivars of the food legumes. After characterising the farming systems of other benchmark sites, those indicators were used for development of decision guides to be used for integration of legumes into multiple cropping systems of East African Highlands.

Implication of optimum land use for human nutrition on soil fertility management in Ethiopian Highlands

Tilahun Amede

Food shortage in Africa is predominantly taken as a function of limited access to food, but rarely recognized as imbalanced nutrition. Food nutritional quality could be improved through different practices such as application of fertilizers and soil amendments, selection of varieties with high micronutrient content, use of high nutrient value crops and genetic modification of plants to improve micronutrient supplies. However the application of these methods to address malnutrition depends upon the availability of technological and policy interventions, that are commonly beyond the accessibility of small-scale farmers. Dietary supplements are also rarely available to the rural poor. One option to minimize the risk of malnutrition is through reallocation of cropland in favor of crops with high content of the nutrient in deficit. Once the nutrient budget of these systems is quantified and the type of the nutrient in deficit or excess is identified, the nutritional balance could be improved by reallocation of cropland, and increasing the land area allocated to crops rich in requisite nutrients.

Modeling the cropping system, by considering the adaptability of the crop to the environment in question, could offer a better and faster opportunity to reverse malnutrition. Altering cropland allocation may have a significant implication on soil and water management, as the change in crop type and area would affect interception of rain by the vegetative cover (the erosivity power), which is named as the crop factor (C-factor) in the USLE (Universal Soil Loss Equation). A shift from cereal-dominated system to a perennial-dominated system may improve the C-factor, while the reverse may cause more erosion and land degradation. Therefore, altering crop allotment to improve human nutrition should take soil fertility, conservation and management into account.

An optimization model was employed to analyze the scenario of human nutrition and cropland allocation in Enset (*Enset ventricosum*)/root crop –based (Areka) or cereal-based (Ginchi) systems of Ethiopian highlands and its possible implication to soil fertility management. The type and amount of

nutrients produced in each system was analysed and a model was developed to analyse which cropping strategies that may improve the nutritional quality of the household using the existing resources.

Both production systems were in food deficit, in terms of quantity and quality, except for iron. Energy supply of resource-poor households in the enset/root crop-based system was only 75% of Recommended Daily Allowance (RDA), while resource-rich farmers covered their energy, protein, zinc, and thiamine demand. Extremely high deficiency was found in zinc, calcium, Vit A and Vit C, which was only 26.5, 34, 1.78 and 12 % of the RDA, respectively. The RDA could be satisfied if they expand the land area of enset, kale and beans by about 20, 10 and 40 %, respectively, at the expense of maize and sweet potato. The critical deficit of the cereal-based system was also calcium, Vit A, and Vit C, which was only 30, 2.5 and 2% of the RDA. In the cereal system, the RDA could be fully satisfied by reducing crop land allocated for barley by about 50% and expand the land area of faba beans, kale and enset. However, Ginchi farmers have better coping options than Areka farmers as they own more land and higher number of livestock that could be used as buffering assets.

Crop reallocation, considering human nutrition as a sole criteria, could affect land management in various ways. In the root crop-based system, a shift from the root-crop/cereal mix to more Enset/beans system improved the crop factor at farm level (farm erosivity index) by 42 %, indicating that soil erosion could be significantly minimized. The same applies for the cereal-based system where by farm erosivity index was improved by 45 % . This also has a very strong implication for soil fertility management, as the enset system is traditionally privileged to be very rich in organic matter content, nitrogen and phosphorus. Firstly, the system may demand an intensified soil fertility management because of the expansion of perennials. Traditionally, farmers divide their farm into three major categories, namely homestead, mid field and outfield based on the fertility status, type of soil fertility management and type of crops grown. In the homestead, where enset is traditionally grown, about 80% of the whole organic fertilizer is applied. Hence, it is the most fertile corner of the farm because of addition of manure, crop residues and household wastes. Farmers even export crop residues from the outfield to the enset field as the local wisdom considers it as a mulch-loving crop. The expansion of Enset at the expense of cereals may, therefore, improve the nutrient budget of the system by encouraging farmers to intensify soil fertility management options, such as composting, better manure management and fair distribution of resources across soil fertility gradients. It may have a strong effect on labor and availability of organic resources to fertilize the expanding enset fields. In this case farmers would be encouraged to practice better organic resource production and management. Secondly, a shift from root crop /cereal dominating system to an enset-dominating system may minimize erosion effects through improved vegetative cover, by reducing the erosivity power by about 45%.

Sustainability of Crop Rotation and Ley Pasture Systems on the Acid-Soil Savannas of South America

E. Amézquita¹, D.K. Frieser², M. Rivera¹, I.M. Rao¹, E. Barrios¹, J.J. Jiménez¹, T. Decaëns³ and R.J. Thomas⁴

¹Centro Internacional de Agricultura Tropical (CIAT), Colombia. ²IFDC-CIMMYT, Nairobi, Kenya ³Université de Rouen, France. ⁴ICARDA, Aleppo, Syria.

Intensification of agricultural production on the acid-soil savannas of south America (mainly Oxisols) is constrained by the lack of diversity in acid (aluminum) tolerant crop germplasm, poor soil fertility and high vulnerability to soil physical, chemical and biological degradation. The use of high levels of inputs and monocropping is thought to be unsustainable since it may result in deterioration of soil physical properties as well as escalation of pest and disease problems. Traditional grazing systems

on native savanna species have very low productivity. Improved legume-based pastures can actually improve the soil resource base but require investments in inputs for establishment, which are unattractive to graziers. Other alternatives include establishment of pastures in association with rice (agropastoral systems) as well as rotations with grain legumes or green manures. Systems such as these may attenuate or reverse the deleterious effects of monocultures while permitting intensified agricultural production. To monitor the sustainability of such systems, biophysical measures are required as 'predictors' of system performance and 'health'. In 1993, a long-term field experiment was established in Carimagua, Colombia, (4°36'N, 71°19'W).

This 5-year field study examined the effects of contrasting rice-based production systems on rice productivity and indicators of soil chemical/fertility, physical and biological health. Increased intensity of fertilizer inputs associated with increased system intensity generally resulted in commensurate increases in soil fertility under those systems. A previous report (Friesen et al, 1998) showed increasing levels of inorganic N in soil profiles to 1-m depth under rice monoculture < rice-cowpea < rice-GM, with significant and substantial leaching due primarily to legume residues in the latter two systems. The long-term consequences and externalities of improved N fertility in such systems cannot be discounted.

Soil physical characteristics were generally improved with increasing system intensity, probably due to the degraded nature of the soils under native savanna. Cultivation generally helped to create an 'arable layer' (Phiri et al, 2001) by incorporating immobile nutrients such as P to depth in this infertile Oxisol. However, these beneficial effects can only be considered short-term. Cultivation also resulted in declining levels of SOM, particularly in the LL-C fraction, which may have consequences on soil structure in the longer term.

Soil macrofauna were the most adversely affected by production systems. Cultivation caused drastic reductions in earthworm populations and biomass, more severely so with increasing intensity and frequency. Since soil macrofauna have direct beneficial effects on many soil characteristics that affect its long term productivity (such as nutrient cycling, soil structure, soil water dynamics, bulk density and root penetrability), managing systems in ways that minimize the impact on macrofaunal populations will be an essential consideration in the sustainable use of this agroecosystem. Within the context of the savannas, Jiménez et al. (2001) proposed a hypothetical conservative agricultural production system to preserve benefits of soil fauna which integrated: (i) native vegetation plots possibly used as extensive pastures and as a reserve of biodiversity; (ii) permanent pastures for livestock systems that allow the establishment of important native earthworm biomass; (c) agropastoral systems with annual crops managed in rotation with temporary pastures and located contiguously to permanent pastures to maximize migration of populations. Integration of more intense production systems which build the 'arable layer' but thereafter revert to more conservative tillage practices may be viable alternatives whose sustainability should be examined at the landscape scale.

Mucuna pruriens and Canavalia ensiformis legume cover crops: Sole crop productivity, nutrient balance, farmer evaluation and management implications

Delve¹, R.J. and Jama², B.

¹Tropical Soil Biology and Fertility Institute of International Centre for Tropical Agriculture, Kampala, Uganda²
International Centre for Research in Agroforestry, Nairobi, Kenya

The high costs of inorganic fertilizers in Uganda limits their use by resource-poor smallholder farmers. There is also little practical knowledge existing in Uganda about the management of herbaceous legume cover crops that often are promoted as low-cost alternatives. Therefore, the effects of a one season sole-crop fallow of *Mucuna pruriens* and *Canavalia ensiformis* legume cover crop on a following maize crop and topsoil N, P and K balances were assessed for 2 seasons in two locations, Osukuru (0° 39' N, 34° 11' E) and Kisoko (0° 43' N, 34° 06' E) of Eastern Uganda. During land preparation, 50 or 100% of the aboveground biomass of *Mucuna* and *Canavalia* was manually incorporated into the topsoil (0 to 15 cm depth) using a hand hoe.

Mucuna and *Canavalia* aboveground biomass production was not affected by the initial soil fertility of the sites and produced 6 t ha⁻¹ at Osukuru and 7 t ha⁻¹ at Kisoko. Incorporation of 50% or 100% of the *in-situ* aboveground biomass significantly increased maize grain by up to 118% and stover yields by up to 75% compared to farmer practice in the first season after incorporation in nearly all treatments. No significant increases in maize grain or stover yields were observed in the second season after application. No significant differences were also observed between 50% and 100% *in-situ* biomass incorporation on maize grain and stover yields, giving resource poor farmers the option of alternative uses for the additional 50% of the biomass, for example, biomass transfer to other parts of the farm, for compost making or for livestock feed. In the first season after incorporation of the legume cover crops, addition of 100% and 50% of the aboveground biomass resulted in a positive nutrient balance for N only. Additions of 100% of the aboveground biomass of either *Mucuna* or *Canavalia* were needed for a positive nutrient balance for K, whereas none of the treatments produced a positive balance for P, thus suggesting the need for inorganic P fertilizers additions in order to mitigate depletion in the long run. Farmers had multiple criteria for assessing the different species and used these to select the potential species that fitted within their production systems and production objectives.

The results show that the use of *Mucuna pruriens* and *Canavalia ensiformis* significantly increased the following maize yields in the first season ($P < 0.05$) and in the residual season ($P < 0.10$). Farmer evaluations of the technology highlighted some negative aspects of this technology, for example, it needs increased management by the farmer as well as increasing the labour input into the cropping system, in addition, many farmers do not have the opportunity to leave land fallow for one season to produce the LCC. This method of soil fertility improvement is just one of the many options available to farmers and the exact production system the farmer develops will depend on many other issues, for example, access to inorganic fertilizers, the need for firewood, livestock feed or grain legume production. Farmer evaluations identified research gaps with this technology that are now being investigated in further on-farm experimentation. LCC species, however, still remain a strategic opportunity for the many farmers that have no access to fertilizers or animal manures and who have available land.

Output 2: Improved agroecosystem health through management of below ground biodiversity (BGBD)

Output rationale

Soil organisms contribute a wide range of essential services to the sustainable function of all ecosystems, by acting as the primary driving agents of nutrient cycling; regulating the dynamics of soil organic matter, soil carbon sequestration and greenhouse gas emission; modifying soil physical structure and water regimes; enhancing the amount and efficiency of nutrient acquisition by the vegetation through mycorrhiza and nitrogen fixing bacteria; and influencing plant health through the interaction of pathogens and pests with their natural predators and parasites. These services are not only essential to the functioning of natural ecosystems but constitute an important resource for the sustainable management of agricultural ecosystems.

The soil organism community, including bacteria, fungi, protozoa and invertebrate animals, is extremely diverse. Despite its importance to ecosystem function the soil community has been almost totally ignored in considerations of biodiversity conservation and management even at the inventory level. Few data are available from tropical regions, where it is suspected that the highest levels of diversity may be found. Although the biological diversity of the community of organisms below-ground is probably higher in most cases than that above-ground, it has generally been ignored in surveys of ecosystem biodiversity. Documentation of BGBD, including the biological populations conserved and managed across the spectrum of agricultural intensification, is an essential component of the information required for assessment of environment-agriculture interactions, as is the evaluation of the impact of agricultural management on the resource base, particularly that of the soil.

Governments have typically encouraged land conversion and agricultural intensification in response to the demand for higher levels of food production under conditions of increasing population growth. The processes of land conversion and agricultural intensification are a significant cause of biodiversity loss, including that of BGBD, with consequent negative effects both on the environment and the sustainability of agricultural production. The lowering of the biological capacity of the ecosystem for self-regulation has led to further need for substitution of biological functions with agrochemical and energy inputs.

The assumption is often made that the consequent reduction in the diversity of the soil community, including cases of species extinction, may cause a catastrophic loss in function, reducing the ability of ecosystems to withstand periods of stress and leading to undesirable environmental effects. It remains a matter to be critically evaluated whether the maintenance of such diversity entails costs or benefits in terms of agricultural production and change in other ecosystem services. This requires investigations at both the farm and at the landscape scales. The conservation of agrobiodiversity and the associated BGBD is of particular interest because of the possibility of win-win situations where gains are achieved not only in biodiversity but also in agricultural production and resource conservation.

Sustainable and profitable management of agricultural biodiversity, including BGBD, is dependent on information about the current status, the value perceived by the various sectors of society, and the factors which drive change in one direction or other. Despite a policy and economic environment that does not acknowledge the importance of managing and conserving agrobiodiversity; farmers, rural communities, scientists, NGOs and the general public have become increasingly aware of the high environmental cost of many intensive high-input agricultural practices. Furthermore, it is now

accepted that loss in biodiversity (including BGBD) is one of the major factors leading to degradation of ecosystem services and loss of ecosystem resilience. Development of appropriate policy requires, in particular, reconciling the needs for meeting food-sufficiency by high levels of agricultural productivity with those for conserving biodiversity and environmental protection.

Almost universally, attempts at integrated and sustainable agricultural development are frustrated by lack of an information base that rigorously demonstrates the environmental implications, whether beneficial or detrimental, of agricultural development, and the benefits or otherwise to be gained from conservation and management of agrobiodiversity, including BGBD. Policy formulation for BGBD conservation and management for local, national and global benefits is dependent on the availability of this information, which enables rigorous evaluation of the costs and benefits of different trajectories of development and the reconciliation between them. One planned outcome of this output is to provide tools and services for easing the incorporation of information on agrobiodiversity and BGBD in particular into decision making at all scales.

Milestones

1. Internationally accepted standard methods for characterization and evaluation of below-ground biodiversity (BGBD), including a set of indicators of BGBD loss developed.
2. Development of a global information exchange network for BGBD.
3. Inventory and evaluation of BGBD in benchmark sites and development of a global information exchange network for BGBD.
4. Sustainable and replicable practices for BGBD conservation identified and implemented in pilot demonstration sites.
5. Recommendations of alternative land use practices, and advisory support system, for policies that will enhance the conservation of BGBD developed.

Activity 2.1 Improved understanding of the relationship between agricultural intensification and the abundance, diversity and function of tropical soil biota.

Published work

Quantitative evaluation of the soil aggregation potential by external hyphae of arbuscular mycorrhizae

J. T. Reyes^{1,2,3}, E. Barrios¹, M. Sánchez de Prager²

¹ Tropical Soil Biology and Fertility Institute, Centro Internacional de Agricultura Tropical (CIAT). Cali, Colombia.

² Universidad Nacional de Colombia, Palmira, Valle del Cauca; Colombia.

³ Universidad Nacional de Agricultura, Catacamas, Olancho, Honduras
Applied Soil Ecology

Fungal hyphae have been found to stabilize soil into aggregates by physical enmeshment of soil particles and polysaccharide production. A methodological tool was developed for quantitative assessment of the potential of arbuscular mycorrhizal (AM) fungi to form water stable macroaggregates of soil under greenhouse conditions. We used two tropical grasses, *Melinis minutiflora* (Mm) or *Brachiaria dyctioneura* CIAT 6133 (Bd), as hosts for the AM fungi *Entrophosphora colombiana*, *Glomus manihotis* and *Gigaspora margarita*. Treatments consisted of combinations of three factors: presence of a plant (Mm, Bd, without plant), soil pretreatment (disinfected, untreated) and AM fungi inoculation (with, without inoculation). Experimental units had two compartments (A and B) connected by a central opening lined with a 44 µm nylon mesh that only allowed fungal hyphae to pass through. Inoculated and un-inoculated host plants were grown in compartment A and the soil aggregation potential by AM fungi was measured in compartment B.

Longest hyphal length values (20.8 m g⁻¹ of soil) were found in not-disinfected soil planted with Mm and inoculated with AM fungi. The same treatment was associated with the highest amount of soil aggregates > 2 mm (29.1%) and also presented the highest water stable aggregation values (42.9%). Soil aggregates between 0.25-2 mm showed higher stability values (75.6 %) in disinfected soil planted with Bd and inoculated with AM fungi. In this experiment, AM fungal hyphae contributed significantly to water stable aggregate formation, which confirms their fundamental role as temporal binding agents in soil aggregation. This protocol holds promise in the evaluation of AM fungi following management treatments in field trials as well as in the evaluation of AM fungi core collections for their soil aggregation potential.

Completed work

A global assessment using PCR techniques of mycorrhizal fungal populations colonizing *Tithonia diversifolia*

R. A. Sharrock¹, F. L. Sinclair¹, C. Gliddon¹, I.M. Rao², E. Barrios², P.J. Mustonen³, P. Smithson⁴, D. L. Jones¹, D. L. Godbold¹

¹ University of Wales, Bangor, UK; ² Tropical Soil Biology and Fertility Institute, Centro Internacional de Agricultura Tropical (CIAT). Cali, Colombia; ³ CATIE, Costa Rica; ⁴ ICRAF, Nairobi, Kenya

In this study the extent and nature of symbiotic fungal colonisation in *Tithonia diversifolia*, within its global distribution, was investigated by visual and molecular means. Family-specific PCR primers were used to identify (to family level) the arbuscular mycorrhizal fungi colonising *Tithonia* roots in different countries and regions, in an attempt to assess whether the high nutrient accumulation in *Tithonia* is related to specific mycorrhizal fungi.

Root samples were collected from *Tithonia diversifolia* populations of more than 50 individuals in Costa Rica, Nicaragua, Honduras, Mexico, Colombia, Venezuela, Ecuador, Indonesia, the Philippines, Kenya and Rwanda. These areas cover the global distribution of *Tithonia diversifolia*. Endomycorrhizal colonisation was determined using the magnified intersection method after staining in trypan blue.

Tithonia diversifolia root samples were entirely endomycorrhizal; no evidence of ectomycorrhizal colonisation was found. Analysis of hyphal, arbuscular and vesicular colonisation was undertaken (Figure 1). The degree of vesicular colonisation was less than 5% in all samples (data not shown). The most abundant fungal structures present were hyphae, followed by arbuscules and vesicles (which were the least abundant fungal structures present in each case). Colonisation ranged from 0 to 80% (using a summed estimate of colonisation), with a mean value of 40%. No mycorrhizal colonisation was found in the samples collected from the Philippines, and one each of the Rwanda and Venezuela samples. The highest colonisation value of 80% was observed in samples taken from provenances Indonesia and Honduras.

Fungal identification to family level using the family-specific primers generates a single PCR product between 150 – 200 bp in length. The presence or absence of this band indicates the presence or absence respectively of a particular family of arbuscular mycorrhizal fungi. An example of a typical electrophoresis gel clearly showing this characteristic banding pattern is shown in Figure 12. All five Kenyan root samples from Malava tested positive for the family *Glomaceae*. Positive PCR results for the family *Glomaceae* were obtained in samples from Costa Rica, Nicaragua, Indonesia, Honduras, Mexico, Kenya and Rwanda. No PCR product bands were generated for the families *Gigasporaceae* and *Acaulosporaceae* using primers specific to these families, except in one Nicaraguan sample.

The PCR products generated were sequenced, aligned and compared with published sequences on a BLAST database (www.ncbi.nlm.nih.gov). Several high alignment scores were obtained. The alignment score reflects the degree of similarity between a query sequence and the sequence being compared. The samples could be separated into 4 groups. For 10 of the samples in group 1, the highest alignment scores were found with published sequences of 2 fungi, *Glomus intraradices* and *Glomus vesiculiferum*. Three other samples had the highest alignment scores with these fungi plus one or two additional species. In group 2, three of the samples (two from Nicaragua and one from Rwanda) showed the highest alignment with five species of *Glomus* different to group 1. The two samples from Kenya showed the highest alignment with the five *Glomus* species plus two *Acaulospora* species and one *Scutellospora* sp. The only sample testing positive with the VAACAU primer showed the highest alignment with one species, *Acaulospora laevis*.

Alignment of the sequenced PCR products generated using the fungal specific primers produced a tree in which the sequences cluster within four groups (Figure 13). One group (group 4) contained the sequence generated by the VAACAU primer, and the other 3 groups contained the sequences from samples from Kenya and Nicaragua (group 3), Mexico, Nicaragua and Rwanda (group 2), and a large group with samples from Costa Rica, Honduras, Indonesia, Kenya, Mexico, Nicaragua and Rwanda. The groups were supported by bootstrap values greater than 50. Within the groups high bootstrap values were also evident. A comparison of the species alignments in Table 3 and the tree in Figure 3 shows a good correspondence between the alignment groups and the cluster groups. In the cluster group 3, all four sequences were generated from samples corresponding to the alignment group 3. Eleven out of the 12 sequences found in cluster group 1 were found in alignment group 1.

Although *Tithonia diversifolia* is a woody shrub, only arbuscular mycorrhizal associations were found. The extent of arbuscular mycorrhizal colonisation in *Tithonia* was similar for most samples collected, and was at a similar level to numerous species. In this work family specific primers were used to attempt to estimate the range of mycorrhizal associations formed by *Tithonia diversifolia*. If the positive amplifications using three family specific primers are used as an indication of the presence of different genera of AM fungi, then *Tithonia diversifolia* is globally almost only colonised by *Glomus* species. Only in one sample was a positive reaction with the other two family specific primers shown. This result suggests an unusually high specificity for one family of AM fungi.

Advances in molecular techniques, in particular PCR and sequencing technologies, have led to a much greater understanding of the phylogenetic relationships between endomycorrhizal fungal species. In the past the 150 or so identified species have largely been classified according to the morphological properties of their spores. Molecular analysis has highlighted a complexity and diversity between fungi, which was previously hidden. This has led to modification and in some cases reorganisation of the endomycorrhizal classification system. The development of family/genus/species-specific PCR primers as a tool for fungal identification *in situ* is dependent on current understanding of endomycorrhizal phylogenetics.

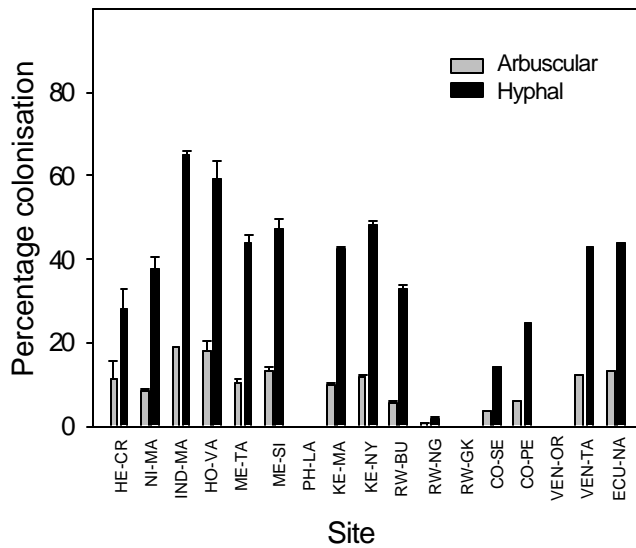

Figure 12. Mean fungal colonisation in *Tithonia diversifolia* root samples from Costa Rica (HE-CR), Nicaragua (NI-MA), Indonesia (IND-MA), Honduras (HO-VA), Mexico (ME-TA and ME-SI), the Philippines (PH-LA), Kenya (KE-MA and KE-NY), Rwanda (RW-BU, RW-NG and RW-GK), Colombia (CO-SE and CO-PE), Venezuela (VEN-OR and VEN-TA) and Ecuador (ECU-NA). Error bars represent standard error, n = 5 except for NI-MA, IND-MA, RW-GK which have n values of 6, 2 and 3 respectively. Samples CO-SE, CO-PE, VEN-OR, VEN-TA and ECU-NA all have an n value of 1.

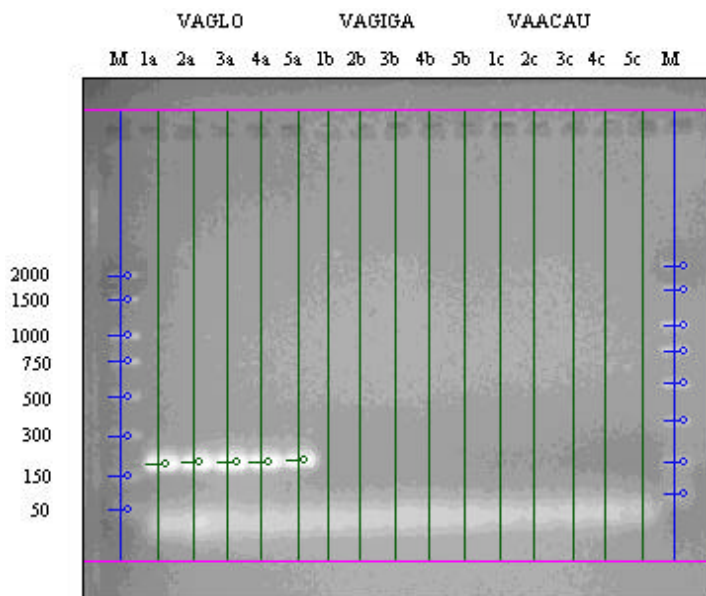

Figure 13. The identification of mycorrhizal fungi to family level using PCR with family-specific fungal primers in *Tithonia diversifolia* roots from Kenya, provenance KE-MA. M is the PCR ladder (bp), numbers 1 to 5 refer to the sample number, letters a, b and c indicates that primers VAGLO, VAGIGA and VAACAU were used respectively (in conjunction with primer VANS1). Primers VAGLO, VAGIGA and VAACAU target the fungal families *Glomaceae*,

Four groups of sequences were found in a neighbour-joining tree of AM fungi in roots of *Tithonia diversifolia*. With the exception of groups 3 and 4, these groups corresponded to four groups of species with the highest homologies using BLAST analysis. The species listed by the BLAST must be viewed with great caution. In the neighbour-joining tree, the branches within a group are often supported by high bootstrap values: this may be due to both different species with a group or more likely variation in the targeted region of the SSU rRNA gene. If it is assumed that this corresponds to variation in the target gene, and similarly assuming that the groups shown in the BLAST analysis are in reality only one or two species, then *Tithonia diversifolia* would appear to be colonised by only a few species of AM fungi throughout its range. However, a higher AM fungal diversity was shown in one sample from Nicaragua. The soils of all of the sites where *Tithonia* was collected will have experienced some degree of disturbance, but are not subject to annual ploughing. Thus, although it is unknown how quickly fungal biodiversity recovers from soil, it is unlikely that soil disturbance is the sole reason for the potentially low number of species colonising *Tithonia* roots.

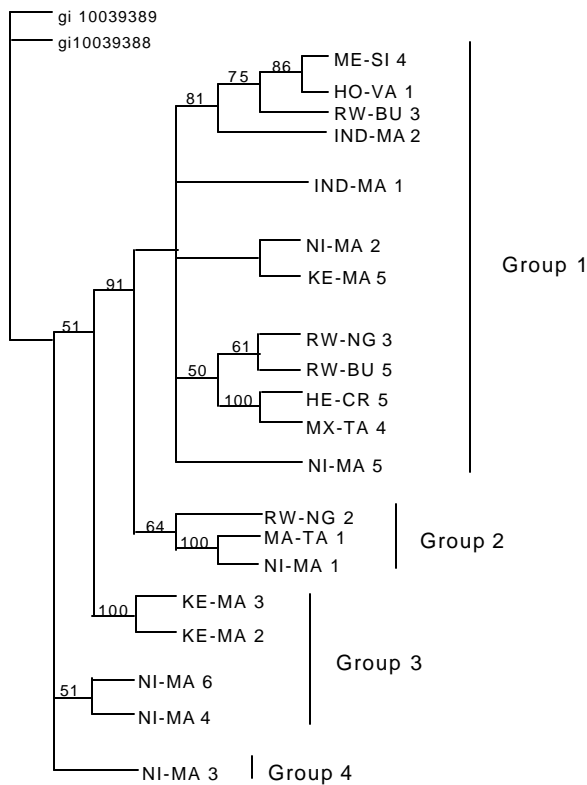

Figure 14. Neighbourhood joining tree of PRC products from roots of *Tithonia diversifolia*. Bootstrap values (%) of the neighbourhood joining analysis are shown above the branches (100 bootstraps). Only topologies with bootstrap support above 50% are shown.

Tithonia diversifolia is used as a green manure crop due to its reported ability to acquire high levels of P, particularly from infertile tropical soils. Arbuscular mycorrhizas have been shown to strongly facilitate P uptake. Arbuscular mycorrhizas are thought to act in functionally distinct groups, thus the apparent high specificity of *Tithonia diversifolia* may reflect host-symbiont compatibility to facilitate high P acquisition. However, clearly further work is required to support this suggestion.

On-Going Work

Standard Methods for assessing key functional groups of below-ground biodiversity

Jeroen Huising and Edmundo Barrios

This work calls for development of standard methods for the inventory of Below-ground biodiversity, associated ecosystem services and economic evaluation of both. For practical reasons we have separated the development of standard methods for inventory of BGBD and the economic evaluation of both BGBD and the associated ecosystem services, since these are separate activities that involve very different disciplines and consequently also different groups of experts. (work done on the economic valuation of BGBD is reported elsewhere)

At the Second Global BGBD Workshop (Sumberjaya, Indonesia, from February 24 to 28 2003) a lot of progress was made on the methods for inventory of macrofauna and for site characterization. In general the methods have been decided upon, leaving sometimes details on the protocols for sampling still to be resolved still. For each of the major functional groups of soil biota a person was named to be responsible for convening further discussion and finalizing the methods and protocols for sampling, including for those functional groups that were not extensively discussed in Indonesia, like methods for inventory of pests and pathogens and beneficial micro-organisms. The aim is to have all issues on methods resolved by September 2003.

A hands-on methodological workshop entitled “Application of Molecular Techniques in Soil Biodiversity Studies” was conducted at CIAT Headquarters in collaboration with Cornell University and USDA-ARS and took place between September 29 and October 3, 2003. The workshop focused on the T-RFLP (Terminal Restriction Fragments Length Polymorphism) method, developed by the Center for Microbial Ecology at Michigan State University, and widely used to assess differences in soil microbial communities as affected by different land uses. It covered aspects from soil sampling and DNA extraction and analysis to interpretation of results using multivariate statistical analyses. We had participants from Brazil, Colombia, Honduras, Indonesia, Ivory Coast, Kenya, Mexico, Uganda and USA and this included most WG1 country representatives of the BGBD project.

Standard methods for site characterization to be adopted for the inventory of the BGBD project benchmark areas

Jeroen Huising

At the Lampung workshop sampling strategy was discussed and decided upon. Sampling will be done according to sampling frames (or sampling windows) that will encompass the relevant land use systems in the benchmark areas. In most countries the sampling windows have been defined, and where needed some adaptation to the sampling approach has been made. Clarification on the sampling strategy and definition of the sample windows was also one of the objectives of the visits of the project coordinator to the various countries. Field visits by the coordinator were carried out in Kenya, Uganda, Mexico and Brazil.

List of the site characteristics that need to be recorded in the field has also been decided upon at the Lampung BGBD workshop.

Activity 2.3. Development of an integrated approach to ISFM and Integrated Pest and Disease Management (IPSFM).

Activity 2.4 Development of cross-scale practices for management of soil biota-mediated agroecosystem services.

Activity 2.5 Impact on policies on intellectual property rights of BGBD achieved.

Initiate investigation on international conventions and regulations regarding IPR with respect to BGBD

Jeroen Huising

In relation to the above it was decided to also investigate international conventions that deal with IPR and Biodiversity. This work will be contracted out and will probably be initiated next year.

Awareness raising is part of the activities covered under the milestones mentioned in the beginning of this chapter: "Recommendations of alternative land use practices, and advisory support system, for policies that will enhance the conservation of BGBD developed". The local and national press has covered the 2nd global workshop held in Indonesia. Also in other countries, such as Brazil, the project has received attention from the media, sometimes in connection to the national planning workshops. In some countries, such as Kenya the official launch of the project still needs to be done. One of the aims of having an official launch is to raise public awareness. The official launch of the project in the various countries will take place before actual start of the field work.

Further the BGBD project has actively sought to liaise with other initiatives, both at the global and national level. At the international level linking the project with the Millennium Ecosystem Assessment will be further explored, as well as linkage to the Alternatives to Slash and Burn Programme. In Brazil, for example the association between the BGBD project and the Large Biosphere Atmosphere programme has been discussed and will be further investigated. In Mexico collaboration with the UNDP/GEF funded programme "Manejo Integrado de Ecosistemas en tres Ecoregiones Prioritarias" has been sought as far as Los Tuxtlas is concerned (Los Tuxtlas is the BGBD benchmark area and one of the three priority eco-regions of the mentioned GEF project). Sometimes the liaison is established through personal linkages, like in Mexico where Mr. Hugo Benítez (the technical assistant to the above mentioned programme) will feature on the Mexican BGBD project team. Most of these efforts will materialize at later stages of the project however.

Activity 2.6. Development and validation of soil biological indicators of agroecosystem health.

Impacts of different land use systems on the native populations of rhizobia in the soil at the Potrerillo microwatershed, Cauca, Colombia

L.F. Escobar^{1,2}, N. Asakawa¹, E. Barrios¹, A. Varela²

1 Tropical Soil Biology and Fertility Institute, Centro Internacional de Agricultura Tropical (CIAT). Cali, Colombia.

2 Departamento de Biología, Pontificia Universidad Javeriana, Bogotá, Colombia.

An exploratory study was conducted in the Potrerillo Microwatershed, Cauca department, in order to assess the impact of different land use systems on the abundance of native rhizobial populations in the soil. Soils under five land uses and local land classification units: Forest, Coffee plantation, Pasture, "Angry Land" and "Tired Land", were compared. Physical, chemical and biological soil properties were also measured and correlation studies with the abundance of native rhizobial

populations abundance were conducted. Consecutive soil samplings were carried out during the wet, intermediate and dry seasons respectively. A composite soil sample was taken in each farm, for a total of 20 samples per sampling date, and the abundance of the native rhizobial populations was determined using the MPN (Most Probable Number) technique. Physical (texture), chemical (pH, C, N, organic matter fractionation, P, K, Ca, Mg, Al) and biological (N mineralization potential) measurements were also made on the same samples. A significant land use system effect was detected on the abundance of native rhizobial populations during the dry season. The greatest abundance of native rhizobia was found in soil from "Tired Land" and Pasture land uses. The abundance of rhizobia ranged from 0 - 4.5×10^6 cells/ g dry soil and no significant effect of sampling date was found. According to the principal component analysis, the soil texture and organic matter available for mineralization processes, associated with adequate humidity conditions and sand percentage, were the edaphic variables responsible for discrimination among land uses. Discrimination was only observed between soils from Forest and "Angry Land". Nevertheless, these variables were not related to the abundance of native rhizobia in the soil. Indications were found that other factors, such as presence of legumes in the different types of land uses, could be influencing the abundance of native rhizobia in the soil.

Soil Macroinvertebrates as Affected by Land Use, Topography, and Sampling Depth in a Tropical Micro-watershed in the Colombian Andes

Fernando Sevilla^{1,2,3}, Thomas Oberthür¹, Edmundo Barrios², Otoniel Madrid¹

¹ *Land Use Project, Centro Internacional de Agricultura Tropical (CIAT), Cali, Colombia*

² *Tropical Soil Biology and Fertility Institute, Centro Internacional de Agricultura Tropical (CIAT). Cali, Colombia.*

³ *Universidad Nacional de Colombia, Palmira, Valle*

The main objective of the present work is to test the hypothesis that evaluation of soil macrofauna according to land use is not sufficient in hillside environments to develop thorough understanding of spatial distribution of abundance and diversity. It is argued that other factors, such as topography, would help us better understand the distribution of soil organisms within agricultural landscapes. To illustrate our argument, we apply statistical analyses to data of soil macroinvertebrates collected at the landscape scale in a small tropical watershed of the Colombian Andes.

The study was carried out in the Potrerillo micro-watershed in the mid-altitude Colombian Andes (Caldono district, Cauca department). The micro-watershed is located at 1400-1750 m, with the center of the study region at latitude 2° 48' N, longitude 76° 32' W. Rainfall follows a bimodal pattern, peaking in March-May and September-November, with a mean annual rainfall of 1900 mm, and the temperature usually ranges between 17-24 °C. The terrain of the 380-ha micro-watershed is undulating. Slope, ranging up to 30 degrees, was derived from a digital elevation model (Horn, 1981). Local farmers explicitly include the topographic positions of high plains, slopes, depressions, and alluvial valley bottoms in their land use allocations. The soils, derived from volcanic ashes, have been classified as Oxic Dystropepts. They are generally acid soils, with low to moderate levels of fertility, and favorable physical properties.

The cropping systems comprise annual staple (e.g., cassava, maize, and beans) and cash crops (e.g., peppers, tomato), intercropped perennials (e.g., coffee with plantain, coffee with papaya), fallows, and pastures. Thirty-nine percent of farming families in the watershed have a productive area of between 1 and 2 ha, and 38% own between 3 and 8 ha. Although cropping systems include a range of crops, most of the agricultural activities are centered around coffee production and a few annual market crops. Some farmers dedicate almost all their land to coffee, but most use up to 60% of their productive area for coffee systems, and grow annual cash and staple crops on the remaining land. The traditional coffee systems generally include various species of shade plants, including plantain, whereas farmers have recently shifted to growing coffee either in monoculture or together

with papaya. Only tomatoes, coffee, and plantains are likely to receive fertilization that includes mostly chicken manure, but is sometimes complemented by compost, coffee pulp, and commercially available compound fertilizers. Any fertilizer available is applied at a constant rate per plant, usually during planting (Cerón 2001).

To investigate soil macrofauna, the four local topographic positions were used as strata, and upon consultation with farmers, 40 fields were selected representing main land uses. Land uses included pasture, secondary forests, shade coffee, and natural fallows. Field centers were recorded using a global positioning system. At each site, two soil monoliths of 25 x 25 x 30 cm separated by 5 m were extracted following the method recommend by the Tropical Soil Biology and Fertility Institute (Anderson and Ingram, 1993). Each monolith was divided into four successive layers (i.e., litter, 0-10 cm, 10-20 cm, 20-30 cm), and macroinvertebrates were collected from each layer in the field. Adult macroinvertebrates were kept in alcohol solution (70%), and larvae and insects in formol (10%). In the laboratory, the macroinvertebrates were allocated to six main orders, including earthworms (Annelida), beetles and white grubs (Coleoptera), ants (Hymenoptera), myriapods (Chilopoda), pseudoscorpions (Pseudoescorpionida), and spiders (Arachnida). These were counted (abundance, individuals m⁻²), and weighed (biomass, g m⁻²). The biomass was corrected because all invertebrates lose weight as a result of fixation in alcohol (19% for earthworms, 9% for ants, 11% for Coleoptera, 6% for Arachnida and Myriapoda, and 13% for other macroinvertebrates).

Summary statistics were computed for all data, and for data organized according to topographic position, land use, and sampling depth. Analyses of variance (ANOVAs) were calculated for data organized according to these three factors. The different strata of the classification approaches, i.e., land use (natural pastures, secondary forests, shaded coffee, natural fallows), topography (interfluve, toeslope, backslope, depressions), and sampling depth (leave layer, 0-10 cm, 10-20 cm, 20-30 cm) were analyzed for their within-unit variability, following the procedures described by Leenhardt et al., (1994).

Additional soil cores were collected (0-20 cm), one at the field center, and five within a 5-m radius of it. The six samples were bulked, air-dried, and ground to pass through a 2-mm sieve. Soil analyses were conducted using standard laboratory procedures. The Bray-II test was used to characterize plant-available P, fractionation of SOM used the Ludox Method and potential N mineralization (PNM) followed standard methodology described in Anderson and Ingram (1993). Soil data were investigated jointly with soil macrofauna data using correlation analyses.

Table 7. Descriptive statistics of soil macrofauna groups: Information for biomass (BM, in g m⁻²) and abundance (D, in individuals m⁻²) is presented for all data (n = 160).

Means ^a	Soil macrofauna groups ^b											
	Ants		Spiders		Beetles		Earthworms		Myriapods		Pseudoscorpions	
	BM ²	D ³	BM	D	BM	D	BM	D	BM	D	BM	D
From all data:												
Mean	0.2	338	0.0	5	3.4	41	11.4	75	0.0	16	0.0	4
Min	0.0	0	0.0	0	0.0	0	0.0	0	0.0	0	0.0	0
Max	6.4	5256	2.0	104	64.7	480	202.8	1616	1.7	216	0.2	136
SD	0.8	659	0.2	13	8.1	64	27.9	170	0.2	35	0.0	17
Land use:												
SC, n=40	0.3 a	204 b	0.1 b	4 b	3.1 ba	32 b	14.1 a	62 ba	0.1 ba	28 b	0.0 a	12 a
NP, n=40	0.2 a	605 a	0.0 b	4 b	5.9 a	70 a	9.5 ba	131 a	0.0 b	6 c	0.0 a	0 b
NF, n=60	0.2 a	167 b	0.0 b	3 b	2.1 b	23 b	14.7 a	50 b	0.0 b	3 c	0.0 a	1 b
SF, n=20	0.2 a	590 a	0.1 a	16 a	2.7 ba	56 a	1.7 a	61 ba	0.2 a	48 a	0.0 a	4 b
Topographic positions:												
DEP, n=20	0.4 a	304 b	0.1 a	6 a	5.5 b	38 b	24.4 b	76 b	0.1 a	33 a	0.0 a	21 a
BS, n=100	0.2 a	274 b	0.0 a	6 a	2.1 cb	32 b	3.1 c	42 b	0.0 ba	16 b	0.0 b	2 b
TS, n=20	0.1 a	132 b	0.0 a	3 a	0.6 c	16 b	40.1 a	114 ba	0.0 b	3 b	0.0 b	1 b
IF, n=20	0.3 a	901 a	0.0 a	6 a	10.3 a	111 a	11.3 c	194 a	0.0 b	10 b	0.0 b	0 b
Sampling layer:												
LL, n=40	0.2 a	154 b	0.1 a	15 a	1.8 b	28 b	0.5 b	8 a	0.1 ba	18 b	0.0 a	13 a
L10, n=40	0.2 a	465 a	0.0 b	4 b	6.2 a	88 a	22.9 a	181 a	0.1 a	34 a	0.0 b	2 b
L20, n=40	0.3 a	414 ba	0.0 b	1 b	3.8 ba	35 b	17.2 a	90 b	0.0 b	8 cb	0.0 b	0 b
L30, n=40	0.2 a	321 ba	0.0 b	1 b	1.6 b	13 b	5.7 b	19 c	0.0 b	4 c	0.0 b	0 b

- a. SC = shaded coffee, NP = natural pasture, NF = natural fallow, SF = secondary forest, DEP = depression, BS = backslope, TS = toeslope, IF = interfluvium, LL = leaf litter, L10 = 0-10 cm, L20 = 10-20 cm, and L30 = 20-30 cm.
- b. Values followed by the same letter are not significantly different from one another at $P < 0.05$.

Results suggest that if soil macrofauna is studied at the landscape scale, it is not sufficient to emphasize land use as the only source of influence on the distribution of the various soil macrofauna groups. In fact, the distribution of some groups, including ants, beetles, and earthworms, appears to be less sensitive to impacts stemming from land use than to topographic position or sampling depth.(Table 7)

The abundance and vertical distribution of macroinvertebrates of the soil, such as spiders, myriapods, and pseudoscorpions, are negatively affected in land use where there is limited vegetative structure and leaf litter (natural pasture and natural fallow). However, in the topographic position categories, these same groups of macrofauna show greatest abundance in depressions, where shade coffee is located. This shows that both classification by land use and topographic categories give important and complementary information for a better understanding of the factors affecting the distribution of biomass and density of soil macroinvertebrates.

The sum of the mean densities of macrofauna groups, such as Coleoptera and earthworms, was greater in land uses with predominant herbaceous vegetation (natural pasture and natural fallow) compared with the densities of these same groups in uses with the presence of trees and higher vegetation (secondary forest and shade coffee). This shows an apparent relationship of certain macrofauna groups with determined land uses. This could be complemented with biodiversity studies. Shade coffee and secondary forest, although influenced by human activity, may be considered within programs of biodiversity conservation since it has been proved that they are refuges of diverse macroinvertebrate groups, among others, which can be of benefit as a source of biological control options in Andean agricultural landscapes.

Develop strategies for demonstrating improved BGBD management and for establishing farmer experimentation

Joshua J. Ramisch.

The development or design of management practices for the conservation of BGBD is aimed to be done in collaboration with the farmer community, and requires farmer participation. Aspects of farmer participation and application of farmer participatory approaches (FPA) are therefore considered to be part of developing strategies for demonstrating improved BGBD management.

At the Lampung BGBD workshop presentations were given and discussion held on farmer participatory approaches. These aimed mainly at raising awareness and defining the approach relevant to the project. It is clear that the communities and farmers need to be informed and involved in the project from the beginning. Communities have been addressed by organizing small workshops announcing and explaining the project or by gatherings with representatives of the communities. In some areas the project follows up on earlier community development projects and the sites have been chosen partly because of that reason indeed. Terms of engagement of the communities or farmers by the project have been discussed explicitly in a number of countries. In other cases efforts were directed more at the getting the consent of and assuring the involvement of the local authorities.

Community involvement will also be an aspect of the inventory of BGBD. However, work with farmers on current management practices is expected to start only in 2004.

Output 3 – Enhanced provision of soil-based ecosystem services (water quality and quantity, soil C, erosion control) within food secure land use systems

Output rationale

Interest in the quality and health of soil has grown with the recognition that soil is vital not only to production of food and fiber, but also the smooth functioning of the ecosystem, and overall environmental stability. Agriculture needs economic soil management practices that provide sufficient food and yet maintain environmental stability, ecological integrity, and the quality of essential resources. Strategies for sustainable management include conserving essential soil components, minimising erosion, balancing production with environmental needs, and making better use of renewable resources. In this regard, soil health is a major indicator of sustainable management. Criteria for indicators of soil health are useful in defining ecosystem processes and sensitivity to managements and climatic variations and in integrating physical, chemical and biological soil properties. Numerous experts e.g. agricultural specialists, producers, conservationists, and policy makers, etc might extensively need those criteria and data for sustainable management practices. Although soils gain certain biological, chemical and physical properties within a given ecosystem, the ultimate determinant of soil productivity, sustainability and health is the land manager. The assessment of health and quality of soil is the primary indicator of sustainable management and environmental remediation. Examples given include approaches for assessing soil health, defining the economic and environmental sustainability of land management practices, and translating our science into practice.

Milestones

1. Soil and crop management strategies to enhance water productivity and water quality developed.
2. Soil and crop management strategies developed to promote net accumulation of C and to reduce emission of greenhouse gases.
3. Soil and crop management strategies developed to reduce soil erosion and to maintain soil's productive capacity.

Activity3.1. Integration of farm, community, and watershed-level information related to the target ecosystem services across scales.

Published work

Biodiversity and ecosystem services in agricultural landscapes – are we asking the right questions?

M.J. Swift¹, A.-M.N. Izac² and M. van Noordwijk².

*¹Tropical Soil Biology and Fertility Institute of CIAT, ²International Centre for Research in Agroforestry
Agriculture, Ecosystems and Environment (In Press)*

The assumed relationship between biodiversity or local richness and the persistence of 'ecosystem services' (such as sustained productivity and regulation of water flow and storage) in agricultural landscapes has generated considerable interest and a range of experimental approaches, but the abstraction level aimed for may be too high to yield meaningful results. Many of the experiments on which evidence in favour or otherwise are based are artificial and do not support the bold generalizations to other spatial and temporal scales that are often made. Future investigations should utilise co-evolved

communities, be structured to investigate the distinct roles of clearly defined functional groups, separate the effects of between- and within-group diversity and be conducted over a range of stress and disturbance situations. An integral part of agricultural intensification at the plot level is the deliberate reduction of diversity. This does not necessarily result in impairment of ecosystem services of direct relevance to the land user unless the hypothesised diversity-function threshold is breached by elimination of a key functional group or species. Key functions may also be substituted with petro-chemical energy in order to achieve perceived efficiencies in the production of specific goods. This can result in the maintenance of ecosystem services of importance to agricultural production at levels of biodiversity below the assumed 'functional threshold'. However it can also result in impairment of other services and under some conditions the de-linking of the diversity-function relationship. Avoidance of these effects or attempts to restore non-essential ecosystem services are only likely to be made by land-users at the plot scale if direct economic benefit can be thereby achieved. At the plot and farm scales biodiversity is unlikely to be maintained for purposes other than those of direct use or '**utilitarian**' benefits and often at levels lower than those necessary for maintenance of many ecosystem services. The exceptions may be traditional systems where **intrinsic** or 'non-use' values continue to provide reasons for diversity maintenance. High levels of biodiversity in managed landscapes are more likely to be maintained for reasons of intrinsic ('non-use'), **serpentic** or 'option' values or utilitarian (direct use) than for **functional** or 'indirect use' values. The major opportunity for both maintaining ecosystem services and biodiversity outside conservation areas lies in promoting diversity of land use in ways that meet these requirements at the landscape scale. This requires however an economic and policy climate that favours diversification in land-use products and diversity among land users.

This review confirms two unsurprising but crucial elements for policy development: first that whilst a number of important analogies can be drawn across scales with respect to the management of the relationships between biodiversity and ecosystem services, there are also emergent properties that necessitate different approaches; second that the value placed on the relationship between biodiversity and function (ecosystem services) by individual land-users is markedly different than those perceived by the community at different levels of society. We have indicated a number of biological and socio-economic issues that need to be clarified in order to provide more explicit advice to policy makers. No single optimal value can be placed on the biodiversity within a landscape. Land-use decisions are likely to be optimised if decision makers can be provided with scenarios showing how various land-use combinations result in different levels of diversity and the efficiency of different ecosystem services. In so-doing it will be important to include aspects of temporal change as well as pattern on the landscape as both these factors influence the resilience of the landscapes which should be regarded as a factor of overriding importance. These scenarios can then be used to identify policy interventions and institutional arrangements necessary to achieve the desired objective, whether it is one dominated by agricultural productivity targets or the maintenance of ecosystem services or the conservation of biodiversity, or a combination of all three.

Activity 3.2 Management options to enhance soil-based ecosystem services, with an initial focus on the long-term impacts of organic resource management, designed and tested.

Published work

Carbon and nutrient accumulation in secondary forests regenerating from degraded pastures in central Amazônia, Brazil

Ted R. Feldpausch¹, Marco A. Rondón², Erick C.M. Fernandes¹, Susan J. Riha³ and Elisa Wandell⁴

¹Department of Crop and Soil Sciences, Cornell University, Ithaca, USA ²Centro Internacional de Agricultura Tropical, Apdo. Columbia ³Department of Earth and Atmospheric Sciences, Cornell University, USA ⁴Embrapa Amazônia Ocidental, Brazil

Journal of Ecological Applications (in press)

Over the past three decades, large expanses of forest in the Amazon Basin were converted to pasture, many of which later degraded to woody fallows and were abandoned. While the majority of tropical secondary forest (SF) studies have examined post-deforestation or post-agricultural succession, we examined post-pasture forest recovery in ten forests ranging in age from 0 to 14 yrs since abandonment. We measured aboveground biomass and soil nutrients to 45 cm depth, and computed total site C and nutrient stocks to gain an understanding of the dynamics of nutrient and C buildup in regenerating SF in central Amazônia. Aboveground biomass accrual was rapid, 11.0 Mg ha⁻¹ yr⁻¹, in these young SF. After 12 to 14 yrs, they accumulated up to 128.1 Mg/ha of dry aboveground biomass, equivalent to 25 to 50% of primary forest biomass in the region. Wood N and P concentrations decreased with forest age. Aboveground P and Ca stocks accumulated at a rate of 2.4 and 42.9 kg ha⁻¹ yr⁻¹; extractable soil P stocks declined as forest age increased. Although soil stocks of exchangeable Ca (207.0 ± 23.7 kg/ha) and extractable P (8.3 ± 1.5 kg/ha) were low in the first 45 cm, both were rapidly translocated from soil to plant pools. Soil N stocks increased with forest age (117.8 kg ha⁻¹ yr⁻¹), probably due to N fixation, atmospheric deposition, and/or subsoil mining. Total soil C storage to 45 cm depth ranged between 42 and 84 Mg/ha, with the first 15 cm storing 40 to 45% of the total. Total C accrual (7.04 Mg C ha⁻¹ yr⁻¹) in both aboveground and soil pools was similar or higher than values reported in other studies. Tropical SF regrowing on lightly to moderately-used pasture rapidly sequester C and rebuild total nutrient capital following pasture abandonment. Translocation of some nutrients from deep soil (>45 cm depth) may be important to sustaining productivity and continuing biomass accumulation in these forests. The soil pool represents the greatest potential for long-term C gains; however, soil nutrient deficits may limit future productivity.

In this study, we show that during early successional years, biomass accumulation in light to moderately used pastures is rapid after abandonment and that soil C storage is higher in older forests. However, a slower soil C accrual rate than regenerating SF in other regions, may negatively offset total long-term C gains. The higher proportion of soil C storage compared to aboveground pools will be an important consideration of future 'carbon credit' management, as this pool is more recalcitrant to perturbations. Aboveground C re-accumulation from post-burn values is high, yet represents a finite pool which is rapidly attained in a relatively short time-period. Managing forest regeneration to maximize soil C storage, rather than aboveground pools, may prove to be more useful or meaningful when attempting to increase SF C sequestration.

Furthermore, the colonizing vegetation can extract large nutrient quantities from the soil, even when in low supply. There was not only a shift of nutrients from soil to aboveground pools, but total system nutrient stocks were increasing over time. Most of the C, N, and

Mg were stored within soils, while P, K, and Ca resided within vegetation. This has important consequences to total forest nutrient stocks, in the event of removal of aboveground vegetation. In the absence of nutrient additions, removal of the vegetation a second time (pasture re-clearing or logging) could compromise the SF potential to regenerate as a result of nutrient limitations. Even after P fertilization when the areas were pasture, soil P stocks remained low. The vegetation was withdrawing more soil P than can be replenished, creating a soil P deficit which may limit system productivity. Low exchangeable soil Ca stocks seemed to be adequately replaced, apparently from atmospheric inputs and depths below 45 cm, as growing vegetation took up large nutrient quantities. Nevertheless, as vegetation Ca demands were high and soil stocks low, lack of Ca may limit future productivity.

These results demonstrate the regenerative capacity of tropical SFs to sequester C and to rebuild the nutrient capital following pasture abandonment. Aboveground carbon accrual is rapid but belowground gains represent the largest potential area for continued accumulation and management. Relocation of some nutrients from deeper soil layers may represent a substantial source of nutrients for plant growth and may be vital to sustaining long-term productivity and biomass accumulation. We recommend additional studies to explore P and Ca nutrient limitations to forest productivity and long-term measurements of soil nutrient fluxes and forest growth. Understanding nutrient limitations to resource capture will provide new options to manage forest regeneration and increase C accumulation on these globally important nutrient-limited soils.

Slash-and-char – a feasible alternative for soil fertility management in the central Amazon?

Johannes Lehmann^{1}, Jose Pereira da Silva Jr², Marco Rondon¹, Manoel da Silva Cravo³, Jacqueline Greenwood¹, Thomas Nehls⁴, Christoph Steiner⁴, and Bruno Glaser⁴*

¹ College of Agriculture and Life Sciences, Department of Crop and Soil Sciences, Cornell University, , USA; ² Embrapa Amazonia Ocidental, Brazil; ³ Embrapa Amazonia Oriental, Belem, Brazil; ⁴ Institute of Soil Science, University of Bayreuth, Germany.

The application of charcoal to nutrient-poor upland soils of the central Amazon was tested in lysimeter studies in comparison to unamended control soils to evaluate the effects of charcoal on plant nutrition and nutrient leaching. Testing the application of charred organic matter was stimulated by the fact that anthropogenic soils in the Amazon (so-called “Terra Preta”) with high soil organic matter contents contain large amounts of pyrogenic carbon. These soils also show high cation exchange capacity and nutrient availability. Charcoal additions significantly increased biomass production of a rice crop in comparison to a control on a Xanthic Ferralsol. This increase was largely an effect of improved P, K, and possibly Cu nutrition, whereas N and Mg uptake decreased in charcoal amended soils. In order to improve crop growth, fertilizer applications of N, S, Ca, and Mg may be necessary in addition to charcoal for optimizing rice growth. Combined application of N with charcoal resulted in a higher N uptake than what would have been expected from sole fertilizer or charcoal applications. The reason is a higher nutrient retention of applied ammonium by the charcoal amended soils. Charcoal applications therefore acted in two ways, first as a direct fertilizer and secondly as an adsorber which retained N. The amount of charcoal which can be produced from forest biomass is significant and corresponds to charcoal amounts needed for effectively improving crop growth. The slash-and-char technique is an alternative to burning of the above ground biomass and only the biomass from the same cropping area will be used for charring. Field trials need to be conducted to investigate the efficiency of charcoal production and applications under field conditions.

Carbon Storage in Soils from Degraded Pastures and Agroforestry Systems in Central Amazônia: The role of charcoal

Marco A. Rondon¹, Erick C.M. Fernandes², Rubenildo Lima³, Elisa Wandelli³

¹Centro Internacional de Agricultura Tropical CIAT. ²Department of Crop and Soil Sciences Cornell University - Ithaca, NY 14853 USA ³EMBRAPA - CPAA, Manaus, AM Brazil.
Proceedings LBA Meeting, Manaus, 2002

Charcoal is an ubiquitous constituent of the soils in the Central Amazon and appreciable amounts can be found even at 1 m depth. Coarse fragments are located preferentially at the surface layers showing high heterogeneity in its spatial distribution. Fine particles distribute rather homogeneously through the soil profile. Charcoal derived-C can account for as much as 15% of total soil C. Separation of coarse and medium size charcoal fragments is very important to allow appropriate comparison between SOC in different land use systems in areas where fire is a factor in the natural or human influenced management of the forest. Although charcoal separation and the assessment of black carbon is a time consuming process, given that charcoal is a remarkably stable pool, once a baseline has been established for a certain site, the same information could be used in future studies. Though various studies have shown that soils under pastures enable high rates of C sequestration (Fisher et al., 1994) in our sites, the lack of fertilizer inputs and the high initial degradation of the land prevented a significant accrual of SOC as compared to soils under secondary vegetation. Even under unfavorable initial conditions, agroforestry systems allow net C accumulation in soils, permitting the soils to move in a 10 years time period, from 87% to 95% of the total C stocks in the primary forest.

Effects of Land Use Change in the Llanos of Colombia on Fluxes of Methane and Nitrous Oxide, and on Radiative Forcing of the Atmosphere

M. Rondón¹, J.M. Duxbury² and R.J. Thomas³

¹ Centro Internacional de Agricultura Tropical (CIAT), Apartado Aéreo 6713, Cali, Colombia.

² Cornell University. Department of Soil and Crop Sciences. Bradfield Hall, Ithaca, NY. USA.

³ ICARDA, P.O. Box 5466, Aleppo, Syria (formerly CIAT, Colombia)

Agriculture, Ecosystems and Environment (in review)

The Colombian savanna (Llanos), covers 26 million hectares and is one of the few remaining frontiers where agriculture can expand. Current land use includes native savanna vegetation on clay-loam and on sandy-loam Oxisols, gallery forest, introduced improved pastures and cropland. Little is known about the fluxes of greenhouse gases in this ecosystem. Here we report field measurements of fluxes of methane and nitrous oxide for various land uses and estimates for their annual budgets in the Llanos. Emission of greenhouse gases due to burning of native vegetation and the contribution of methane emissions by termites and cattle have been included to estimate the radiative forcing potential of the atmosphere (global warming potential) for the Llanos.

Soils under pastures were found to be net annual sources of methane, while soils under other land uses were net annual sinks via methane oxidation. Soils under gallery forest showed the highest methane sink. Soil texture influenced fluxes of GHG. Annually, sandy-loam soils oxidized more methane than clay-loam soils (both under native vegetation). Soils of the Llanos were estimated to oxidize 6.4Gg/y of methane. Soils of the gallery forest covering 10% of the area of the Llanos, represent 48% of total methane sinks. All soils were minor sources of nitrous oxide with land under upland rice cultivation having the highest emission rates due to the input of fertilizer-N or green manure. Net emission by soils was estimated to be 12.4 Gg/y and soils were the major factor in the nitrous oxide budget of the region.

Annual emission of CH₄ by cattle (0.10Tg) is the main single source of this gas in the Llanos followed by direct emissions from biomass burning (0.06Tg/y). Termites contributed very little to net methane emissions. Considering the main sources and sinks of trace gases, it was estimated that the Llanos is a net source of 0.164 Tg CH₄/y and 0.021 Tg N₂O/y. For a 20-year time horizon, the global warming potential of the Llanos under current land use distribution is 22.2 Tg CO₂ equivalents which is less than 0.005% of estimated global planetary radiative contribution. Therefore, the Llanos can be considered as an "environmentally friendly ecosystem". The doubling in area under improved grass-legume pastures and cropland expected by the year 2020 will reduce this contribution to 16.5 Tg CO₂ equivalents mainly due to the reduction in emissions from biomass burning and to CO₂ sequestration as soil organic carbon by deep-rooted grasses.

This study presents the first data set on fluxes of methane and nitrous oxide for the Colombian Llanos. Results indicate that gallery forest is an important sink for atmospheric methane, while savannas are a minor sink. Therefore, preservation of the gallery forest should be of priority concern as this environment also provides a home for a large biodiversity of endemic plants and animals.

Conversion of soils into cropland does not reduce their methane oxidizing capacity and some of the management practices could even increase their sink strength. This may be the result of eliminating some of the physical constraints that limit the gas exchange between soil and the atmosphere (soil compaction, surface sealing etc.). On the other hand it also increases emissions of nitrous oxide and is equally expected to increase losses of soil carbon as a result of tillage. Despite this, given that the main contributing factors (burning and cattle) are excluded in cropland, it can be anticipated that agriculture will be a better option than savanna for reducing the radiative forcing of the Llanos.

Emission of methane by biomass burning is a key factor in the balance of this gas in the Llanos. Any action that can reduce the area submitted to burning and or the frequency of burning events, will improve the radiative balance in the region. In this respect, conversion of savanna into croplands or pastures is clearly an advantage because burning is eliminated in such land uses. Promoting the re-colonization of the land by gallery forests constitute a win-win situation as it will not only eliminate the burning, but also will increase the methane soil sink strength.

Fire plays a key role in maintaining the biodiversity in the savanna, in addition to other important though not fully understood ecological roles. Consequently, complete suppression of the burning is not a desirable option. Appropriate corridors to maintain the continuity of the savanna ecosystem should always be considered.

Cattle-associated emissions of methane dominate methane budgets in the Llanos. Improving estimates of their actual contribution as well as exploring promising opportunities to reduce their impact by offering forages of higher nutritional value, are important topics for research in the near future.

Natural ecosystems as well as converted lands constitute small net sinks for N₂O in the Llanos. Emission rates are related with the amounts of nitrogen cycled in the soil; nitrogen inputs in the form of fertilizer or green manure cause enhanced emissions. Strategies to manage these inputs in order to minimize nutrient losses and reduce environmental impact require further attention.

In general fluxes of methane and nitrous oxide from soils in the Llanos can be considered low, but fall within the range reported for similar environments in Africa (Seiler et al., 1984), Central America (Mosier et al., 1998), Brazil (Lauren et al., 1995) and Venezuela

(Scharffe et al., 1980), and even for tall grass prairies in temperate regions (Tate and Striegl, 1993).

Though pastures will increase methane emissions from cattle due to the increase in the stocking rate as compared to savanna, by avoiding the fire and by sequestering atmospheric CO₂ in the form of soil organic carbon, pasture is the only land use option identified in this study, that can shift the land from a net source into a net sink of atmospheric GHG's.

This study has shown that the Llanos are only a very minor contributor to the warming of the atmosphere and that expected intensification of agriculture and cattle production in the coming two decades would not have negative effects on the radiative forcing potential of the region. Despite this, there are other well identified constraints for the sustainability of the natural resource base, whose impact should never be forgotten. Pasture degradation is major cause of pasture abandonment especially in the Brazilian Cerrados and the Amazon. Degradation could result not only in reduced C sequestration in soils but even turn them into net sources of Carbon (Da Silva et al., 2000). Though current pasture degradation is not too severe in the Llanos, unless appropriate management practices were adopted, this could become a critical problem in the region, whose environmental consequences are still to be evaluated.

In the jargon of optometrics, 20-20 means perfect vision. We hope that appropriate vision will be used by policy makers in the design of development plans for the Llanos which allows the region to continue being an environmentally friendly ecosystem in the year 2020.

Activity 3.3 Local and formal monitoring systems to evaluate the impacts of ISFM options and other land management practices on ecosystem services developed.

Activity 3.4 Trade-offs between agricultural productivity and ecosystem service provision evaluated.

Completed work

Validation of the methodology for the economic assessment of soil losses in steeplands of Nicaragua.

M. E. Baltodano, M. Ayarza and S. Rivera.

Soil conservation is often mentioned as a key component for the development of sustainable agriculture. Although there is information quantifying soil retention under improved soil conservation technologies, there is still a lack of methods to value the economical benefit of soil conservation. The objective of this work was to validate and improve the MSEC tool to assess the economical evaluation of soil erosion losses. The methodology was introduced by MSEC representatives to MIS partners in 2002. A proposal was developed to validate the methodology for hillsides of Nicaragua.

The work was conducted in the Calico River Watershed in San Dionisio, Nicaragua. Dominant landscape is very hilly (45-75% slope) over shallow clayey Inceptisols. Traditional agricultural system in the region is based on planting maize and beans on burned fields with minimum use of external inputs. The field work started with the identification of 20 farms using soil conservation practices and another 20 control farms with no experience in their use. Farmers from each group were asked to give reasons in favor or against using soil conservation.

Four major soil conservation practices were selected for the study: 1) contour living fences; 2) Stone terraces; 3) no burning and; 4) contour trenches. We found that most farmers do not use a single conservation practice but a mixture of them. For these reason, we group them into several combinations, Species used as living fences were **Cajanus**, **Glyricidia Citronella** and inless scale **Mucuna** and Sugar Cane.

In order to perform the economical analysis we recorded crop yields for the past three years for each system with the help of participating farmers. Parameters used in the for the economical evaluation were: 1) benefit-cost ratio (B/C) and the Net Present Value (NPV) for three years ($Bt-Ct/(1+r)^t$) with a 18% discount rate.

Soil retained by conservation practices was measured using a combination of field techniques (PASOLAC, 1999). Soil samples were sent to the lab to determine nutrient concentrations. This allowed us to calculate total amount of nutrients retained by each conservation technique. An overall assessment of cost and benefits of soil conservation including crop yields, soil retained and added value of living fences is presented.

Farmer perceptions about use of soil conservation practices

Farmers using soil conservation indicated that the main reasons behind using soil conservation were: 1) soil is not lost from the plot; 2) organic matter accumulated on the surface "entertain" pests and reduce their attack to crops; 3) improved soil moisture; 4) reduced weed pressure and; 5) more stable crop yields.

Farmers not using soil conservation indicated that main reasons for not using them were: 1) tradition to use burning to clean the plot before planting; 2) soil conservation practices like terraces reduce their cropping area or competes with the crop, 3) crops growth better on burned plots; 4) pest problems are lower on burned lands; 5) maintenance of conservation practices demands labor and time and; 6) lack of knowledge about the benefits of soil conservation.

Crop yields and economical benefits

Figures 15 and 16 show maize and bean yields with and without soil conservation. Yields were very variable. For this reason we found no statistical differences between soil conservation practices and the control without conservation. Reasons for this are associated to variable management practices among farmers even under the same conservation practice (different varieties, plant densities, weed control and variable weather conditions). On the other hand the effectiveness of the conservation practices was variable due to lack of maintenance. The benefit/ cost for no conservation was 1.6 for Maize and 2,8 for beans.

Figure 15. Maize yields under several conservation practices in farms of San Dionisio, Nicaragua

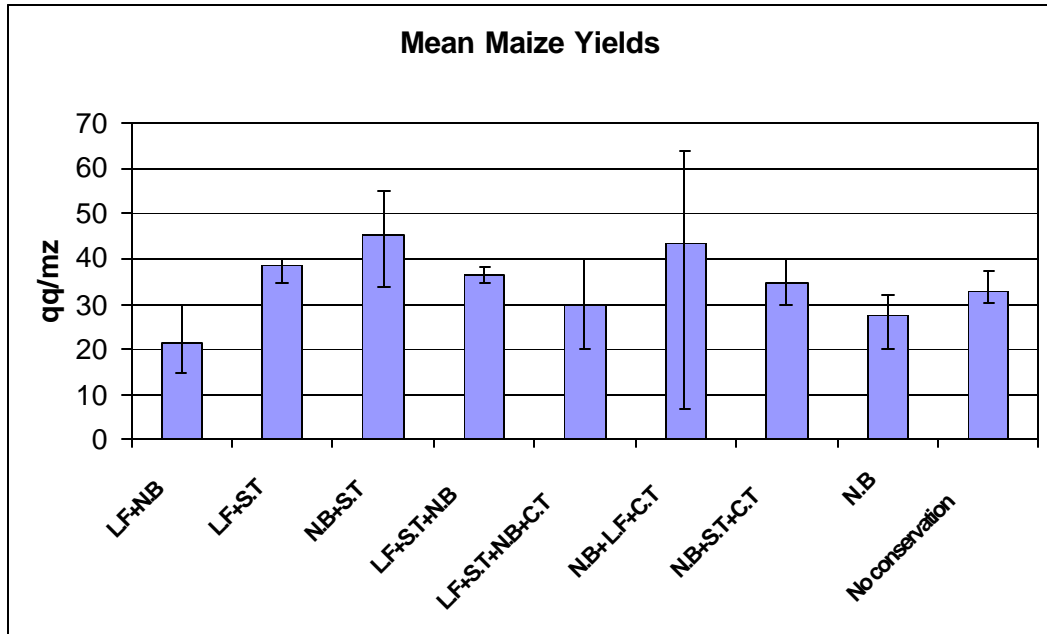

Note: 1 qq/mz = 0,064 t/ha

N.B= no burning; L.F= living fences; S.T= Stone terraces; C.T= Contour trenches

Figure 16 . Bean yields under several conservation practices in farms of San Dionisio,

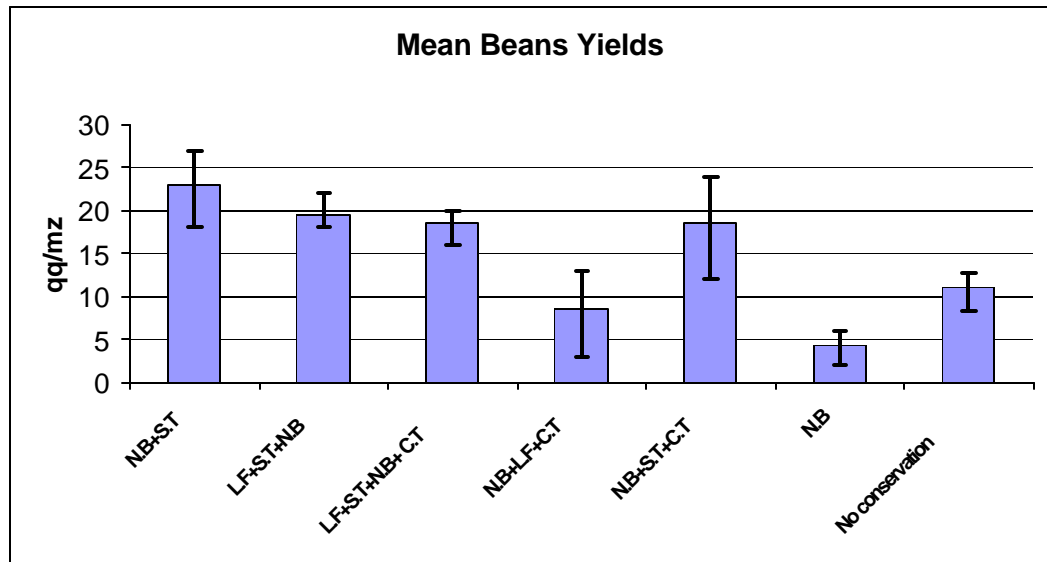

Nicaragua

Most conservation practices had a positive NPV for the time scale used (3 years). NPV estimates are very sensitive to time horizons and discount rates and in some cases several assumptions have to be made (T. Enters, 2000). Most poor farmers have a limited time horizon and limited resources for invest and maintain conservation practices.

Additional benefits of conservation practices.

The use of living fences for soil conservation had a positive impact on the profitability of the system. Table 8 shows the calculation performed for various species. In all cases there was a positive ratio and average of 1.67.

Table 8. Cost and benefits of using several species as living fences for soil conservation

Species	Costo of (Establishment) (US\$)	Profit (US\$)	Benefits	Maintenance costs
Cajanus spl	7.26	24,00	Seed, animal feeding and household consumption	1,87
madero negro	7,26	26,66	Posts for fencing, seed	3,33
Cajanus+ mucuna	6,20	40,00	Household consumption	0,77
Vetiver o limoncillo	28,33	27,20	Medicinal herbs , Propagation material	1,66
Sugar cane	41,66	33,33	Animal feeding material for construction	3,33

Economical value of soil retained

Mean soil retained was 31 t/ha with a range of 2-73 t/ha. Greatest soil retention was obtained using stone terraces. Estimates the cost of reposition of soil retained indicated that the value per ton of soil retained was about US\$ 2. This value was considered extremely low for farmers practicing soil conservation.

Inclusion of economical benefits derived from soil retention and multiple uses of species used as contour living fences increases benefit/cost ratio by 15% as compared to the traditional maize-bean system without conservation.(Table 9)

Table 9. Overall benefits (US\$/ha) of soil conservation practices in steeplands of San Dionisio, Nicaragua.

BENEFITS	WITHOUT CONSERVATION	WITH CONSERVATION
Gross margin from maize	200	233
Gross margin from beans	250	267
Living fencing	0	30
Soil retained	0	54
Total Benefits	450	584
COSTS		
Maize crop	134	134
Bean crop	143,6	143,6
Cost of reposition	52,33	0
Inputs for living fences	0	72,66
Labour to establish fences	0	42.12
Total Costs	329,9	392,4
Net Benefits	120,1	191,6
Benfit/Cost ratio	1,30	1.49

Conclusions

1. Production systems of small farmers in hillsides are very heterogeneous and for this reason it is very difficult to quantify economic benefits of soil conservation based exclusively on crop yields.
2. Analysis of profitability of soil conservation practices have to take into account economical benefits of retained soil and added value provided by trees and living fences.
3. Long-term estimates of soil conservation practices using NPV values might not be useful for small farmers that do not own land and have limited resources to maintain them.
4. Economic analysis based on total yields is not realistic for subsistence farmers since a large part of their production is used for household consumption.
5. Long-term profitability of soil conservation can be diminished by lack of labor and resources to maintain their effectiveness.
6. Profitability of soil conservation is higher in beans than for corn.
7. Estimated cost of US\$ 2 per ton soil retained using conservation practices was very low for farmers.

Activity 3.5 Policy and institutional mechanisms that provide incentives to landholders to manage ecosystem services in a sustainable manner developed.

Output 4: Strategies for scaling up and out of ISFM practices developed, implemented and evaluated

Output rationale

To see ISFM principles applied by a wide variety of actors at scales ranging from the farm level to the national or continental levels means addressing the problems of how to use knowledge gained at one scale to interpolate or extrapolate knowledge for decision making at another scale. In recent years TSBF and other natural resource management programmes have confronted the challenge of extending their research findings for successful impact on farm. Conveying the numerous components and complexity of interactions involved in natural resource management is very different from the extension of new crop varieties through demonstration plots. In the latter, the results are quick and easy to see, whereas the results and possible benefits of natural resource management strategies may not be readily apparent and often take time to manifest themselves. The rise of the participatory movement in agricultural research has also emphasized the importance of responding to farmers' perceptions and needs rather than assuming that formal science provides solutions in its own right.

TSBF has responded to this challenge by developing a research approach that includes:

- ?? Characterizing soil fertility management problems and practices according to typologies of farmer practice and relating these practices to farmers' natural, socio-economic and managerial resources;
- ?? Developing soil management options that provide flexible responses to this range of farmer circumstances; and
- ?? Developing methods for disseminating these options through processes of interactive learning and evaluation among farmers, extensionists and researchers.

Milestones

1. Alliances strengthened and developed to scale-up and scale-out ISFM strategies.
2. Simulation models used to build scenarios for improved crop-livestock productivity in participation with farmers.
3. Decision support tools for ISFM developed and disseminated.
4. Opportunities for integrating local and scientific knowledge systems identified and hybrid technologies developed

Activity 4.1 Methods for integrating and strengthening local and technical knowledge of soil processes, soil quality, ecosystem services and BGBD developed.

Published work

Implications of local soil knowledge for integrated soil fertility management in Latin America

E.Barrios¹ and M.T. Trejo²

¹*Centro Internacional de Agricultura Tropical (CIAT), Cali, Colombia*

²*Centro Internacional de Agricultura Tropical (CIAT), Tegucigalpa, Honduras*
Geoderma, 111(2003) 217-231

The increasing attention paid to local soil knowledge in recent years is the result of a greater recognition that the knowledge of people who have been interacting with their soils for long time can offer many insights about the sustainable management of tropical soils. This paper describes two approaches in the process of eliciting local information.

Case studies show that there is a consistent rational basis to the use of local indicators of soil quality and their relation to improved soil management. The participatory process used is shown to have considerable potential in facilitating farmer consensus about which soil related constraints should be tackled first. Consensus building is presented as an important step prior to collective action by farming communities in integrated soil management at the landscape scale. Taking advantage of the complementary nature of local and scientific knowledge is highlighted as an overall strategy for sustainable soil management.

The case studies presented showed that there is a consistent rational basis to the use of local indicators of soil quality. The use of key-informants was an effective method to elicit local information about soils and their management. In addition, participatory approaches involving group dynamics and consensus building are likely to be key to improve soil management beyond the farm-plot scale to the landscape scale through the required collective action process.

Native plants as local indicators of soil quality were important local indicators of soil quality in all three case studies associated with modifiable soil properties. The use of indicator plants, belonging to the local knowledge base, when related to management actions could ease adoption of improved technologies. This approach would allow the use of plants as indicators of soil quality to which local farmers can relate more closely than to common agronomic measures such as phosphorus availability, organic matter content or pH value. Additional research could also include further integration of scientific spatial analysis (i.e. GIS, topographic modeling) with the spatial perception of natural resources by farmers aiming at improved implementation of site-specific management.

Completed work

Developing an approach through South-South collaboration for integration of local and scientific knowledge systems about soils and their management

*Barrios E.*¹, *Delve R.J.*², *Bekunda M.*³, *Mowo J.*⁴, *Agunda J.*⁵, *Trejo M.*⁶, *Ramisch J.*⁷, *Thomas R.J.*^{1,8}

¹ *TSBF Institute of CIAT. Centro Internacional de Agricultura Tropical (CIAT), Cali, Colombia,*

² *TSBF Institute of CIAT. Centro Internacional de Agricultura Tropical (CIAT), Kampala, Uganda;*³ *Department of Soil Science, Makerere University, Kampala, Uganda;*⁴ *African Highlands Initiative (AHI), Leshoto, Tanzania;*⁵ *CARE, Homabay, Kenya;*⁶ *TSBF Institute of CIAT. Centro Internacional de Agricultura Tropical (CIAT), Tegucigalpa, Honduras;*⁷ *TSBF Institute of CIAT. Centro Internacional de Agricultura Tropical (CIAT), Nairobi, Kenya and*⁸ *current address International Center for Agricultural Research in the Dry Areas (ICARDA), Aleppo, Siria.*

Local soil knowledge has received increasing attention in recent years because of greater recognition that insights from local land managers constitute valuable inputs towards the sustainable management of tropical soils. A participatory approach in the form of a methodological guide has been developed in order to identify and classify local indicators of soil quality related to permanent and modifiable soil properties. This methodological guide was initially developed and used in Latin America and the Caribbean (Honduras, Nicaragua, Colombia, Peru, Venezuela, Dominican Republic), and during adaptation and use in the East African context (Uganda, Tanzania, Kenya) it was further improved. Valuable contributions from collaborators in Africa have now been incorporated into a new Spanish version of the methodological guide completing a full South-South collaboration cycle. This methodological tool aims to empower local communities to better manage their soil resource through better decision making and the development of local soil monitoring systems. It is also designed to steer soil management towards developing practical solutions to identified soil constraints, as well as, to monitor the impact of management strategies implemented to address such constraints. The methodological

approach presented here constitutes one tool to capture local demands and perceptions of soil constraints as an essential guide to relevant research and development activities. A considerable component of this approach involves the improvement of the communication between the technical officers and farmers and *vice versa* by jointly constructing an effective communication channel. The participatory process used is shown to have considerable potential in facilitating farmer consensus about which soil related constraints should be tackled first. Development of local capacities for consensus building is presented as an important step prior to collective action by farming communities resulting in the adoption of integrated soil fertility management strategies at the landscape scale.

More often than not technical solutions to soil degradation abound but are often left on the scientist shelves because they are developed without the participation of the land user or do not build on local knowledge of soil management. Participatory approaches involving group dynamics and consensus building are likely to be key to adoption of improved soil management strategies beyond the farm-plot scale to the landscape scale through the required collective action process. Action plans developed by local actors as a result of consensus building and new insights derived from the training exercise become a vehicle by which profitable and resource conserving land management is locally promoted and widely adopted. Taking advantage of the complementary nature of local and scientific knowledge is highlighted as an overall strategy for sustainable soil management.

The development and use of this methodological guide has been a good example of a full cycle of 'South – South' cooperation where experiences from Latin America were brought and adapted to the African context, and feedback during adaptation process in Africa has helped further improvement of the Latin American guide.

On-Going and Future Work

Activity 4.2 Participatory and formal economic methods of evaluating soil management practices developed and tested.

Completed work

Evaluation of current ISFM options by participatory and formal economic methods

*JJ Ramisch and I Ekise
TSBF-CIAT*

Declining soil fertility problem is the single greatest threat to food security and livelihoods in Western Kenya. Findings of most soil fertility research work in the region indicate that the soils of this region are generally deficient in Nitrogen and Phosphorus nutrients. This problem has been caused by high population density and poor farming methods. For instance in Emuhaya area, farmers continuously crop their fields with minimal use of inorganic or organic fertilizers. This type of farming can not be sustained in the long run and if not checked could lead to deterioration in the farming environment. Some of the indicators of a deteriorating environment are; sharp decline of crop harvests, high incidences of crop and animal pests and diseases, frequent famine, deteriorating farm incomes among others.

A baseline survey of soil fertility management practices and socio-economic conditions was completed and analysed for 314 farmers in the West Kenya site. The methodology was shared with the Ugandan and Tanzanian sites. These data are being compiled and analysed along with comparable studies conducted at the other

BMZ project sites in West Africa (Togo and Benin) to produce a scientific paper relating soil fertility management practices to the contrasting socio-economic and agro-ecological conditions of the sites.

Farmers, extension, and KARI-Kakamega field staff were trained in participatory monitoring and evaluation methods. Several forms of farmer recording keeping were introduced in 2001 to monitor and evaluate progress with the soil fertility management technologies. However, lack of funds has limited follow-up, which has led to widely varying levels of farmer interest and disparate standards of data collection.

A good number of partners have since initiated trials in the region whose main goal was to enable farmers to produce agricultural products while reversing nutrient depletion on their soils. The purpose of this was to increase the farmer's capacity to develop, adapt and use integrated nutrient management strategies. The integrated soil fertility management options tried include; biomass transfer using *Tithonia diversifolia*, use of improved fallow plants (*Mucuna*, *Crotalaria grahamiana*, *C. ochroleuca*, *C. paulina*, *Canavalia*, *Sesbania sesban* etc), use of high quality compost, integration of inorganics and organics. The partners in this research include; the African Highlands Initiative (AHI), Tropical Soil Biology & Fertility Programme (TSBF), International Centre for Research in Agroforestry (ICRAF), Kenya Forestry Research Institute (KEFRI), Kenya Agricultural Research Institute (KARI), Ministry of Agriculture Extension service and Farmer research groups. The research work was implemented through the framework of participatory technology development and transfer.

The initial target number of farms was 60 located in 5 villages of Ebusiloli sub-location of Bunyore East location in Emuhaya division of Vihiga district. The work was implemented through the farmer research group framework, which focused the village as the unit of research work. Each village was organized into a research group with elected officials managing their respective groups.

The specific objectives of this study are:

- i) To quantify the costs and benefits of the practiced ISFM technologies in order to show the profitability of each technology.
- ii) To conduct participatory ranking of the ISFM options based on farmers criteria and perceptions.
- iii) To identify the constraints facing the ISFM practitioners and possible solutions to overcome them in order to improve the adoption of technologies being practiced.
- iv) To build the capacity of the farmer field schools to innovate and share the results for collective action.

The FFS Framework: The farmer field schools work together to implement the study. Suitable farms were identified and the owner contracted using the procedures of TSBF and ICRAF being currently used to implement other trials. The decision support systems (DSS) layout for the trial (see section 2.3) in Emuhaya was adopted. There is concern from the farmers that treatment plot sizes need to be increased for more visibility. They propose to have 10 m x 10 m plots. The farmer field schools propose to include the local (indigenous) plants and test them as well. The treatments will be randomly selected and established.

Activity 4.3 Evaluation of ISFM options for improved soil health and farmers' income.

Completed work

Financial benefits of *Crotalaria grahamiana* and *Mucuna pruriens* short-duration fallow in eastern Uganda

Tumuhairwe, J.B¹., B. Jama²*, and R. Delve³, M.C. Rwakaikara-Silver¹

¹Makerere University, Department of Soil Science, P. O. Box 7062, Kampala, Uganda

²International Centre for Research in Agroforestry, P. O. Box 30677, Nairobi, Kenya

³Tropical Soil Biology and Fertility (TSBF) and International Centre for Tropical Agriculture (CIAT), P. O. Box 6247, Kampala, Uganda

Crotalaria grahamiana and *Mucuna pruriens* improved fallows are gaining popularity among smallholder farmers in Uganda to address soil fertility decline. The technology supplies nutrients and increases crop yields but its economic viability is uncertain in eastern Uganda. Therefore, two researcher-managed experiments were established in Tororo District, eastern Uganda to determine the financial benefits of the *C. grahamiana* and *M. pruriens* improved fallow compared to farmers' practices of natural fallow, compost manure and continuous cropping. Higher returns to land were obtained from improved fallow compared to farmers' practices. *C. grahamiana* realised US\$267.4 (Dina's site) and \$ 283.2 (Geoffrey's site), and *M. pruriens* had \$284.1 (Dina's site) and \$248.7 (Geoffrey's site) compared to natural fallow \$223.3 (Dina's site) and \$274.3 (Geoffrey's site), compost manure \$70.9 (Dina's site) and 114.2 (Geoffrey's site) and continuous cropping \$314.2 (Dina's site) and \$314.2 (Geoffrey's site) per hectare. Improved fallows saved on labour compared with continuous cropping and compost manure except for natural vegetation fallow. Higher returns to labour were obtained through use of improved fallow than compost manure and continuous cropping. Returns to labour of \$0.54 day⁻¹ were obtained for compost manure (at Dina's site), which is less than the wage rate at \$0.57 day⁻¹ indicating a loss in labour invested.

An assessment of the profitability and acceptance of alternative soil improvement practices in Tororo district, Uganda)

Tumuhairwe, J.B¹., B. Jama²*, and R. Delve³, M.C. Rwakaikara-Silver¹

¹Makerere University, Department of Soil Science, P. O. Box 7062, Kampala, Uganda

²International Centre for Research in Agroforestry, P. O. Box 30677, Nairobi, Kenya

³Tropical Soil Biology and Fertility (TSBF) and International Centre for Tropical Agriculture (CIAT), P. O. Box 6247, Kampala, Uganda

Agricultural production in Eastern Uganda is declining due to increasing population pressure on the land. A resultant feature is the dependence of soils on external inputs to attain acceptable crop yields. Resource-poor smallholder farmers, who form the majority of the farmer population in this area, can typically ill-afford recommended levels of inorganic fertilizer use to replenish lost nutrients. Alternative options to expensive and often unavailable inorganic fertilizer use for this small scale farmer population include the integrated use of inorganic fertilizer and organic inputs such as legume cover crops and biomass production shrub and tree technologies. These technologies were incorporated into the farming systems in Eastern Uganda, Tororo district, in 1998 through farmer groups. An economic evaluation of 10 researcher-designed-farmer managed maize trials using *Mucuna pruriens* and *Canavalia ensiformis* fallow and *Tithonia diversifolia* biomass land use systems were conducted. The profitability was determined using gross margins, after which modelling produced the optimal land use system. A survey of 108 respondents was also conducted to determine the acceptance and farmer-perception of 8 previously exposed shrub and tree species. The economic evaluation favoured the use of Integrated Nutrient Management of soil amendments. The 100% incorporation of *Mucuna*

produced the highest benefits of 185,641/= ha⁻¹ as opposed to the net benefit of 134,901/= that would be produced in the optimal solution from 0.6 ha using 191 labour days. The application of 0.91t ha⁻¹ + N biomass system would produce the highest benefits of 445,744/= ha⁻¹ with an optimal net benefit solution of 342,080/= on 0.8ha using 263 labour days. The survey results showed that in the sample size, the acceptance rate was 53 percent. The age and area under shrub were significantly different (0.01) across accepters and non-accepters. The cultivated area (0.1) and employment activities (0.05), institutional support such as belonging to groups and number of extension visits significantly also differed. Alternative uses of shrubs and trees, use of other complimenting inputs and perceptions of the soil fertility were highly significant across acceptor category. Farming experience and use of farmyard manure were not significant. *Sesbania sesban*, and *Mucuna pruriens* were found to be the most popular shrubs (36.69%, and 20.6% respectively) and problematic (36.22%, and 25.20% respectively). Popular uses were weed suppressant uses (17.5%) and fuel wood production (23%) for 7 out of 8 shrubs. Major reported problems were the increased labour demands, (21.5%), pest and vermin association (25.3%), and access to planting material and seed (26.7%). Further economic studies that will determine the optimal levels at which the incorporation of livestock management systems into the cropping systems using integrated nutrient management options are recommended. Farmer designed-farmer managed trials would establish preferred farmer management practices to ensure sustainability of these land use systems.

A Comparative Analysis of the Profitability of using Pit-stored Manure on Field and Vegetable Enterprises in Zimbabwe

Farai Zinyama and H K.Murwira

University of Zimbabwe, Department of Agricultural Economics and Extension, TSBF-CIAT, P.O.Box MP228 Mt.Pleasant, Harare, Zimbabwe

Farmers have adopted various best-bet technologies to improve their yields, such as the use of pit-stored manure. The focus has been to improve household food security status through applying the improved manure on field crops especially maize, however informal surveys conducted in the study sites have found out that the pit manure is now being allocated in both field and garden enterprises. Given this scenario, smallholder farmers are faced with a decision problem pertaining how much manure to allocate between the field and garden enterprises to maximise profits for the household. The overall objective of this study was to establish the profitability of using pit-stored manure on field and garden enterprises by the communal farmers. A survey questionnaire was used to collect data. Tools used in data analysis include gross margin, linear regression, linear programming, t-tests and descriptive statistics.

The study established that various socio-economic factors such as availability of labour, cattle ownership, size of land a farmer owns and the age of the household are instrumental in the farmers' overall decision to apply more manure either to the garden or to the field. Although most farmers in the study are applying more manure to the field than to the garden on a per unit basis, the study established that farmers get more returns from the garden enterprises. This suggests that lack of a well-developed policy framework to disseminate research information to smallholder farmers can hinder attainment of optimal productivity through inefficient resource allocation. The study also established that there is no difference in food security status between households due to differences in manure allocation. The study further established existence of inefficient manure allocation between field and vegetable enterprises. The observed current trend in shifting of manure from the field to the garden is economically rational and there is need to strike a balance between profit maximisation and ensuring food security. The study recommends effective information dissemination and enhancement of the farmers' capacity to analyse trade-offs of alternative management options.

Legume green manuring for soil productivity improvement in eastern Uganda.

*M.J. Kuule, M.A. Bekunda and R. Delve.
Paper in preparation form Masters thesis.*

Declining per capita food production has been blamed on continuous cultivation of the land resource without adequate replenishment of soil nutrients. A recent fertilizer use survey reported a less than 1kg of nutrient fertilizer per hectare per year. Yet rates of nutrient uptake by plants through crop harvest or loss through leaching and other loss processes from arable land are much higher. This leads to serious nutrient depletion. Green manuring offers an alternative source of nutrients especially N in a relay system of intercropping. A study to demonstrate this potential and to identify suitable legume species for the area was conducted on farmers' fields in two sub counties, Kisoko and Osukulu in Tororo district. Four legume species, *Canavalia*, *Crotalaria*, *lablab* and *Mucuna*, were intercropped with Maize (Longe 1variety) in the first season (short rains of 2000) on plots of 5m X 5m. The legumes were incorporated during land preparation for the second season, in their respective plots and planted with maize. Maize grain and stover yields were measured for each season and an economic analysis using partial budgeting and marginal rate of return tools performed to highlight the feasibility of the green manure technology in the farming system. Results showed a no significant response in the intercropping (first) and third (residual) seasons, but significant maize gain yield increase for *Crotalaria* and *Lablab* green manure after incorporating(second season) the legumes of 96.4 and 69.6 % respectively compared to the control plot. This was probably due to deep nutrient capture by the *Crotalaria* roots and recycling the nutrients through leaf fall. Economic analysis results indicated positive returns to both land and labour from using green manure technology and highest Marginal rate of return of 100.63% were obtained from using *Mucuna* compared to *Canavalia* green manure. Based on economic returns and ease of establishment, *Mucuna* and *Canavalia* green manures were recommended for farmers as low cost soil improving technology

Profitability analysis and linear programming to optimize the use of biomass transfer and improved fallow species for soil fertility improvement.

*P.N. Pali, B. Bashaasha, R. Delve, R. Miiro.
African Crop Science Journal (Submitted)*

Studies that have focussed on the economics of integrated soil fertility management technologies have predominantly used the partial budgeting and Economic Rate of Return (ERR) analytical tools, whilst studies that have used the linear programming (LP) technique have been restricted to the evaluation of perennial cropping systems including agroforestry. This paper uses a partial budget analysis and LP to determine the optimal combination of management practice and profitability of using organic and inorganic soil improvement options. The incorporation of 100% or 50% of the above-ground biomass of improved fallow (IF) species *Mucuna pruriens* and *Canavalia ensiformis* and the biomass transfer (BT) species *Tithonia diversifolia* are the focal soil improvement practices (SIP) considered in this study. All SIP were more profitable than farmers existing practice, with BT being more profitable than IF, especially when BT was used in combination with inorganic N fertilizers. For IF the optimal SIP was found 50% *Mucuna* and 100% *Mucuna* application. Under the optimal solution 0.81 ha, 218.1 labour days and an investment of 327,150 Uganda Shillings would be required to obtain the optimal benefit of 188,867 Uganda Shillings over three cropping seasons would require For BT the application of 0.91 t ha⁻¹ of tithonia with 30 kg N ha⁻¹ would produce the highest net benefits of 445,744 Uganda shillings ha⁻¹, with a 16% lower optimal net benefit solution of 372,069 Uganda Shillings, on 0.83ha, using 105 labour days. The IF and BT options considered were all profitable and the production objectives and constraints of smallholder farmers is the only constraint to their adoption.

Activity 4.4 Decision tools for improved soil, nutrient, and water management developed and disseminated.

Published work

Organic resource management in sub-Saharan Africa: validation of a residue quality-driven decision support system

Bernard Vanlauwe¹, Cheryl A Palm¹, Herbert K Murwira¹ and Roel Merckx²

¹*Tropical Soil Biology and Fertility Programme, UN Gigiri, PO Box 30592, Nairobi, Kenya*

²*Laboratory of Soil Fertility and Soil Biology, Faculty of Agricultural and Applied Biological Sciences, Kasteelpark Arenberg 20, 3001 Heverlee, Belgium*
Agonomie (in Press)

A conceptual Decision Support System (DSS) for organic N management was developed based on information on residue quality – N-mineralization relationships. The current paper aims at validating the DSS using data obtained in sub-Saharan Africa on biomass transfer systems with maize. The percentage fertilizer equivalency (%FE) values of the organic resources increased linearly with their N content above a minimum of 2.3% N. For resources with high polyphenol contents, the slope of the regression decreased and the critical N content increased to 2.8%. For manures, no clear relationship between their %FE and quality was observed. Medium quality materials are to be applied together with mineral N. Several cases are discussed in which added benefits as a result of positive interactions between medium quality organic resources and mineral N were generated. Finally, thought is given on the information needed to turn the DSS from a concept into a useful soil management tool.

Although the data obtained largely support the concepts outlined in the DSS for organic N management, the reality on the field is such that the availability of high quality, fertilizer-like organic materials is very limited. Therefore, the arms dealing with medium to low quality organic resources are likely to be most relevant for real cropping systems. Such organic resources are recommended to be applied in combination with mineral fertilizer, and when doing so, added benefits do occur, although their mechanistic basis if most of the time not clearly understood. The relevance of such potential added benefits needs to be assessed for various biophysical environments and crops. In conditions where it is difficult to assess these potential benefits, assuming additive effects is usually good enough as a first approach as negative interactions are not commonly observed. Finally, generation of the needed knowledge will by itself not change the way farmers are managing their organic and mineral resources. This knowledge needs to be condensed in tools adapted to the clients targeted.

Using decision guides on manure use to bridge the gap between researchers and farmers.

Herbert K. Murwira^{}, Killian Mutiro and Pauline P. Chivenge*

Tropical Soil Biology and Fertility Program (TSBF Zimbabwe), c/o Faculty of Agriculture, University of Zimbabwe, P.O.Box MP228, Mt Pleasant, Harare, Zimbabwe.

Submitted to Agriculture and Human Values

A lot of work has been done to assess the value of manure as a plant nutrient source, characterize its quality, and on ways of improving its effectiveness through better storage or integrated use with inorganic fertilizers. While the knowledge gained on manure use has been immense; the information has hardly been translated into a useable form for farmers and extension. There are no effective messages that research and extension has passed on to farmers. There is a growing need to develop communication strategies that could effectively link farm practice with research results and ultimately bring about a positive change in the way farmers manage resources available to them.

This paper presents some decision guides developed for manure use based on both researchers' understanding and farmer perceptions. The decision guides have been field tested and developed further following discussions held with farmers. The usefulness of the decision guides as communication tools to enhance uptake of soil fertility management options is discussed.

Critical among issues raised in this paper is to continue testing the decision guides and ensure that they are robust and applicable (but not necessarily) to a wide range of environments without losing the context of farmer circumstances. The question of validation should be left to farmers while the main role of the scientist should be that of facilitating this process of validation. Validating decision trees should not be viewed more in terms of going out in the field to prove a scientific point, but rather in terms of enabling farmers to test our scientific models. In order for farmers to validate decision trees, they must understand the basic scientific principles from which scientists derived them, and this can only be done through a process of researcher farmer dialogue and mutual learning. By the same token the joint learning process should also enable scientists to refine and adjust their scientific models by closely observing how and why different farmers are making their choices.

Long-term soil organic carbon dynamics in a sub-humid tropical climate: ^{13}C data and modeling with RothC

J. Diels^{1,*}, B. Vanlauwe^{1,2}, M.K. Van der Meersch^{3,4}, N. Sanginga^{1,2}, R. Merckx³

¹IITA, Ibadan, Nigeria Tropical Soil Biology and Fertility Institute of CIAT, Nairobi, Kenya³Laboratory for Soil and Water Management, Faculty of Agricultural and Applied Biological Sciences, K.U.Leuven, Belgium

Information on long-term soil organic matter (SOM) dynamics in the tropics is scanty and this hampers validation of SOM models for such conditions. We observed SOM content changes in a 16-year continuously-cropped agroforestry experiment in Ibadan, southwestern Nigeria. The objectives were to quantify the effect of the cropping system and fertilizer additions on SOM contents, to investigate if ^{13}C abundance measurements could provide useful information in such complex system involving mixtures of C_3 and C_4 plant species, and to use the experimental data for testing the RothC soil organic carbon (SOC) model. It was found that two alley cropping systems, one with *Leucaena leucocephala* and one with *Senna siamea* hedgerows, sequestered an additional 5.0 Mg C ha^{-1} in the 15-cm topsoil after 11 years compared to the control treatment without trees. After 16 years, 5.2 Mg C ha^{-1} was sequestered. The addition of NPK fertilizer had little effect on the quantities of plant residues returned to the soil, and there was no evidence that the fertilizer affected the rate of SOC decomposition. The fact that both C_3 and C_4 plants returned organic matter to the soil in all cropping systems, but in contrasting proportions, led to clear contrasts in the ^{13}C abundance in the topsoil SOM. This ^{13}C information, together with the measured SOC contents, was used to test the RothC model and led to the following findings:

1. Compared to the control treatment with continuous maize/cowpea cropping without legume tree hedgerows, the two continuously cropped alley cropping (AC) systems (*Leucaena* and *Senna*) sequestered an additional 5.0 Mg C ha^{-1} in the 2300 Mg ha^{-1} equivalent soil mass in 11 years, and 5.2 Mg C ha^{-1} in 16 years.
2. The addition of mineral fertilizer (NPK) had little effect on the quantities of plant residues returned to the soil (sum of weeds, crop residues and tree prunings), and there was no evidence that the fertilizer affected the rate of SOC decomposition.
3. The ^{13}C natural abundance technique yielded useful information to test SOM models in a complex cropping system, in which both C_3 and C_4 plants were intercropped/rotated, and contrasts in the ^{13}C of the SOC resulted from the fact that

the relative OM contribution of the C₃ and C₄ components differed between the treatments compared.

4. The fact that we had to double the decomposition rate constants of the RothC26.3 model in order to reproduce the observed contrasts in SOC contents and ¹³C abundance between the AC systems and the control without trees indicated that SOC decomposition in this experiment was very fast. Possible reasons for this are (1) that the pruning materials from the legume trees and/or the extra rhizodeposition from the tree roots in the AC treatments accelerated the decomposition of the SOC present at the start of the experiment (true C-priming), and (2) that the physical protection of microbial biomass and metabolites by the clay fraction in the sandy top soil, in which clay minerals are mainly of the 1:1 type, was lower than assumed by the model.

Completed work

Modelling nitrogen mineralization from organic sources: representing quality aspects by varying C:N ratios of sub-pools

M E Probert^a, R J Delve^b, S K Kiman^c and J P Dimes^d

^a CSIRO Sustainable Ecosystems, Queensland Australia ^b Tropical Soil Biology and Fertility Institute of International Centre for Tropical Agriculture, Kampala, Uganda ^c Kenya Agricultural Research Institute, Muguga, Nairobi, Kenya

^d International Crops Research Institute for Semi-Arid Tropics, Bulawayo, Zimbabwe.

The mineralization/immobilization of nitrogen when organic sources are added to soil is represented in many simulation models as the outcome of decomposition of the added material and synthesis of soil organic matter. These models are able to capture the pattern of N release that is attributable to the N concentration of plant materials, or more generally the C:N ratio of the organic input. However the models are unable to simulate the more complex pattern of N release that has been reported for some animal manures, notably materials that exhibit initial immobilization of N even when the C:N of the material suggests it should mineralise N. The APSIM SoilN module was modified so that the three pools that constitute added organic matter could be specified in terms of both the fraction of carbon in each pool and also their C:N ratios (previously it has been assumed that all pools have the same C:N ratio). It is shown that the revised model is better able to simulate the general patterns on N mineralised that has been reported for various organic sources. By associating the model parameters with measured properties (the pool that decomposes most rapidly equates with water-soluble C and N; the pool that decomposes slowest equates with lignin-C) the model performed better than the unmodified model in simulating the N mineralization from a range of feeds and faecal materials measured in an incubation experiment.

Linking farmer criteria and laboratory indices for on-farm prediction of manure quality in smallholder farming areas of Zimbabwe.

L. Rusinamhodzi, H.K. Murwira and K. Mutiro

Tropical Soil Biology and Fertility Institute of CIAT, , Harare, Zimbabwe.

This study evaluated the relationship between farmer criteria and laboratory indices of manure quality. The methodology involved carrying out Participatory Rural Appraisals in Murewa, Shurugwi and Tsholotsho smallholder-farming areas of Zimbabwe. Farmers were asked to bring manure samples, identify manure quality indicators and categories, and assign the manure into the identified quality categories. An incubation study was carried out using manure from the quality categories identified by farmers at a rate equivalent to 100kg N ha⁻¹ in a sandy soil to determine CO₂ evolution and the N mineralization patterns.

Three quality categories were identified in Shurugwi and Tsholotsho while farmers in Murewa came up with four categories. The consistency of categorizations was validated by a positive rs value of 0.711 for the ranking exercise in Shurugwi and Tsholotsho and also using scientific criteria of N and C contents and nutrient release characteristics. Effects of quality category were found to be significant (p<0.05) for both N release and CO₂ evolution. Nitrogen release decreased with decrease in quality while rate constraints for C mineralization increased with decrease in quality reflecting differences in C/N ratio and stabilization of C in higher quality manure. It was concluded that farmer criteria of manure quality were consistent across areas, and are related to laboratory indices and hence can be used for evaluating manure quality in the field. More work needs to be done to translate some of the farmer manure quality criteria into quantitative tools that can be used consistently in the field.

Simulation modelling and participatory research: closing the gap between research and management in smallholder farming systems.

S. Twomlow and J. Dimes (ICRISAT), Z. Shamudzarira (CIMMYT), R.J. Delve (TSBF-CIAT) and P. Thornton (ILRI)

A paper was presented at the Forum Agriculture Research in Africa (FARA)

Participatory research (PR) is an approach that attempts to bridge the gap between the professional researcher and real world management of agricultural production systems, particularly in smallholder farming systems. While the successes (and shortcomings) of on-farm PR experiences and approaches have been widely documented, an overlooked issue is the site and season specificity of on-farm experiments and the limited interpretation and learning possible from such experiments due to monitoring limitations. These are the same constraints that on-station experimentation face and which crop simulation modelling has long been touted to overcome. However, for on-farm experimentation an important distinction exists that poses a difficult question: 'Do research simulation models have the capability and flexibility to be an effective analytical learning tool in the case of on-farm research where so many factors (cropping system, soil, climate, management, monitoring) are highly variable and generally uncontrolled?'

Recent and on-going collaborative efforts between ICRISAT, CIMMYT, ILRI, TSBF-CIAT and local NARES partners in eastern and southern Africa, have developed the crop (legume, weed, manure and phosphorus) and livestock simulation capability and trade-off analysis tools to a point where we now have tools that are relevant to natural resource management in smallholder farming systems. The linking logics workshops with farmer involvement provided first hand experiences that this is true, that participatory on-farm research approaches and systems simulation modelling can be integrated to develop improved soil fertility management options with farmers. Farmers develop crop and livestock management scenarios with researchers for simulation modelling to evaluate trade-offs and economic returns and have then evaluated these alternative options on-farm through farmer research groups and farmer field schools.

This approach assesses which scenario most efficiently manages the nitrogen and phosphorus nutrient sources available to a household for crop and livestock production. Alternative combinations of organic and inorganic nutrient sources can be evaluated in terms of crop or livestock production gains and the most economic combinations identified. This evaluation includes both the short and longer-term economic and environmental benefits. From the social and economic viewpoint, organic resources can be identified that could substitute for mineral fertilizers in areas where fertilizers are not affordable. Management strategies can be identified for using or combining scarce nutrient sources for attaining desired crop yields. From an environmental aspect, management practices could be identified that results in fewer nutrient losses and would rebuild or maintain the soil resource base.

This approach has also been used to investigate specific farm-level scenarios and trade-offs, for example:

- ?? Land allocation – which crops to which land
- ?? Efficiency of fertilizer use – when to apply and how much
- ?? Labour constraints – when to weed, when to apply manures
- ?? Investment options: capital allocation - livestock versus crop enterprises, labour allocation - farm and non-farm
- ?? Appropriate use of crop residues in mixed systems

On-Going Future Work

Decision Support Systems for Integrated Soil Fertility Management

J.J. Ramisch and M. Misiko
TSBF-CIAT

Adaptation by farmers of research-designed technologies is crucial for increasing the relevance and therefore adoption of technologies. Adaptive research has to be linked to increasing the capacity of service providers and farmers to disseminate this new information and to ensure effective information flow between research and extension.

Since May of 2002, four interactive participatory events have occurred at a TSBF-farmer demonstration plot in Emuhaya, W. Kenya. Efforts have been made to describe and explain to a wider audience (local farmers) TSBF's process of soil fertility research in W. Kenya. Key among the explanations were that TSBF in conjunction with local farmers and other research institutions have identified soil infertility and related problems as major and are researching on alternative or/and potential solutions.

Some of the technologies that have been researched are being illustrated on the demonstration plot in Emuhaya. These activities include i) improved fallows ii) efficient recycling of residues iii) use of inorganic and organic fertilisers iv) traditional practices like natural fallows and use of indigenous plants among other technologies. On July 31, 2002 farmers and researchers held an evaluative field day and discussions at the demonstration site. Farmers expressed the main areas of strength and pointed out improvements that were needed. On August 16, 2002, farmers and TSBF staff harvested maize on the demonstration plot in Emuhaya. On August 22, 2002 a community discussion was held involving different types of farmers and TSBF staff to assess achievements, limitations and lessons achieved from the activity. On the former day, a pre-harvest evaluation was done, and also ranking of the different plots under different treatments. On the later day, in-depth deliberations were held about the plot and way forward. This was a furtherance of preliminary discussions that had been held during different stages of the demonstration.

The technologies that were demonstrated on the plot include i) efficient recycling of crop residues ii) use of inorganic and organic fertilisers and their iii) different combinations iv) biomass transfer and use of legume trees. Also tackled, and not demonstrated, include use of indigenous plants as manures.

There was a step-wise pre-harvest review of plots under different treatments by farmers and TSBF staff. Many of the attendants had visited the plot before and many had participated in various or different activities at the site and were already acquainted with the plots. A summary of all activities that had been done on and at the demonstration plot was given and the plots were briefly described; the different treatments included:

	Low quality (maize stover)	Intermediate quality (FYM)	High quality + polyphenols (<i>Calliandra calothyrsus</i>)	High quality (<i>Tithonia diversifolia</i>)	Control plot (no organic)
	?	?	?	?	?
No N or P ↗					
+ Urea only ↗					
+ Urea, +TSP ↗					

A rapid pre-harvest assessment of plots was held; first, amongst the first five (with organic inputs only); second, between plots with organic inputs alone and those with different inorganic fertilisers added; and three, amongst those with inorganic fertilisers. This was done to illustrate nutrient contributions of selected inputs.

All maize plants on every plot were counted. After getting the sum of maize on every subdivision, farmers systematically harvested the crop, starting with the control and weighing both stover and maize. Various observations were made, and notes on the following taken by farmers: Differences in dryness, weight, appearance; Effect of striga, other weeds and pests.

Most maize had been twisted, lying on the ground due to a past storm. Low harvest was also blamed on late planting and a long dry spell in June. Farmers said that under normal local circumstances one would likely get some harvest, however small, and not to completely miss out even when no input is applied as happened under the control plot.

Variability within plots: The soil type on the plot is called *ingusi*. *Ingusi* is yellowish brown to dark brown, clayey soils. It occurs commonly in Emuhaya according to the soil study that was done in February 2002. Striga was very prevalent on plots with high fertility, especially where TSP was applied. This contributed to low harvests on those plots. It was clarified that inorganic fertilisers do not 'bring' or increase striga weed as expressed by few farmers during the discussion. Rather, fertility conditions needed by striga were created on those spots where TSP was used.

Ranking of treatments: Plots were ranked on the basis of: Green leaves – before drying; Thick and long leaves; Height of stalks relative to seed type (hybrid etc.); Bigness of maize, and cobs; Germination rate; Rate of growth, especially after germination, is determinant; Number of cobs on every plant; Number of lines of maize on every cob, especially important in selection of planting seed [12-14 lines (hybrid 513), 16 lines or even more (pioneer usually has one cob with large seeds). Number of lines is relative to type of seed. Also size of every seed matters. Small seeds are good for roasting]; Weight of maize, through estimation by hand and observation.

Farmers used these criteria to rank the various plots. The table below shows results of the ranking. The Table also displays results of previous ranking that had been done and documented two weeks before harvest.

Table 10: Rank of Organic Resources that were used

Rank	1	2	3	4
Pre-harvest	FYM	<i>Tithonia</i>	<i>Calliandra</i>	Stover
Post harvest	<i>Tithonia</i>	FYM	<i>Calliandra</i>	Stover

Table 10 shows a shift in ranks, between FYM and *Tithonia*. This change came as a result of weighing; maize on *Tithonia* plot was heavier than that on FYM plot. During preliminary ranking, FYM was seen to have had a more positive role in the context of the demonstration trial. Then, the overall aspect was the size and not weight of maize cobs. On the basis of this, FYM had *performed* better because it would result in higher yield. The order of ranks was respectively similar for plots with organic resources listed above with TSP alone, and TSP and DAP added. It was easier for farmers to tell differences between segments with organic resources only, unlike comparison between those with inorganic fertilisers. Farmers therefore deduced that certain mineral components (i.e.: P) can only be adequately sourced from inorganic fertilisers. P had been unknown to majority of farmers before prior demonstration events were held.

Lessons and conclusions:

- ?? Good harvest (quality and quantity) depends on:
 - Availability of rain, type of rain
 - Timing of planting (recommend that TSBF plant at same time as the majority of farmers to enable them to better compare with and borrow ideas from trial site).
 - Type of soil (recommend that TSBF locate trial sites on each of the major local soil types).
- ?? Appropriate use of high quality resources like Tithonia was seen to have a bigger potential locally. However, labour to harvest Tithonia was highlighted as a constraint.
- ?? Use of stover as fertiliser was seen as less promising option. Stover is used as fodder and as fuel material, and because it is usually available in small quantities, abandoning it in the field is not very feasible. Other ways to use it more productively should be devised, or to feed it to livestock and to use the resultant dung as FYM.
- ?? The site allowed farmers to better learn how to tell whether plant material is good manure e.g. softness, quick to rot, easy to tear, bitter taste. Masatsi, mireembe che sisungu etc.

Observations:

- ?? There is lack of cash to use available technologies, especially because of lack of P in most local soils and the need to buy P-containing fertilisers.
- ?? Farmers' comments that the demonstration plots should be 'large' reflect concerns that local farms display considerable variability in soil quality even over small distances and that it is difficult to extrapolate performance from 3 x 3 m plots. This variability results from concentration of resources on certain sections of the plot – driven by labour shortage, on the basis of what section is more promising. These sites tend to be where there is more fertility and where farmers tend to plant first. There are certain sections (especially near the house) where organic materials are dumped regularly.
- ?? There was much interest in doing more demonstrations; with the current awareness, more farmers are likely to attend and learn from the process.
- ?? Disease and funerals affected attendance in field days at the plot

Activity 4.5 Improved understanding of adoption and adaptation processes, including identification of policy constraints and responses, developed.

Published work

Integrated soil fertility management: evidence on adoption and impact in African smallholder agriculture

Frank Place¹, Christopher B. Barrett², H. Ade Freeman³, Joshua J. Ramisch⁴ and Bernard Vanlauwe⁴

¹ICRAF, Nairobi, Kenya; ²Cornell University, USA, ³ICRISAT, Kenya, ⁴TSBF, Nairobi, Kenya

This paper reviews current organic nutrient management practices and their integration with mineral fertilizers in Sub-Saharan Africa with a view to understanding the potential impacts on a range of input markets. A number of different organic nutrient management practices have been found to be technically and financially beneficial, but they differ considerably as to their effectiveness and resource requirements. Review of African smallholder experiences with integrated soil fertility management practices finds growing use, both indigenously and through participation in agricultural projects. Patterns of use vary considerably across heterogeneous agroecological conditions, communities and

households. The potential for integrated soil fertility management to expand markets for organic inputs, labor, credit, and fertilizer is explored. We hypothesize that markets for organic markets are hampered by inherent constraints such as bulkiness and effects on fertilizer markets are conceivably important, although no good empirical evidence yet exists on these important points.

Integrated soil fertility management practices are thriving in agricultural research and development projects, as the use of organic inputs increases, both on a stand-alone basis and in conjunction with mineral fertilizers. Much of this initiative is due to farmer innovation and adaptation, often in response to macroeconomic and sectoral reforms that have driven up real fertilizer prices throughout the continent. Organic systems have been found to complement fertilizers in many ways, both in a biophysical sense (enhancing soil fertility beyond nutrients alone) and in a socio-economic sense (requiring different types of household resources). Some organic systems are performing well on their own and in integrated systems, as measured by yields and profits. Like mineral fertilizer, there appears to be more interest in, and impact from, the use of organics and integrated systems on higher value crops. Because of their low cash requirements, some organic-based systems are reaching poorer households that otherwise are scarcely using any fertilizer.

But there are limits to the amounts of organics that can be produced on-farm, particularly where labor constraints bind. There remains insufficient evidence as to whether increased use of organic inputs are spurring increased overall use of nutrient inputs. While biophysical research in integrated soil fertility management is progressing rapidly, more research is needed on farmers' practices, including their innovations and integration of individual components. There is also an urgent need to extend both bodies of research to higher value crops and whole farm analyses.

Markets for organic biomass are limited mainly due to the inherent characteristic of relatively low quality of nutrients per weight resulting in bulkiness. Markets have developed for animal manure, especially quasi-contractual arrangements between owners of free grazing cattle and stover owners. Markets for green manure do not exist to any significant degree. Markets for green manure germplasm have developed in response to demand from projects and from farmers when the plant yields feed or food product in addition to soil nutrient replenishment.

In order to ultimately contribute to increased productivity through improved soil fertility management, a few steps can be highlighted. First, there is still need to develop more attractive options, components and integrated strategies for small farmers of which improved germplasm is an integral part. This requires tighter linkage and feedback between strategic and adaptive research activities. Farmers are moving quickly in experimentation and the researcher community must be more active in monitoring this work. This will require more partnerships among farmers, extension, development projects, and researchers to bring wider development efforts into the knowledge base of researcher.

Second, because ISFM practices are knowledge intensive, a major challenge is to identify scaling up processes that are both effective and not too costly in terms of information provision and technical support. It will be especially challenging to overcome the many bottlenecks of information flow across different organizations, from organizations to communities, between communities, and between farmers within communities. There is a need to develop incentive systems that reward improved flows of information. Rewards to communities for their efforts similar to the Landcare system in the Philippines or the Presidential award in Kenya are worth exploring, as are ways of utilizing existing rural collective action (e.g. community-based organizations) to facilitate information flow.

Third, there must be major efforts to make agricultural commercialization more attractive to small farmers. Low rates of market participation are leading correlates of both poverty and the absence of sustainable agricultural intensification through increased investment in the land (Barrett and Carter 1999, Reardon et al. 1999). Increasing commercialization requires improving access to input markets, including for working capital (e.g., credit, savings) needed to purchase mineral fertilizer, organic inputs and seed and to hire labor, perhaps especially for women, who are key soil fertility managers in much of the continent. This is relatively easier in favorable agricultural zones where investment in market infrastructure can have a big impact. Indeed private, commercial interests sometimes undertake such investment voluntarily in support of lucrative contract farming schemes. Stimulating greater market participation is trickier in drier areas, although research from South Asia suggests that the marginal returns, in terms of both poverty reduction and production value, are highest for road infrastructure investments in low potential rainfed areas (Hazell and Fan 2001). Roads are important, but the organization of marketing and finance demand attention as well, building on local self-help groups to help resolve coordination and contract enforcement problems bedeviling much commerce in rural Africa today.

Rapid growth in experimentation with organic soil inputs has fuelled the emergence of an extremely promising integrated soil fertility management paradigm that is just beginning to be evaluated carefully. A wide variety of studies report widespread experimentation with ISFM across all agroecological zones in Africa, including by many farmers who had not been using mineral fertilizers. Nonetheless, problems of market access, and household-level availability of land, labor and working capital continue to limit the extent of adoption of ISFM among poorer small farmers. One finds pockets of active and effective users surrounded by vast areas of non-use.

Much remains to be done, both in terms of research and development practice, to establish how best to employ the emergent ISFM paradigm to overcome or increase Africa's miniscule rates of mineral fertilizer application and stimulate agricultural productivity growth. The task is made all the more pressing by economic policy reforms that have caused a sharp drop in fertilizer use by small farmers in many areas. The core challenges to scaling up limited successes with ISFM to date appear threefold: improving integration between strategic and adaptive research, accelerating and expanding the flow of information among farmers, and increasing agricultural commercialization through improved market access, especially in lower potential rainfed regions.

Farmer participatory evaluation of legume cover crop and biomass transfer technologies for soil fertility improvement using farmer criteria, preference ranking and logit regression analysis

Nyende, P. and Delve, R. J

Tropical Soil Biology and Fertility Institute of International Centre for Tropical Agriculture, PO Box 6247, Kampala, Uganda

Experimental Agriculture (Submitted)

Six species, *Canavalia ensiformis*, *Crotalaria grahamiana*, *Dolichos lablab*, *Mucuna pruriens*, *Tephrosia vogellii* and *Tithonia diversifolia* were evaluated as potential species for soil fertility replenishment in on-farm adaptive trials, farm visits and field days in Tororo District, eastern Uganda. Farmers used multiple criteria for assessing and selecting potential species that fitted within their production systems and production objectives. Farmers also adapted the technologies to allow for local opportunities and constraints. A preference ranking and logit regression analysis of probabilities of acceptance of the species conducted in 19 farmer groups showed that *Tithonia* had high, *Mucuna* and *Crotalaria* intermediate and *Lablab* and *Tephrosia* low probabilities of being accepted or adopted. The evaluations showed that whilst technologies need to be adapted, a single

use technology had little chance of large-scale adoption. This paper highlights adaptations/innovations by farmers and opportunities for participatory action research targeting farmers' production objectives.

Whilst technologies exist that increase soil productivity and are profitable for farmers there are many other factors preventing them from adopting the technology. Following the land for example, is not possible where small land sizes or high population densities exist and where seed supply for these legume cover crops is not good. In eastern Uganda, where the population pressure is much lower and where natural fallowing is still part of the farming system, the opportunities for improved fallowing or biomass transfer is much higher. Even so, issues of increased labour requirements for incorporation or collection of biomass are commonly cited by farmers during evaluations.

In this dynamic environment farmers assess the different management options available to them and adapt them to fit their own circumstances and production objectives. For example, growing *Tithonia* on-farm in available niches (around the field boundaries, for example) is one way of over-coming shortage of *Tithonia* and reducing the labour that would be needed if collecting the biomass from off-farm locations. Innovations in using these legume cover crop and biomass transfer species are very common. This work has identified many adaptations/innovations by farmers not just for increasing crop production but also for pest and weed control, consumption of the seeds and for livestock feeding.

The criteria used for species selection and the farmers' innovations provide essential feedback to the participatory action research approach as they reflect the opportunities and constraints of the production systems of the farmers and raise many new areas of research, opportunities of evaluation of new technologies and species and the better targeting of existing information.

Contending with Complexity: The Role of Evaluation in successful INRM

Boru Douthwaite¹, Robert Delve², Javier Ekboir³ and Steve Twomlow⁴

¹ Adoption and Impact Specialist, IITA, Ibadan, Nigeria, ² Soil Fertility Management, TSBF Institute of CIAT, Kampala, Uganda, ³ Economist, CIMMYT, Mexico ⁴ Global Theme Leader Water, Soil and Agrobiodiversity for Ecosystem Health, ICRISAT, Bulawayo, Zimbabwe.

Paper presented at the INRM Workshop, Aleppo, Syria, 16-19th September, 2002

In contrast to reductionist approaches, Integrated Natural Resource Management (INRM) takes a holistic perspective that sees technology change as a complex social process, in which networks of agents that include, among other members, farmers, researchers, input suppliers, NGOs, extension agents and other government agencies generate and diffuse technologies. The technologies, networks and individual agents coevolve in response to emerging technical, social and economic challenges and opportunities. These changes affect adoption rates and who benefits and loses. More importantly, early identification of the forces that shape the evolution path of the technology and the network is essential for successful introduction and adoption of a new technology. Hence, it follows that rural development is an immensely complex process, with a high degree of non-linearity. Current 'best practice' economic evaluation methods commonly used in the CGIAR system, which attempt to establish a linear link between a project's outputs and regional or economy-wide impacts, struggle in this complexity. Indeed, such economic Impact Assessment (IA) is only valid if: 1) the causal link dominates from start of research to the measurement of impact; 2) there are no other factors affecting adoption and impact; 3) chance has no influence; and 4) inputs and impacts can be measured to an acceptable degree of accuracy. In practice replacement plant breeding is one of the very few CGIAR activities where these assumptions are likely to hold. A second shortcoming of economic IA is that it focuses largely on *ex-ante* and/or *ex-post* IA, but has little to offer in the area of

monitoring and evaluation (M&E), despite M&E being identified as important in ensuring research projects actually achieve impact.

In this paper we review three case studies of M&E being conducted by three CGIAR centres in Africa. The case studies are: 1) Farmer participatory evaluation of legume cover crop and biomass transfer technologies for soil fertility improvement in eastern Uganda; 2) Impact pathway evaluation of integrated *Striga* control in Northern Nigeria; and 3) monitoring and evaluation of the dissemination of crop management options in Zimbabwe and Malawi. Although carried out independently, all three case studies focus on identifying the contributions of individual agents (e.g., farmers, researchers or input suppliers) to the adaptation and adoption of innovations, and the agents' motivations and perceptions that mould them. In each case study we examine the project, the creation of organisational capabilities and the changes that result from this understanding and conclude that participatory M&E has a vital role to play in helping projects respond early to farmers' evolving opportunities and needs. Finally, we argue that *ex-post* impact assessment should be based on the understanding of innovation processes developed during the M&E which shows which role each stakeholder played and why it made a difference, but without attempting to attribute a value to that contribution.

M&E has helped give the ISC project a much clearer impact focus through the process of defining the project's impact pathway. The M&E findings have redirected research efforts in a number of ways, including through the incorporation of farmer innovations in the recommended basket of options; the decision to carry out a partial budgeting exercise to bring farmers' and researchers' perceptions of the pros and cons of mixed versus sole cropping closer together; and by providing the understanding of adoption processes necessary to develop an effective ISC dissemination approach.

Completed work

Assessment of adoption potential of soil fertility improvement technologies in Chuka Division, Meru South, Kenya

Ruth Kangai Adiel¹, J.J. Ramisch

¹ *Kenyatta University, Kenya*

Declining soil fertility is a key problem faced by farmers in Eastern Kenya. The problem has been worsened by increased population growth and at the same time high demand for agricultural produce. To solve the problem land users are being encouraged to adopt soil fertility improvement technologies, which use locally available resources. In a demonstration trial at Kirege primary school Chuka division, a number of such soil fertility improvement technologies were demonstrated from which farmers were encouraged to voluntarily select and practice on their farms.

This study therefore set out to evaluate the extent to which farmers adopted and adapted the demonstrated technologies and also to identify the factors that influenced their adoption or non-adoption of these technologies. To do this a farmer follow-up study was carried out in Chuka division over a period of two cropping seasons. Data was collected using farm surveys, on-farm trials and visual records. The data was then subjected to logic regression and cost benefit analysis to determine important variables affecting adoption and the most profitable treatments of the new technology respectively.

The study found out that the use of inorganic fertilizer though preferred by most farmers was low. This was due to the high cost of the fertilizer. Most farmers practiced soil fertility improvement technologies involving the use of cattle manure, which was readily available, though in inadequate quantities to supply the required nutrients. Further, lack of access to

credit and inadequate extension services were identified as some of the critical issues limiting effective adoption of soil fertility improvement technologies. Eighty (80) farmers adopted the soil fertility improvement technologies during the short rains season 2001. During the subsequent two seasons, 163 and 206 farmers representing an increase of 99% and 150% above the initial adopters started practicing the proposed soil fertility improvement technologies. Technologies involving the use of *Tithonia diversifolia* and *Calliandra calothyrsus* alone or in combination with inorganic fertilizer were readily adopted due to the high yields obtained. During the first season of farmer follow-up, tithonia + half rate of inorganic fertilizer gave the highest net benefit of Kshs. 50133 per hectare followed by the full rate inorganic fertilizer treatment with a net benefit of Kshs. 48568. Fertilizer treatment had the highest benefit cost ratio (BCR) of 7.5. Sole manure treatment recorded the lowest net benefit Kshs. 4601 and hence the lowest BCR of 0.9. However during the second season manure plus half-inorganic fertilizer recorded the highest net benefit of Kshs. 41567 with a BCR of 3.7. Farmer practice involving no input had the lowest BCR of 0.2 with a net benefit of Kshs. 9853.

Constraints to the adoption of the proposed soil fertility improvement strategies were identified as inadequate labour, poor yields observed from some of the technologies at the demonstration trial, inadequate organic and inorganic resources and laxity due to fear of failure. Logistic analyses of the factors affecting adoption of soil fertility improvement technologies identified gender, farmer's occupation, land size and land under food production as major factors significantly affecting adoption of soil fertility improvement technologies in Kirege location, Chuka division. In conclusion there is need for the researchers to put in mind the factors that might affect adoption of a technology in order to have high adoption rates in any given area.

Activity 4.6 Improved understanding of scaling up and out processes for ISFM practices.

Published work

Four Obstacles to Taking Integrated Soil Fertility Management Research to Higher Scales

J.J. Ramisch [Chapter 16 in proceedings of CIAT AGM 2002]

This chapter takes integrated soil fertility management (ISFM) as an example of a knowledge-intensive system of technologies and innovations for managing natural resources. While researchers, farmers, and policymakers alike may express an interest in taking ISFM to "higher scales", the processes for achieving this scaling out or up are neither straightforward nor uncomplicated. It is argued here, using examples from the African experience of CIAT's Tropical Soils Biology and Fertility Program (TSBF), that taking ISFM to higher scales must contend with at least four potential obstacles. First, because ISFM addresses ecosystem properties and involves multiple stakeholders, transferring knowledge between scales must contend with and resolve the many potential clashes of expectations. Second, problems are inherent in the fact that the broader use of ISFM concepts requires a scaling up of knowledge itself, which is not the case with the spread of more simple technologies or goods. Third, the development of ISFM principles relies heavily on innovation and experimentation—indeed on creating opportunities and nurturing the good fortune of serendipity—to tailor generic management principles to diverse local conditions. Finally, there are obstacles related to managing the complexity of ISFM systems, from merely knowing what innovations have occurred and are worth reproducing to understanding and targeting interventions to different parts of the systems.

Output 5 – Research and training capacity of stakeholders enhanced

Output rationale

Milestones

1. Research and training capacity of stakeholders enhanced
2. Products of ISFM disseminated to partners and farmers
3. Policy briefs developed to promote ISFM

Activity 5.1 Strengthen networking on ISFM approaches

Completed work

The African Network for Soil Biology and Fertility: New Challenges and Opportunities

Bationo A., Kimetu J, Ikerra S, Kimani S, Mugendi D, Odendo M, Silver M, Swift M.J. and Sanginga N.

Soil fertility degradation has been described as the single most important biophysical constraint to food security in sub-Saharan Africa (SSA). Soil fertility decline is not just a problem of nutrient deficiency but also of 1) Inappropriate germplasm and cropping system design, 2) Interactions with pests and diseases, 3) The linkage between poverty and land degradation, 4) Often perverse national and global policies with respect to incentives, and 5) Institutional failures. Tackling soil fertility issues thus requires a long-term perspective and a holistic approach. The African Network for Soil Biology and Fertility (AfNet) of Tropical Soil Biology and Fertility institute of CIAT is devoted to overcoming this challenge. AfNet's ultimate goal is to strengthen and sustain stakeholder capacity to generate, share and apply soil fertility management knowledge and skills to contribute towards improved livelihoods of farming communities. This African-wide network has over 200 members from National Agricultural Research and Extension Services (NARES) and universities from various disciplines mainly soil science, social science and technology transfer. This paper highlights AfNet's main activities which include: Network field research activities, information and documentation, training and capacity building.

Coordinate research and developmental activities of the MIS consortium in Honduras, Nicaragua and Guatemala.

M. Ayarza (CIAT), M. Somarriba (UNA); L. Welchez (FAO) and S. Rivera (ESNACIFOR)

The MIS consortium was created in 1999 with the objective of generate, adapt and disseminate, options for the sustainable management of fragile soils in Central America. During these four years MIS partners have executed joint activities to collect information, generate and disseminate technology for the improved management of soil, water and nutrients in fragile soils of Honduras and Nicaragua. During the present year the Institute for Agricultural Technology, ICTA from Guatemala has joined formally to the consortium.

During the planning meeting conducted last Feb 2003. MIS partners decided to focus efforts of the consortium in three main topics: 1) dissemination of knowledge and information generated by the consortium; 2) strengthening linkages with other networks and consortiums (AfNet and CRSP) and; 3) development of Concept Notes and proposals to support the consortium in the next few years. Table 11 summarizes the main activities and outcomes of the consortium for 2003

Table 11. Activities and outcomes of the MIS consortium for 2003.

ACTIVITIES	RESPONSIBLES	OUTCOMES
Annual Planning meeting	Executive Comitee	Review and prioritization of activities. Several Concept Notes developed
Development and validation of indicators of water quality	S. Rivera, ESNACIFOR L. Garcia , CATIE	Technicians from NARS and NGO's of Honduras and Nicaragua trained in the use of water quality indicators .
Economic evaluation of soil losses	M. E. Baltodano, CIAT	Methodology improved
Validation of NuMaSS	Jot Smyth, NCSU	Several field experiments in progress to validate recommendations of NuMaSS. Formation of a network of soil-plant laboratories among MIS partners in Honduras, Nicaragua and Guatemala.
Hydrological function of watersheds	S. Rivera, ESNACIFOR; M. Somarriba, UNA L. Caballero, ZAMORANO	Training of students and personnel from the three institutions in the use of the SWAT model

Dissemination of knowledge

Activities related to dissemination of knowledge included the training of students and technicians from CATIE, ESNACIFOR, UNA and ZAMORANO in the use of benthic macrofauna as a biological indicator of water quality to complement standard physico-chemical parameters. On the other hand, personnel from the same institutions were trained in the use of the SWAT model to assess water dynamics in several watersheds located in the reference sites of the consortium. The methodology on economical evaluation of soil erosion was presented during a meeting in Bogota, Colombia.

Development of Concept Notes and Proposals.

The MIS consortium is a key partner in the proposal "Improving crop water productivity, food security and resource quality in the sub-humid tropics: Unraveling the mysteries of the Quesungual slash and mulch agroforestry system (QSMAS)". This proposal was submitted to the C.P on water and food.

Another proposal was developed in Estelí, Nicaragua a follow up meeting after the planning meeting. This proposal is still under discussion and review. It will be submitted to donors before the end of the year.

Activity 5.2 Develop strategic partnerships in capacity building to empower stakeholders.

Completed work

AfNET training and capacity building

Seven AfNet members from West Africa attended a training course on monitoring nutrient flows and evaluating farm economic performance in tropical farming systems (NUTMON) organized by the African Soil Biology and Fertility Network (AfNet) in Nairobi, Kenya (14th April – 25th April, 2003).

In order to build capacity for AfNet members, AfNet scientists in different countries of Africa including, Burkina Faso, Senegal, Mali, Ghana, Nigeria, and Kenya were invited for a two weeks workshop in Nairobi to expose them to a nutrient monitoring methodology developed by Wageningen University and Research Center in The Netherlands.

The workshop goal was to develop the capacity of The African Network for Soil Biology and Fertility (AfNet) member scientists understand on-farm nutrient monitoring methodologies as the basis of determining farm nutrient budgets and balances.

Participatory Approaches to Research and Scaling Up: An African Soil Biology and Fertility Network (AfNet) Training Workshop

Chitsike, C., Sanginga, P., Ramisch, J., Delve, R., Kaganzi, E.

The first ever training of AFNET scientists in farmer participatory research (FPR) methods and scaling up (SU) was held in Arusha, Tanzania between 28 September and 10 October. Thirty AFNET scientists from East, Southern, and West Africa took part in the two-week training, which covered key concepts and tools for applying farmer participatory methods to their soil science research. Separate field sessions in each week, in participatory diagnosis and technology evaluation, applied the learning directly in practical settings with Tanzanian farmers.

The course facilitators were from CIAT-Africa's "Enabling Rural Innovation" Team and the Tropical Soil Biology and Fertility Institute (CIAT-TSBF).

Topics covered included:

- ?? Key elements of Farmer Participatory Research and Scaling Up
- ?? Essential communication & facilitation skills
- ?? Tools for Participatory Diagnosis
- ?? Linking ISFM to market opportunities
- ?? Managing social processes & group dynamics
- ?? Selecting and working with farmer research groups
- ?? Community-based ISFM experimentation
- ?? Technology evaluation
- ?? Scaling up ISFM

Participants agreed that FPR and SU approaches offered great potential for increasing the relevance and impact of their research on integrated soil fertility management. They developed action plans for implementing these approaches in the current work, and will also use their new skills and attitudes to influence AFNET's future research and planning directions.

WORKSHOP GOAL

To develop the capacity of The African Network for Soil Biology and fertility (AFNET) member scientists as far as their knowledge and skill level of Farmer Participatory Research (FPR) & Scaling Up (SU) approaches are concerned and to enhance their ability to apply the FPR & SU approaches in their Research and Development work.

OBJECTIVES

- ? To sensitise and familiarise AFNET Scientists on the concepts and practice of Farmer Participatory Research (FPR) and Scaling Up (SU).
- ? To build capacity through provision of knowledge and enhancing skill levels of the network member scientists in FPR approaches.
- ? To build and support active AFNET teams in East, West, and Southern Africa to improve soil management, food production and incomes for poor farmers by bringing together many elements at the level of farmers as decision makers.

Participants agreed to include a further objective, namely:

- ? To generate ideas on how to follow up FPR and SU approaches within AFNET, particularly within the proposed sub-Saharan Africa Challenge Programme.

MIS-CRSP

M. Ayarza and J. Smyth (NCSU)

The goal of this collaborative effort is to support the adoption of NuMaSS-based knowledge via networks of on-going programs throughout Latin America with potential to benefit from the improved access to information on N, P and /or soil acidity management.

During the initial visit to MIS on August 2002, Alfredo Alvarado (Univ of Costa Rica), Deanna Osmond and Jot Smyth (N.C State Univ) presented a three –day workshop on the NuMaSS software and visited CIAT reference sites in Honduras and Nicaragua. Three major themes were identified during the meeting:

1. Incorporation of regional data into the NuMaSS data base-this includes the extensive soil pedón database CIAT and collaborators developed in Honduras, regional legume cover crop coefficients, major climatic ecosystems in Central America and images of nutrient deficiency symptoms.
2. Correlation of soil/plant analytical methods and results among laboratories to improve fertilizer recommendation. There about eight laboratories distributed among MIS-member-institutions in Honduras and Nicaragua.
3. NuMaSS field testing and validation-testing and comparing existing field trial data existing predictive criteria or validate/adjust criteria used by NuMaSS.

Activity 5.3 Improve dissemination of knowledge on ISFM.

AfNET information and documentation.

A first book on “Soil Fertility Management in Africa: A regional Perspective” written and edited by Afnet members was distributed to all AfNet members in West and Central Africa Books



Soil Fertility Management in Africa: A regional Perspective (2003)

Edited by: *Gichuru MP, Bationo A, Bekunda MA, Goma HC, Mafongoya PL, Mugendi DN, Murwira HM, Nandwa SM, Nyathi P and Swift MJ*

The book incorporates (a) a thematic thrust towards an integrated approach to soil fertility management - combining biological, physical and socio-economic scientific research with farmer's needs and opportunities, and (b) agro ecological reviews where the focus is to apply the lessons from the integrated analysis to the particular problems of different agro ecological zones. It is hoped that the book represents the first step in disseminating AfNet results, concepts and recommendations to its clients.

A second book on “Managing Nutrient Cycles to Sustain Soil Fertility in Africa” will be published next month and distributed to all Afnet members.

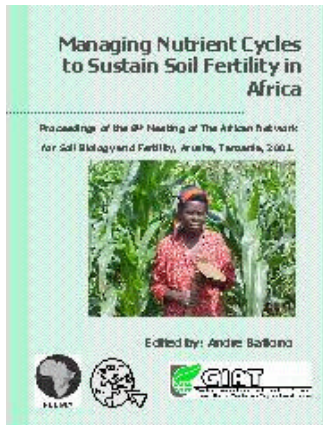

The proceedings of the AfNet 8 Arusha meeting which was held in May, 2001 are ready and the galley prove copy is out under the title “Managing Nutrient Cycles to Sustain Soil Fertility in Africa”. (Edited by: A. Bationo)

Several papers have been prepared within the framework of this project and they are attached in annex of this report

Networks of Agricultural Information Dissemination in Emuhaya, Western Kenya

Michael Misiko (TSBF-CIAT), Joshua J. Ramisch (TSBF-CIAT) and Leunita Muruli (University of Nairobi).

Submitted to the IIED

Researchers interested in technology dissemination are increasingly targeting farmer-to-farmer extension techniques. However, farmer networks form for a variety of reasons, and different actors perceive their benefits in many different ways. This paper describes the role of social networks in soil fertility management among small-scale cultivators in Western Kenya. Data for the study were collected from farmers using a semi-structured questionnaire, group discussion, in-depth interviews and direct observation. By and large, agricultural activities still dominate the agenda of rural community institutions. However, the exchange of soil fertility is increasingly accorded low priority in social interactions between farmers, because of poor returns from farming under current conditions of land and labour scarcity. Many farmers put greater priority on using networks for business, formal employment, politics (favours, handouts, appointments, etc.) or infrastructure development. Networks of farmers are formed on the basis of friendship, proximity and buffering against uncertainty. These factors are effective reminders of the value of networking within community institutions. These findings have important implications for agricultural technology dissemination and adoption in developing countries.

While every farmer involved in this study was involved in social networks, the use of these networks for farmer-to-farmer extension is as complicated as the networks themselves. To disseminate agricultural knowledge through channels that have evolved for a multitude of social, cultural, and economic reasons, one needs to understand the local institutions, agricultural practices and preferences of local farmers. Therefore, researchers and extension workers need to understand the social interactions within local institutions and how these institutions can better serve memberships from varying socio-economic backgrounds.

There is also a need to involve farmers in community institutions directly in the dissemination of knowledge. Transferring more of the research and dissemination process off-station and into farmers' hands should not just be viewed as a cost-saving measure, but one of legitimate empowerment. Currently, local innovation is being hampered by the farmers' (often-justified) anticipation that the researched soil fertility technologies generate poor returns. If farmers can monitor and evaluate their activities, the costs and benefits of innovations can be better understood and a subsequent generation of more relevant and effective technologies will result. We can also expect to see greater farmer commitment and thus the greater involvement of their social networks. Such an evolution may involve unlearning old practices on the part of both development agents and farmers. It was observed in this study, as in previous ones, that greater facilitation and involvement of farmers as full partners in research and dissemination would enhance innovation of indigenous technologies. Researchers and extension agents also need to acknowledge that the *sharing* of information through networks is by definition a 'two-way' learning process, which ultimately generates important understanding of local realities. Questions that need to be clearly understood include: how and when do farmers innovate, who amongst them is foremost in innovating and how do they trust technologies from within and outside and share them amongst themselves?

Activity 5.4 Strengthen linkages with regional organizations and advanced research organizations.

Activity 5.5 Promote awareness of ISFM issues with policy and decision makers.

3. ANNEXES

1. Project Description and Logframe

1.1. Project Description

Goal:

Empowering farmers to conduct sustainable agroecosystem management by increasing capacity for integrated soil fertility management through the generation and sharing of knowledge and tools across multiple scales.

Objective:

To develop and disseminate to clients strategic principles, concepts, methods and management options for protecting and improving the health and fertility of soils through manipulation of biological processes and the efficient use of soil, water and nutrient resources in tropical agroecosystems.

Outputs:

- 1) Improved System resilience and profitability through diversification and intensification of agricultural production
- 2) Improved agroecosystem health through management of BGBD (belowground biodiversity)
- 3) Enhanced provision of soil-based ecosystem services (water quality and quantity, soil C, erosion control) within food secure land use systems.
- 4) Strategies for scaling up and out of ISFM practices developed, implemented and evaluated
- 5) Research and training capacity of stakeholders enhanced.

Gains:

NARES, NGOs, IARCs, ARIs and private sector working together, in partnership with farmers on ISFM, in key research sites in the savannas, forest margins and hillsides of Africa and Latin America. Soil-quality indicators to assist in assessing soil health are published and used by farmers and extension workers. Guidelines are widely disseminated for selecting and managing productive and resource-use-efficient crop, forage and fruit components in land use systems (notably Quesungal / agroforestry, cereal- legumes/livestock and banana and cassava systems). Decision-support systems for identifying profitable options to manage organic and mineral inputs, crop residues, and green manure for sustained agricultural production and for controlling erosion are disseminated and used by farmers, NGO's and NARES. Capacity of NARS for integrated soil fertility and below ground biodiversity management is strengthened through the AfNET network in Africa and MIS consortium in Central America. Rural poor farmers benefit from adoption of improved food systems that result in increased agricultural productivity, higher income, and environmental protection.

Milestones:

- 2004 Innovations for building-up an arable layer and recuperating degraded lands in savannas available. Indicators of soil quality used for farmer's decision making in hillsides, forest margin and savanna agroecosystems. Decision making tool available for combined management of organic and inorganic resources. Decision support tools available to identify more productive, profitable and resilient smallholder farm production strategies. Documentation and analysis of farmers'

- perceptions, preferences, economics and information flow pathways and use of local knowledge within research to extension linkages. Analysis of the role of social differentiation in the creation and maintenance of soil fertility
- 2006 The relationships between agricultural intensification and the diversity, abundance and function of soil biota understood and processes involved in indirect management of BGBD through cropping system design and in direct management through inoculation strategies quantified. Technological interventions for diversification and intensification of the target farming systems are scaled up using ISFM. List of soil quality indicators available to NARS to monitor soil degradation. Decision support tools used in identification of improved smallholder productivity options and identified improved scenarios tested on-farm. Policy issues affecting investment in natural resource management and integrated soil fertility management identified and addressed.
- 2008 Decision-making tools available for managing soil fertility and productivity on smallholder farms. Farmers adopting improved system components, including crops and soil management technologies. Integrated management of soil harmful and beneficial organisms with a focus on the interaction between pest and nutrient management (IPFSM) evaluated in the targeted farming systems. Develop strategies for demonstrating improved BGBD management and for establishing farmer experimentation. Economic evaluation/valorization of ecosystem services for trade-off analysis and policy recommendations quantified for the different farming systems and land use.

Users:

Principally small-scale crop-livestock farmers and extension workers, NGO's and NARES in tropical agroecosystems of sub-Saharan Africa, Latin America and south-east Asia

Collaborators:

NARS: KARI (Kenya), NARO (Uganda), ITRA (Togo), INRAB (Benin), SRI (Ghana), IER (Mali), IAR (Nigeria), INRAN (Niger), INERA (Burkina Faso); CORPOICA (Colombia), EMBRAPA (Brazil), INTA (Nicaragua), DICTA (Honduras); AROs: CIP, IFDC, ICRAF, IITA, ICRISAT, IRD (France), ETH (Switzerland), JIRCAS (Japan); Universities: Nacional (Colombia), UNA (Nicaragua), UNA and EAP Zamorano (Honduras), Uberlandia (Brasil), Nairobi (Kenya), Kenyatta (Kenya), Makerere (Uganda), Zimbabwe (Zimbabwe), Sokoine (Tanzania), Leuven (Belgium), Paris (France), Bayreuth and Hohenheim (Germany), SLU (Sweden), NAU (Norway), Cornell (USA), Ohio State (USA). Universidade Federal de Lavras (Brazil) Jawaharlal Nehru University (India), Universitas Lampung (Indonesia) Université de Cocody (Cote d' Ivoire), Instituto de Ecologia (Mexico) and Wageningen University and Research Centre

CGIAR system linkages:

Enhancement & Breeding (10%); Crop Production Systems (30%); Protecting the Environment (30%); Saving Biodiversity (10%); Strengthening NARS (20%). Convener of Systemwide Program on Soil, Water & Nutrient Management (SWNM), and contributes to the Ecoregional Program for Tropical Latin America, the African Highlands Initiative ; the Alternatives to Slash and Burn Programme, SSA and Water and Food challenge programmes.

CIAT project linkages:

Integrated soil fertility and soil pest and disease management (IP-1, PE-1), acid-soil adapted components received and adaptive attributes identified for compatibility in systems (IP-1 to IP-5), strategies to mitigate soil degradation (PE-3, PE-4), agro enterprise alternatives to improve profitability of soil management options (SN-1), and

strengthening NARS via participation (SN-2). Climate change and SN-3 , Rural Innovation Institute.

1.2. PROJECT LOGFRAME

Narrative Summary	Measurable Indicators	Means of Verification	Important Assumptions
<p>Goal</p> <p>Empowering farmers to conduct sustainable agroecosystem management by increasing capacity for integrated soil fertility management through the generation and sharing of knowledge and tools across multiple scales.</p>	<p>?? Yields in farmers fields increased. ?? Land degradation halted/reduced. ?? Yields per unit area and input increased. ?? Land use changed</p>	<p>?? Farmers surveys. ?? Regional/national production statistics. ?? Land use surveys (satellite imagery, rapid rural appraisal).</p>	<p>?? Land survey data available ?? Farmers adopt new technologies ?? Socioeconomic conditions are favorable for achieving impact ?? Adequate resources available for soils research</p>
<p>Purpose</p> <p>To develop and disseminate to clients strategic principles, concepts, methods and management options for protecting and improving the health and fertility of soils through manipulation of biological processes and the efficient use of soil, water and nutrient resources in tropical agroecosystems.</p>	<p>?? Technologies for soil improvement/ management developed. ?? Limiting soil -plant-water processes identified. ?? Compatible plant components identified for low fertility soils in crop-livestock systems. ?? Guidelines, manuals and training materials for integrated soil fertility management produced.</p>	<p>?? Scientific publications ?? Soil and crop management guidelines published ?? Decision support systems developed ?? Annual reports</p>	<p>?? Economic analysis of options available ?? Effective linkages within CIAT and partners in S.S.Africa, LA and S.E. Asia ?? Socio-economic inputs available from other projects (e.g., PE-3, BP-1) ?? Field sites accessible</p>
<p>Output 1. Improved System resilience and profitability through diversification and intensification of agricultural production</p>	<p>?? Soil, water, nutrient and knowledge constraints to sustainable production defined, and the understanding of the role of soil biota, multipurpose germplasm, and organic and inorganic resources for sustainable management of land resources improved.</p>	<p>?? Annual Report/ publications ?? Reviews published ?? Documents of synthesized results ?? Detailed tables published in Annual Report. ?? Decision guides for ISFM developed.</p>	<p>?? Sufficient operational funds for soil and plant analyses. ?? Literature on constraints available ?? Farmers continue to participate. ?? Projects SN-2, PE -3 and PE-4 actively participate. ?? Collaboration of participatory research project (SN-3), RII and NARS.</p>
<p>Output 2. Improved agroecosystem health through management of BGBD.</p>	<p>?? Relevant knowledge, methods and decision tools for improved soil management to combat soil degradation, increase agricultural productivity and maintain soil health provided to land users in the tropics.</p>	<p>?? Annual reports/ publications. ?? Management guidelines and decision trees published and available to farmers, NARs, NGOs. ?? Training manual for use with tools. ?? Maps published. ?? Simulation models used to assess alternative</p>	<p>?? Sufficient operational funds available for chemical analyses. ?? Continuity of long-term experiments. ?? Modeling expertise available from partners e.g. Michigan State Univ. USA, IFPRI, CSIRO.</p>

Narrative Summary	Measurable Indicators	Means of Verification	Important Assumptions
		?? management of organic resources for ISFM ?? A policy brief for ISFM produced.	?? Soil biology expertise from IRD/Univ. of Paris available.
Output 3. Enhanced provision of soil based ecosystem services (water quality and quantity, soil C, erosion control) within food secure land use systems.	?? The soil's capacity to provide ecosystem services (global warming potential, water quality and supply, erosion control, nutrient cycling) and maintain soil biodiversity in the face of global change in land use and climate enhanced.	?? Annual reports/ publications. ?? Internationally accepted standard methods for characterization and evaluation of below-ground biodiversity (BGBD), including set of indicators for BGBD loss agreed (GEF funded special Project). ?? Methods for assessing impacts of land management on soil microbial and faunal diversity tested ?? Workplan developed to evaluate interactions between soil management practices and soil-borne pests and beneficial organisms.	?? Collaboration from partners. ?? Information from questionnaires synthesized comparisons made with available PE-3 results. ?? Collaboration with PE -3 on soil erosion in CA. ?? Collaboration with SN-2, PE-4, PE-3 and SWNM Program. ?? Collaboration with PE-4 onland quality indicators at reference sites.
Output 4. Strategies for scaling up and out of ISFM practices developed, implemented and evaluated.	??	??	??
Output 5. Research and training capacity of stakeholders enhanced.	?? Research and training capacity of stakeholders in the tropics in the fields of soil biology, fertility and tropical agroecosystem management enhanced through the dissemination of principles, concepts, methods and tools.	?? Scientific information (theses, publications, workshop reports, project documents) disseminated to network members and all stakeholders ?? Network trials planned and implemented with partners ?? Degree-oriented and on-the-job personnel trained (Farmer, NARS, NGO's)	?? Continued interest/participation of NARS and ARO partners, and national and international universities. ?? Continued support for collaborative activities e.g. systemwide SWNM program.

2 List of Staff

A. TSBF Institute Africa Programme

Senior Staff:

Nteranya Sanginga (Director: Soil Microbiologist), *(100% TSBF Institute)*
Bernard Vanlauwe (Nutrient Cycling Management), *(100% TSBF Institute)*
Andre Bationo (AfNet Coordinator), *(100% TSBF Institute)*
Herbert Murwira (Soil Scientist), *(100% TSBF Institute)*
Huising Jeroen (Land use specialist, BGBD coordinator) *(100% TSBF Institute)*

Senior Research Fellows:

Robert Delve (Soil Fertility Management), *(50% TSBF Institute, 50% Rural Innovation Institute)*
Joshua Ramisch (Anthropologist), *(100% TSBF Institute)*
Tilahun Amede (African Highlands Initiative), *(30% TSBF Institute, 70% AHI)*
Okoth(Land use specialist, BGBD Data base manager) *(100% TSBF Institute)*
Anne Muriuki (Soil Scientist) *50% TSBF Institute, 50% ICRAF)*

Consultants:

Prof Mike Swift (BGBD Project)
Dr Stephen Nandwa (SWNM Project)

Research Assistants:

Catherine Gachengo – Kenya
Isaac Ekise – Kenya
John Mukalama – Kenya
Joseph Kimetu - Kenya
Job Kihara - Kenya
Paul Nyende - Uganda
Peace Kankwatsa - Uganda
Pamela Pali- Uganda
Killian Mutiro – Zimbabwe
Pauline Chivenge – Zimbabwe

Technical Staff:

Wilson Ngului, (Laboratory Technician)
Benson Muli (Laboratory Assistant)
Margaret Muthoni (Assistant Lab. Attendant)
Francis Njenga (Manual Worker)
Laban Nyambega (Research Technician)

Administration Staff:

Charles Ngutu (Finance Officer)
Alice Kareri (Administration Officer)
Juliet Ogola (AfNet Secretary)
Caren Akech (BGBD Secretary)
Caleb Mulogoli (Assistant Account / I.T. Assistant)
Henry Agalo (Driver / Field Assistant)
Elly Akuro (Driver / Field Assistant)

B. TSBF Institute Latin America Programme

Senior Staff:

Edmundo Barrios (Soil Ecology), Project Manager (100% TSBF Institute)
Edgar Amézquita (Soil Physics) (100% TSBF Institute)
Miguel Ayarza (Agronomy) MIS Coordinator, Honduras (40% TSBF Institute, 60% CA Reg.Coord.)
Idupulapati M. Rao (Plant Nutrition) (40% TSBF Institute, 30% IP1, 30% IP5)

Senior Research Fellow

Marco Rondón (C sequestration/GH gases) (100% TSBF Institute)

Postdoctoral Fellows

Axel Schmidt (Soil Fertility/Forages), (33% TSBF Institute, 33% IP5, 33% PE3)
Erik Sindhoj (Landscape/Soil Fertility), (100% TSBF Institute)

Consultants:

Eloina Mesa
Myles Fisher
Phanor Hoyos

Research Associates

Juan Guillermo Cobo
Neusa Asakawa
Marco Tulio Trejo

Research Assistants

Diego Luis Molina
Gloria Marcela Rodríguez
Gloria Ocampo
Gonzalo Borrero
Helena Velásquez
Irlanda Isabel Corrales
Jaumer Ricaurte
Jenny Quintero
Juan Andrés Ramírez
Luis Fernando Chávez
Mariela Rivera Peña

Specialists:

Edilfonso Melo
Jesús Hernando Galvis
José Arnulfo Rodríguez

Secretaries

Carmen Cervantes de Tchira
Cielo Nuñez

Technicians

Amparo Sánchez
Arvey Alvarez S.

Carlos Arturo Trujillo
Gonzalo Rojas (Villavicencio)
Hernán Mina
Jarden Molina
Martin Otero
Maryory Rodríguez A.
Pedro Herrera H. (Villavicencio)

Workers

Adolfo Messu
Darío Franco
Héctor Julio Unda (Carimagua)
Jaime Romero
Joaquín Cayapú
Josefa Salamanca
Luis Soto
Nixon Betancourt (Carimagua)
Vivian Ortega

3. List of Students

Appendix B: Research training capacity of stakeholders enhanced

Name	Nationality	Degree	Institution	Research theme
1. D. Fatondji	Nigerian	Ph.D.	University of Bonn, Germany	Interaction between water harvesting and soil fertility
2. Vincent Bado	Burkinabe	Ph.D.	Laval University in Quebec, Canada	Interaction between organic and inorganic nutrient sources in different cropping system in the Sudano sahelian zone of West Africa
3. Shamie Zingore	Zimbabwean	Ph.D.	Wageningen University, Netherlands	Evaluation of the nutrient use efficiencies of resource management options in smallholder crop-livestock farming systems in Zimbabwe
4. Chris Nyakanda	Zimbabwean	Ph.D.	University of Zimbabwe	Effects of Sesbania sesban and cajanus cajan improved fallows on soil moisture and nutrient dynamics and on maize performance in medium rainfall areas of Zimbabwe
5. Nhamo Nhamo	Zimbabwean	Ph.D.	University of Zimbabwe	An avaluation of the efficacy of organic and inorganic fertilizer combinations in supplying N to crops
6. Jean Nzuma	Zimbabwean	Ph.D.	University of Zimbabwe	Manure management options for increasing crop production in smallholder farming systems of Zimbabwe
7. Bonaventure Kayinamura	Rwandan	Ph.D.	University of Zimbabwe	Potential use of three plant species: Glycine Max, mucuna pruriens and crotalaria grahamiana as soil fertility ameliorants in smallholder farming systems in Zimbabwe: synergistic improvements of water and nutrient use efficiencies
8. Fredrick Ayuke	Kenyan	Ph.D.	University of Nairobi, Kenya	Assessing diversity and population dynamics of macrofauna (earthworms and termites) as influenced by land-use change and impact on soil properties
9. Margaret Mwangi	Kenyan	Ph.D.	University of	Soil functional groups: evaluation of ecosystem engineers and

Name	Nationality	Degree	Institution	Research theme
10. Susan Ikerra	Tanzanian	Ph.D.	Nairobi, Kenya Sokoine University, Tanzania	soil fertility management within agro forestry ecosystems Effect of organic materials on MPR dissolution on an Ultisol in Morogoro, Tanzania
11. Kiros Habtegebriel	Ethiopian	Ph.D.	Norway Agricultural University	Development and evaluation of site-specific integrated nutrient management practices for wheat on Vertisols in semi-arid Northern Ethiopia
12. Jane Kapkiyai	Kenyan	Ph.D.	Cornell University, USA	Effects of Legume Green Manures on Crop Productivity and Nutrient Cycling in Maize -based Cropping Systems of Western Kenya
13. John Ojiem	Kenyan	Ph.D.	Wageningen University, Netherlands	Management of legume green manures in Western Kenya
14. Mercy Kamau	Kenyan	Ph.D.	Wageningen University, Netherlands	Socio-economic evaluation of legume-based systems in Western Kenya
15. Twaha Atenyi	Ugandan	Ph. D.	Agricultural University of Norway	Soil phosphorus transformations and organic matter dynamics
16. Nelson Castañeda	Colombian	Ph.D.	University of Gottingen	Genotypic variation in P acquisition & utilization in A. pintoi
17. Birgit Kucera	German	Ph. D.	University of Freiburg	Characterization of bean genotypes for abiotic stress adaptation
18. Alvaro Rincon	Colombian	Ph.D.	National University	Integration of maize with forages to recuperate degraded pastures in the Llanos of Colombia

Name	Nationality	Degree	Institution	Research theme
19. Karen Tscherning	German	Ph.D.	University of Hohenheim	Simultaneous evaluation of tropical forage legumes for feed value and soil enhancement
20. Elena Velásquez	Colombian	Ph.D.	National University/IRD	Biological indicators of soil quality based on macroinvertebrate communities and relationships with soil functional parameters
21. Kibiby Mtenga	Uganda	Ph.D.	Cornell University	Gender and Soil Fertility Management in Malawi: A Participatory Analysis of Farmers' Incentives to Re-invest in Soil Fertility Management Innovations by Women and Men Farmers.
22. Peter Ebanyat	Uganda	Ph.D.	Wageningen University	Dynamics of Soil Organic Matter and Nitrogen in Farmer Field Schools generated Integrated Soil Fertility Management Practices (draft title).
23. Kibiby Mtenga	Uganda	Ph.D.	Cornell University	Gender and Soil Fertility Management in Malawi: A Participatory Analysis of Farmers' Incentives to Re-invest in Soil Fertility Management Innovations by Women and Men Farmers.
24. ShamieZingore	Uganda	Ph.D.	Wageningen University	Farm-scale evaluation of nutrient use efficiencies of resource management options in smallholder farming systems of Zimbabwe.
25. ArmandoTorrente	Colombia	Ph.D	Nacional, Palmira	Soil-water movement in Magnesic soils

Name	Nationality	Degree	Institution	Research theme
26. Navia, Jorge F.	Colombian	Ph.D	Universidad Nacional	Impact of organic additions of different qualities on soil native rhizobia, VAM and nematodes.
27. Pérez E. Humberto	Colombian	Ph.D	Universidad del Valle	Pollutants and soil water fluxes
28. ChristianThierfelder	German	Ph.D.	Univ.Hohenheim, Germany	Development of soil preserving land use systems in the tropics
29. Martha L.Castellanos	Colombian	Ph.D.	U.Nacional, Palmira / U. of the Guajira	Discussion in a new topic of research
30. Martínez Yolanda Rubiano	Colombian	Ph.D.	U.Nacional, Palmira	Soil degradation indicators for the Llanos

Name	Nationality	Degree	Institution	Research theme
1. PaulineChivenge	Zimbabwean	M.Phil	University of Zimbabwe	Tillage effects on soil organic matter fractions in long term maize trilas in Zimbabwe
2. Killian Mutiro	Zimbabwean	M.Phil	University of Zimbabwe	Adoption of improved manure storage systems by smallholder farmers in drought prone and high potential areas of Zimbabwe

Name	Nationality	Degree	Institution	Research theme
3. Ricaurte, José Jaumer	Colombian	MSc	National University	Impact of aluminium tolerant <i>Brachiaria</i> genotypes on soil quality characteristics of an Oxisol of the Altillanura of the Meta Department of Colombia
4. Correa, Diana Lucia	Colombian	MSc	Universidad Nacional	Biological evaluation of the arable layer
5. James Kinyua	Kenyan	M.Sc.	Kenyatta University, Kenya	Nutrient management by use of agroforestry trees for improved soil productivity
6. Joseph Kimetu	Kenyan	M.Sc.	Kenyatta University, Kenya	Nitrogen fertilizer equivalencies based on organic input quality
7. John Baptist Tumuhairwe	Ugandan	M.Sc.	Makerere University, Uganda	Effect of short-duration <i>Crotalaria grahamiana</i> and <i>Mucuna pruriens</i> fallows on soil productivity in southeastern Uganda
8. Matthew Kuule	Ugandan	M.Sc.	Makerere University, Uganda	The effect of green manures, <i>Mucuna</i> , <i>Lablab</i> , <i>Canavalia</i> and <i>Crotalaria</i> on soil fertility and productivity in Tororo District, Uganda
9. Dennis Wafula	Kenyan	M.Sc.	Jomo Kenyatta University, Kenya	The contribution of different feeding guilds of termites to nutrient cycling in soil
10. Pamela Pali	Ugandan	M.Sc.	Makerere University, Uganda	The acceptance and profitability of biomass transfer and legume cover crops in Tororo district, Uganda
11. Ali Lule	Ugandan	M.Sc.	Makerere University,	The role of social capital in adoption of soil fertility technologies

Name	Nationality	Degree	Institution	Research theme
12. Abas Isabirye	Ugandan	M.Sc.	Uganda Makerere University, Uganda	Communication flow between service providers and farmers
13. Paul Bagenze	Ugandan	M.Sc.	Makerere University, Uganda	Linking farmers preferences and GIS for targeting of soil fertility technologies
14. Patricia Namwanda	Ugandan	M.Sc.	Makerere University, Uganda	Techniques and criteria for extrapolation of soil fertility technologies: From farm to the regional level
15. Eria Bulega	Ugandan	M.Sc.	Makerere University, Uganda	Extrapolation domains for countrywide targeting of legume cover crop technologies
16. A.N. Other	Ugandan	M.Sc.	Makerere University, Uganda	Utilization of dual-purpose live barriers for soil water conservation and increased household income
17. John Mutihero	Zimbabwean	M.Sc.	University of Zimbabwe	An assessment of profitability of cattle manure use and the relative impacts on rural farming households in Mangwende communal area, Zimbabwe
18. U. Chipfupa	Zimbabwean	M.Sc.	University of Zimbabwe	The potential of decision guides as an extension tool in improving adoption of integrated soil fertility management options
19. Charles Nhemachena	Zimbabwean	M.Sc.	University of Zimbabwe	Comparative analysis of grain legume production and domestic consumption trends in Zimbabwe' s dual farming sector and the policy challenges for the post land reform era

Name	Nationality	Degree	Institution	Research theme
20. Julius Mumo Maithya	Kenyan	M.Sc.	University of Nairobi	The Competitiveness of Agroforestry-based and other Soil Fertility Enhancement Technologies for Smallholder Food Production in Western Kenya
21. Paul Bagenze	Ugandan	M.Sc.	Makerere University	Identifying target areas for the introduction of legume cover crops for soil productivity improvement in seven districts of eastern Uganda using GIS approach Makerere University, Uganda
22. Somoni Franklin Mairura	Kenyan	M.Sc.	Kenyatta University, Kenya	The Competitiveness of Agroforestry-based and other Soil Fertility Enhancement Technologies for Smallholder Food Production in Western Kenya
23. Isabirye Abas	Ugandan	M.Sc.	Makerere	The diffusion of green manure cover crop technologies in Kisoko and Osukulu sub-counties, Tororo district, Uganda Makerere University, Uganda
24. Pablo Tittonell	Argentinian	M.Sc.	Wageningen University, Netherlands	Farmer-induced soil fertility gradients and their impact on soil processes affecting the efficiency of nutrient capture in smallholder farming systems in East Africa
25. Jenny Ordoñez	Ecuadorian	MSc	Wageningen University	Farm typologies, resource and nutrient flows in farms under Quesungual system, Honduras
26. Lule Ali	Ugandan	MSc	Makerere University	The role of social capital and other social factors in the adoption process of soil fertility management technologies in Tororo district
27. Pamela Pali:	Ugandan	MSc	Makerere University	The acceptance and profitability of biomass transfer and legume cover crops in Tororo district.

Name	Nationality	Degree	Institution	Research theme
28. Mercy Karunditu	Kenyan	M.Sc	Kenyatta University, Kenya	Nitrogen fertilizer use efficiency as affected by soil organic matter status in Eastern, Central, and Western Kenya
29. Boaz Waswa	Kenyan	M.Sc	Kenyatta University, Kenya	Soil Organic Matter Status under Different Agroforestry Management Practices in Three Different Sites in Kenya
30. Adriana Arango	Colombian	M.Sc.	National University	Identification of candidate genes for aluminium resistance in Brachiaria
31. Oscar Molina	Colombian	M.Sc.	National University	Effect of residual P fertilizer and organic manure application on mycorrhizal association of maize-bean rotation in P-fixing Andisol in Cauca, Colombia
32. José Trinidad Reyes	Honduran	M.Sc.	National University	Potential influence of mycorrhizal external mycelia on the recuperation of degraded soils in Cauca, Colombia
33. Ivonne Valenzuela	Colombian	M.Sc.	U.Nacional, Palmira	Relationship between free soil water and its composition in Vertisols
34. Jaime Lozano Fernández	Colombian	M.Sc.	U.Nacional, Palmira	Variability of soil physical properties in CIAT Experimental Station
35. José Augusto Rodríguez Trujillo	Colombian	M.Sc.	U.Nacional, Palmira	Influence of some a amendments in some physical, chemical and biological characteristics of a magnesium soil.
36. Mariela Rivera Peña	Colombian	M.Sc.	U.Nacional, Palmira	Chemistry of tropical soil
37. Rodríguez Atehortua		M.Sc.		Colombian and Brazilian Oxisols

Name	Nationality	Degree	Institution	Research theme
38. Barrios, Dumas León	Colombian	M.Sc.	U.Nacional, Palmira	Specific soil site characterizations in ITA-Buga
Name	Nationality	Degree	Institution	Research theme
39. Eria Bulega	Ugandan	M.Sc.	Makerere University	Farmers' adaptation of legume cover crop technology in eastern Uganda.
40. Patricia Namwanda	Ugandan	M.Sc.	Makerere University	Mapping farm types for the expansion of legumes as cover crops
41. Grace Agwaru	Ugandan	M.Sc.		Assessing Approaches and Developing Methods For Presentation of Research Results To Farmers Within Their Livelihood Situations: A Case Study In Soroti And Arua Districts
42. Dick Lufafa	Ugandan	M.Sc.	Makerere University	On-farm comparison of the economic profitability of selected dual purpose live barriers
43. Nelson Juma Otwoma	Kenyan	MA	University of Nairobi	The role of indigenous knowledge in the management of soil fertility among smallholder farmers of Emuhaya division

Name	Nationality	Degree	Institution	Research theme
1. L. Rusinamhodzi	Zimbabwean	B.Sc.	University of Nairobi	Linking farmer criteria and laboratory indices for on-farm prediction of manure quality in smallholder farming areas of Zimbabwe
2. Talkmore Mombeyarara	Zimbabwean	B.Sc.	University of Nairobi	The potential of <i>Ipomoea stenosiphon</i> (Gubvuwa) plant as a soil fertility ameliorant: A comparison with other agroforestry species
3. German Manrique	Colombian	B.Sc.	National University	Screening of common bean genotypes for aluminium resistance
4. Maria E. Butrago	Colombian	B.Sc.	University of Valle	Screening of <i>Brachiaria</i> hybrids for aluminium resistance
5. Luisa F. Escobar	Colombian	B.Sc.	Javeriana University	Symbiotic potential of native rhizobia under different land use systems in Cauca, Colombia
6. Lorena Parra Lopez	Colombian	B.Sc.	University of Valle	Screening methods for aluminium resistance in common bean
7. Enna Diaz Betancourt	Colombian	B.Sc.	Fund. Universitaria de Popayán	Soil physical characterization in Cauca Paramo soils
8. José Manuel Campo	Colombian	B.Sc.	U.Nacional, Palmira	Evaluation of some crop systems in relation to erosion in Volcanic Ash Soils (Pescador)
9. Liliana Paz Betancourt	Colombian	B.Sc.	Fund. Universitaria de Popayán	Soil physical characterization in Cauca Paramo soils
10. Lina María Gaviria	Colombian	B.Sc.	U.Suramericana, Neiva	Characterization of surface biogenic structures under different cassava treatments in Santander de Quilichao
11. Rafael Andrés Jaramillo Ordóñez	Colombian	B.Sc.	U.Nacional, Palmira	The influence of the intensity of soil management in some physical conditions in CIAT Station
12. Roberto Arturo Viveros	Colombian	B.Sc.	U.Nacional,	The influence of the intensity of soil management in some physical

Name	Nationality	Degree	Institution	Research theme
Alvarez			Palmira	conditions in CIAT Station
13. German Manrique	Colombian	B.Sc.	National University	Screening of common bean genotypes for aluminium resistance
14. Maria E. Butrago	Colombian	B.Sc.	University of Valle	Screening of <i>Brachiaria</i> hybrids for aluminium resistance

4. Collaborators

A. TSBF Institute Africa Programme

AROs:

CDR, Denmark: Esbern Fris-Hassen
Centro Nacional de Pesquisa de Soja (CNPES), Brazil: George Brown
CSIRO-APSRU, Australia: Merv Probert
FAO, Rome
Foundation for Advanced Studies in International Development (FASID, Tokyo).
IDRC, Canada: Guy Bessette
IDRC, Kenya: Luis Navarro
IFDC, Togo: Constant Dangbenon, M.Wopereis, A.Mando
Instituto de Ecologia, A.C., Mexico: Isabelle Barois, Dan Bennack, Carlos Fragoso
International Center for Insect Physiology and Ecology (ICIPE), Nairobi, Kenya
IRD, University of Paris: Patrick Lavelle
World Bank: Beverly Macyntree

Universities:

Alemaya University, Alemaya, Ethiopia
Amadou Bello University, Zaria, Nigeria: E. Iwuafor
Catholic University of Leuven (K.U.Leuven), Leuven, Belgium
Cornell University, Ithaca, USA
Egerton University, Tegemeo Institute, Kenya
Exeter University, UK: Jo Anderson
University of Reading
Jawaharlal Nehru University, India: KG Saxena
Kenyatta University: Daniel Mugendi, Ruth Kangai, Monicah Mucheru and James Kinyua
Makerere University, Uganda: Mary Okwakol, Mary Silver
Mekelle University, Ethiopia;
Sokoine University of Agriculture: Susan Ikerra
Université de Cocody: Yao Tano
Université Federal de Lavras, Brasil: Fatima Moreira
University Lampung, Indonesia: FX Susilo, Muhajir Utomo
University of Abidjan-Cocody, Côte d'Ivoire: Y. Tano,
University of Agricultural Sciences: DJ Bagyaraj
University of Nairobi: Leonita Muruli, Isaac Nyamongo, Lydia Kimenye, Richard Mibey
University of Reading: Geoff Warren
University of Zambia
University of Zimbabwe: Paul Mapfumo and Florence Mtambanengwe
Wageningen Agricultural University, Wageningen, The Netherlands
Cornell University: Chris Barrett
University of London, Queens Mary College, UK: David Bignell

CGIAR Centers

CIMMYT, Kenya: Hugo de Groote
CIP, Kenya: Charles Crissman
ICRAF, Kenya: Frank Place, Steve Franzel, Noordin Qureish, Bashir Jama
ICRISAT, Kenya: Ade Freeman
ICRISAT, Mali: Tabo
ICRISAT, Niger: Aboudoulaye, Abdoulaye and Mahamane
ICRISAT, Zimbabwe: John Dimes

IITA Research Station, Ibadan, Nigeria- Abdou
ILRI, Kenya: Patti Kristjanson, Steve Staal, Philip Thornton, Mario Herrero, Dannie Romney

NARES:

ARS, Chilanga, Zambia: Moses Mwale,
Agricultural Policy Research Unit of Bunda College, Malawi
AHI-Ethiopia: Tilahun Amede
AHI-Tanzania: Jeremiah Mowo, Juma Wickama
Areka Research Centre, Ethiopia
Awassa College of Agriculture, Awassa, Ethiopia
Chidetze, Malawi: Webster Sekala
CRRANiono, Mali: M. Bagoyoko
DR&SS, Zimbabwe: Nhamo Nhamo, Tarasai Mubonderi
Ethiopian Agricultural Research Organization (EARO), Addis, Ethiopia
Holeta Research Center, Holeta, Ethiopia
INERA, Burkina Faso: V. Bado
Institut National de Recherche Agronomique (INRA), Togo- B.K. Tossah
Institut National des Recherches Agricoles du Benin (INRAB), Cotonou, Benin
Institut Togolais de Recherche Agronomique (ITRA), Lome, Togo
Institute for Agricultural Research (IAR), Zaria, Nigeria: E. Iwuafor
KARI-Embu: Alfred Micheni, Francis Kihanda
KARI-Kakamega, Kenya: Rueben Otsyula, David Mbakaya, Martin Odendo
KARI-Muguga, Kenya: Stephen Kimani
KARI-NARL: Nairobi: Stephen Nandwa
KEFRI, Kenya
Ministry of Agricultural and Livestock Development (MoALD), Kenya
Ministry of Agriculture, Kenya, Ethiopia, Malawi and Uganda
Ministry of Health, Israel: Dorit Kaluski
NARO, Uganda: John Byalebeka
NSS, Mlingano, Tanga, Tanzania: Susan Ikerra and Atanasio Marandu,
Salien Agricultural Research Institute, Lushoto, Tanzania
Soil Research Institute, Kwadaso, Kumasi, Ghana: E. Yeboah

Non-Governmental Organizations:

Africa 2000 Network (A2N), Uganda
Africare, Zimbabwe
AREX, Zimbabwe: W.Mpangwa, J.Nzuma
AT (Uganda)
Bunda College of Agriculture, Malawi
CARITAS, Uganda
CNFA
DARTS, Malawi: W.Sakala
DR&SS, Zambia: M.Mwale
Farmer Groups in Vihiga, Siaya, Busia, Teso, and Kakamega districts of western Kenya and Meru South district of central Kenya, Tororo and Mayuge districts of Uganda; farmer groups in Lushoto (Tanzania), Togo and Benin.
Forestry Research Institute (FORI), Uganda
FOSEM, Uganda
KWAP (Kenya Woodfuel and Agroforestry Project)
PLAN International, Uganda
SDARMP, Zimbabwe: D.Saunders
SG2000 Agriculture Programme, Uganda
Smallholder Floodplain Development Project, Malawi: J. Chisenga

System-wide Livestock Program (SLP)

NARS:

CORPOICA – Bogotá, Colombia: Juan Jaramillo
CORPOICA – Bucaramanga, Colombia: Hernando Méndez
CORPOICA– La Libertad (Villavicencio), Colombia: A. Rincón, J.J. Rivera, C.J. Escobar, Jaime H. Bernal, Diego Aristizábal, José E. Baquero, Emilio García, Rubén Valencia, Carmen R. Salamanca
CORPOICA – Macagual, Colombia: Carlos Julio Escobar
CORPOICA – Medellín, Colombia: Alvaro Tamayo
CORPOICA – Obonuco (Pasto), Colombia: Luis F. Campuzano, Bernardo García
CORPOICA – Palmira, Colombia: Jorge Peña, Gloria Ortiz, Carlos Arturo Rincón, Ferney Salazar
CORPOICA – Tibaitatá, Colombia: Inés Toro, Margarita Ramírez
CORPOICA – Turipaná (Montería), Colombia: Nora Jiménez, Sony Reza, Socorro Cajas, Carlos Sánchez, Joaquín García

NGOs:

ASOGRANDE, Caicedonia, Colombia: Roberto Tiznes Mejía
CENICAFE, Chinchina: Siavash Sadeghian, Alveiro Salamanca, Nestor Riaño
CENIPALMA, Bogotá: Fernando Munévar, Pedro León Gómez
CETEC: Kornelia Klaus, Aníbal Patiño
CIPASLA, Pescador: Rodrigo Vivas
CIPAV: Enrique Murgueitio, María Cristina Amézquita, María Elena Gómez
COLCIENCIAS, Bogotá: Oscar Duarte, Jaime Jiménez
COSMOAGRO, Palmira: Antonio López
CRC (Corporación Regional del Cauca), Popayán: Jesús A. Chávez
CVC (Corporación del Valle del Cauca), Cali: Eduardo Varela, Enrique Alejandro Torres, Alvaro Calero
FEDEARROZ, Ibagué: Alvaro Salive, Armando Castilla
IPF (Instituto de Fósforo y Potasio), Ecuador: José Espinosa
MONOMEROS COLOMBO-VENEZOLANOS, Bogotá: Ricardo Guerrero, Alberto Osorno
PALMAS DE CASANARE, Villavicencio: Juliana Betancourt

Specialized Institutions:

Agricultural University of Norway, Norway; Prof. B.R. Singh
Berlin University of Technology, Berlin, Germany: Wilcke Wolfgang
College on Soil Physics, Trieste, Italy: Miroslav Kutilek, Idelfonso Pla
Cornell University: Dr. J. Thies
ETH, Zurich, Switzerland; Prof. E. Frossard, A. Oberson
ESNACIFOR (National School for Forestry Service), Siguatepeque, Honduras: Samuel Rivera
FAO-Lempira Sur, Honduras: Luis A. Welchez, Paul Compton
IGAC (Instituto Geográfico Agustín Codazzi), Bogotá-Colombia: Dimas Malagón, Napoleón Ordoñez
IIAP (Instituto de Investigaciones Ambientales del Pacífico), Quibdó (Chocó), Colombia: Eduardo García Vega, Luis Carlos Pardo Locarno, Jesús Eduardo Arrollo Valencia
IICA, Bogotá-Colombia: Fabio Bermúdez
INTA/CENIA, Managua, Nicaragua: Jellin Pavon
Instituto de Ecología, Jalapa, México, Dr. Isabel Barois
Michigan State University; Prof. James Tiedje
Ministerio de Agricultura de Colombia: Fabio Clavijo, Juan Lucas Restrepo
Ohio State University, USA: Rattan Lal
Silsoe College, U.K.: Eduardo González

Sociedad Colombiana de la Ciencia del Suelo-SCCS, Bogotá-Colombia: Germán Peñalosa F., Francisco Silva Mojica
Swedish Agricultural University; Prof. Olle Andren
Universidad de Lleida, Spain: Idelfonso Pla-Sentis
Universita di Trieste, Italy: Giancarlo Ghirardi
Université de Rouen, Rouen, France: Thibaud Decaëns
University of Göttingen, Germany, Prof. N. Claassen
University of California at Berkeley, Dr. David Zilberman, Dr. Robin Marsh
University of California-Davis, United States: Donald Nielsen
University of Chile; Prof. M. Pinto
University of Freiburg; Prof. E. Wellmann
University of Ghent, Belgium: Donald M. Gabriels
University of Hohenheim; Prof. R. Schultze-Kraft
Wageningen University: Prof. Peter Buurman, Prof. Ken Giller, Dr. Ruerd Ruben

International Agricultural Research Centers:

CATIE, Costa Rica; John Beer, Muhammad Ibrahim
IFDC, USA; D. Friesen

National Universities:

Instituto de Educación Técnica Profesional, Roldanillo: Gustavo A. Ramírez, Alma Lida Obregón
Instituto Técnico Agropecuario-ITA, Buga: Manuel Amaya Navarro
Pontificia Universidad Javeriana, Bogotá, Colombia, Amanda Varela
Universidad de Caldas: Franco Obando, William Chavarriaga
Universidad de Córdoba, Montería: Iván Darío Bustamante
Universidad de la Amazonía: Bertha Ramírez
Universidad de Nariño: Hugo Ruíz, Jesús A. Castillo, Germán Arteaga Meneses, Javier García Alzate
Universidad del Cauca: Clara Hernández, Edier Humberto Pérez
Universidad del Pacífico: Carlos Cas tilla, Alfredo León, Amulfo Gómez -Carabalí
Universidad del Valle: Patricia Chacón, James Montoya, Martha Páez
Universidad Distrital de Bogotá: Miguel Cadena
Universidad Nacional de Colombia, Palmira, Colombia, Alvaro García, Edgar Madero, Marina Sánchez de Prager, Eugenio Escobar, Raúl Madriñán
Universidad Tecnológica de los Llanos: Jorge Muñoz, Gabriel Romero, Obed García, Julio César Moreno
Universidad Tecnológica de Pereira: Alex Feijoo

Regional Universities:

Escuela Nacional de Agricultura (ENA), Honduras: José T. Reyes
Jawaharlal Nehru University, New Delhi, India, Dr. K.G.Saxena
United States Internaitonal University, Kenya, Dr. James Kahindi
Universidad Central de Venezuela (UCV): Luis Bulla, Deyanira Lobo
Universidad de Costa Rica: Alfredo Alvarado, W. Forsythe
Universidad de Lavras, Brazil, Dr. Fátima Moreira
University of Lampung, Indonesia, Dr. Abdul Gafur
Universidad de los Andes, Mérida, Venezuela: Lina Sarmiento, Dimas Acevedo
Universidad Nacional Agraria (UNA), Nicaragua: Matilde Somarriba
Universidad Nacional Autónoma de México, Dr. Esperanza Martinez
Universidade de Sao Paulo, Brazil: Klaus Reichardt
Universidade Estadual de Londrina, Brazil: María de Fátima Guimaraes, Ricardo Ralich
Universidade Federal de Santa Maria, Brazil: Telmo Jorge Amado

5. List of Publications

Refereed journal articles:

- Amede, T. and S.Schubert, S. 2003. Mechanisms of drought resistance in grain legumes. I: Osmotic adjustment. *SINET: Journal of Science*: 26(1) 000-000.
- Amézquita, E., Thomas, R. J., Rao, I. M., Molina D. L. and Hoyos. P. 2003. The influence of pastures on soil physical characteristics of an oxisol in the eastern plains (Llanos Orientales) of Colombia. *Agriculture, Ecosystems and Environment* (In press).
- Barrios E. and Cobo J.G. 2003 Plant growth, biomass production and nutrient accumulation by slash/mulch agroforestry systems in tropical hillsides of Colombia. *Agroforestry Systems* (in press)
- Barrios E. and Trejo M.T. 2003 Implications of local soil knowledge for integrated soil management in Latin America. *Geoderma* 111: 217-231
- Barrios, E., Cobo, J. G., Rao, I. M., Thomas, R. J., Amézquita, E. and J. J. Jiménez. 2003. Fallow management for soil fertility recovery in tropical Andean agroecosystems in Colombia. *Agriculture, Ecosystems and Environment* (In press).
- Begum, H. H., Osaki, M., Nanamori, M., Watanabe, T., Shinano, T., and Rao, I. M. 2003. Role of phosphoenolpyruvate carboxylase in the adaptation of a tropical forage grass, *Brachiaria* hybrid, to low phosphorus acid soils. *Journal of Plant Nutrition* (in press).
- Decaëns, T., Mariani, L., Nixon Betancourt and Jiménez, J. J. 2003. Seed dispersión by surface casting activities of earthworms in Colombian grasslands. *Acta Oecologica* 24: 175-185.
- Diels, J., Vanlauwe, B., Van der Meersch, M. K., Sanginga, N. and R. Merckx, J., B 2003 Long-term soil organic carbon dynamics in a subhumid tropical climate: ¹³C data and modeling with RothC. *Soil Biology and Biochemistry*, In Press.
- Douthwaite, B., Delve, R.J., Ekboir, J. and Twomlow, S. 2003 Contending with Complexity: The Role of Evaluation in successful INRM. *International Journal of Agricultural Sustainability* 1:51-66
- Kimetu, J.M., Mugendi, D.N., Palm, C.A., Mutuo, P.K., Gachengo, C.N., Bationo, A., Nandwa, S., Kungu, J. B. 2003. Nitrogen fertilizer equivalencies of organic materials of differing quality and optimum combination with inorganic nitrogen sources in Central Kenya. *Nutrient Cycling in Agroecosystems Journal* (Accepted: August 2003).
- Nanamori, M., Shinano, T. Yamamura, T., Rao, I. M. and Osaki, M. 2003. Low phosphorus tolerance mechanisms: Phosphorus recycling and photosynthate partitioning in tropical forage grass, *Brachiaria* hybrid cultivar Mulato compared with rice. *Plant Physiology* (in review).
- Nyende, P. and Delve, R.J. 2003. Farmer participatory evaluation of legume cover crop and biomass transfer technologies for soil fertility improvement using farmer criteria, preference ranking and logit regression analysis. *Experimental Agriculture* 40:1-12
- Nwoke, O. C., Vanlauwe, B., Diels, J., Sanginga, N. and Osonubi, O. 2003. Improvement of phosphorus availability in West African moist savanna soils: the impact of residue characteristics. *Biology and Fertility of Soils*, In Press.

- Oberthur, T., Barrios E., Cook S., Usma H., Escobar G. 2003. Increasing the relevance of scientific information in hillside environments through understanding of local soil management in a small watershed of the Colombian Andes. *Soil Use and Management* (in press)
- Oorts, K., Vanlauwe, B., Recous, S. and Merckx, R. 2003. Evaluation of ultrasonic dispersion for the isolation of soil organic matter fractions in highly weathered soils. *European Journal of Soil Science*, In Press.
- Oorts, K., Vanlauwe, B., Recous, S. and Merckx, R. 2003. Redistribution of particulate organic matter in different states of decomposition during ultrasonic dispersion, *European Journal of Soil Science*, In Press.
- Oorts, K., Vanlauwe, B., Pleysier, J., S. and Merckx, R. 2003. A new method for the simultaneous measurement of pH-dependent cation exchange capacity and pH buffering capacity. *Soil Science Society of America Journal*, In Press.
- Phiri, S., Amezquita, E., Rao, I. M., and Singh, B. R. 2003. Constructing an arable layer through chisel tillage and crop-pasture rotations in tropical savanna soils of the Llanos of Colombia. *Journal of Sustainable Agriculture* (in press).
- Phiri, S., Rao, I.M., Barrios, E. and Singh, B. R. 2003. Plant growth, mycorrhizal association, nutrient uptake and phosphorus dynamics in a volcanic-ash soil in Colombia as affected by the establishment of *Tithonia diversifolia*. *Journal of Sustainable Agriculture* 21: 43-61.
- Sangare, M., Bationo, A., Hiernaux P., Fernandez-Rivera S. and Pandey V. S. 2002. Influence of dry season supplementation for cattle on soil fertility and millet (*Pennisetum glaucum* L.) yield in a mixed crop/livestock production system of the Sahel. *Nutrient Cycling in Agroecosystems*, 62, 209-217.
- Sangare, M., Bationo, A., Hiernaux, P., Fernandez-Rivera, S. and Pandey, V. S. 2002. Effect of type and level of roughage offered to sheep and urine addition on compost quality and millet growth and production in the Sahel. *Nutrient Cycling in Agroecosystems*, 62, 203-208.
- Sangare M., Fernandez-Rivera, Hiernaux P., Bationo A. and Pandey, V.S. 2002. Influence of dry season supplementation for cattle on soil fertility and millet (*Pennisetum glaucum* L.) yield in a mixed crop/livestock production system of the Sahel. *Nutrient Cycling in Agroecosystems*, 62, 209-217.
- Sangare, M., Bationo, A., Hiémaux, P., Fernandez-Rivera, S. and Pandey, V.S. 2002. Effect of type and level of roughage offered to sheep and urine addition on compost quality and millet growth and production in the Sahel. *Nutrient Cycling in Agroecosystems*, 62, 203-208.
- Sanginga, N, Dashiell, K., Diels, J., Vanlauwe, B., Lyasse, o., Carsky, R. J., Tarawali, S., Asafo-Adjei, B., Menkir, A., Schulz, S., Singh, B. B., Chikoye, D., Keatinge, D. and Rodomiro, O. 2003. Sustainable resource management coupled to resilient germplasm to provide new intensive cereal-grain legume-livestock systems in the dry savanna. *Agriculture, Ecosystems and Environment*, In Press.
- Sharrock, R. A., Sinclair, F. L., Gilddon, C., Rao, I. M., Barrios, E., Mustonen, P. J., Smithson, P., Jones, D. L. and D. L. Godbold. 2003. A global assessment of mycorrhizal colonization of *Tithonia diversifolia*. *Mycorrhiza* (in press).
- Shepherd, K. D., Palm, C. A., Gachengo, C. N., and Vanlauwe, B. 2003. Rapid characterization of organic resource quality for soil and livestock management

- in tropical agroecosystems using near infrared spectroscopy. *Agronomy Journal*, In Press.
- Watanabe, T., Osaki, M., Yano, H. and Rao, I. M. 2003. Internal mechanisms of plant adaptation to aluminum toxicity and phosphorus starvation in three tropical forages. *New Phytologist* (in review).
- Wenzl, P., Mancilla, L. I., Mayer, J. E., Albert, R. and Rao, I. M. 2003. Simulating infertile acid soils with nutrient solutions and the effects on *Brachiaria* species. *Soil Sci. Soc. Am. J.* 67: 1457-1469.
- Zhiping, Q., Rao, I. M., Ricaurte, J., Amézquita, E., Sanz, J., and Kerridge, P. 2003. Root distribution effects on nutrient uptake and soil erosion in crop-forage systems on Andean hillsides. *J. Sust. Agric.* (in press).
- Yamoah, C.F., Bationo, A., Shapiro, B. and Koala, S. 2003. Soil management practices to improve nutrient-use efficiencies and reduce risk in millet-based cropping systems in the Sahel. *TROPICULTURA* Vol. 21, 2: 66- 72
- Yamoah, C.F., Bationo, A., Wyatt, T.J., Shapiro, B. and Koala, S. 2003. Simulated weather variables effects on millet fertilized with phosphate rock in the Sahel. *Nutrient Cycling in Agroecosystems* 67: 167-176

Review articles:

- Amézquita, E., Rao, I. M., Hoyos, P., Molina, D. L., Chávez, L. F. and Bernal, J. H. 2003. Development of an arable layer: A key concept for better management of infertile tropical savanna soils (in review).
- Kelemu, S., Mahuku, G., Fregene, M., Pachico, D., Johnson, N., Calvert, L., Rao, R. Buruchara, R., Amede, T., Kimani, P., Kirkby, R., Kaaria, S. and Ampofo, K. 2003. Harmonizing the agricultural biotechnology debate for the benefit of African farmers. *African Biotechnology Journal* (in review).

Refereed book chapters:

- Bationo, A., Mkwunye, U., Vlek P.L.G., Koala, S, and Shapiro, B. I. 2003. Soil fertility management for sustainable land use in the West African Sudano-Sahelian zone. Pp 253-292. In: Gichuru M.P., Bationo A., Bekunda M.A., Goma P.C., Mafongoya P.L., Mugendi D.N., Murwira H.M., Nandwa S.M., Nyathi P. and M.J. Swift. *Soil Fertility Management in Africa: A regional Perspective*. 306 pp
- Gichuru, M. P., Bationo, A., Bekunda, M. A., Goma, P. C., Mafongoya, P. L., Mugendi, D. N., Murwira, H. M., Nandwa, S. M., Nyathi, P. and Swift, M.J. (Eds). 2003. *Soil fertility management in Africa: A regional perspective*. TSBF-CIAT. 2003 306 pp.
- Delve, R. J. Combating nutrient depletion in East Africa – the work of the SWNM program. (AfNet 8 Proceedings: In Press)
- Delve, R.J., Ramisch, J., Kaizzi, K. C. and Ssali, H. Land Management Options in Western Kenya and Eastern Uganda. In: Pender, Ehui and Place (Eds) *Policies for Sustainable Land Management in the East African Highlands*, Conference Proceedings, 24-26 May 2002, ECA, Addis Ababa. (Published by IFPRI, in press)

- Kimani, S.K., Nandwa, S. M., Mugendi, D. N., Obanyi, S. N., Ojiem, J., Murwira, H. K. and Bationo, A. 2003. Principles of integrated soil fertility management. Pp 51-72 In: Gichuru M.P., Bationo, A., Bekunda, M. A., Goma, P. C., Mafongoya, P. L., Mugendi, D. N., Murwira H. M., Nandwa, S. M., Nyathi, P. and M. J. Swift. Soil Fertility Management in Africa: A regional Perspective. 306 pp
- Miles, J. W., do Valle, C. B., Rao, I. M. and Euclides, V. P. B. 2003. Brachiaria grasses. In: L. E. Sollenberger, L. Moser and B. Burson (eds). Warm-season grasses. ASA-CSSA-SSSA, Madison, WI, USA (in press).
- Nyathi, P., Kimani, S. K., Jama, B., Mapfumo, P., Murwira, H. K., Okalebo, J. R., Bationo, A. 2003. Soil fertility management in semi arid areas of East and Southern Africa. Pp 219-252. In: Gichuru M.P., Bationo A., Bekunda M.A., Goma P.C., Mafongoya P.L., Mugendi D.N., Murwira H.M., Nandwa S.M., Nyathi P. and M.J. Swift. Soil Fertility Management in Africa: A regional Perspective. 306 pp
- Rao, I. M. and Cramer, G. 2003. Plant nutrition and crop improvement in adverse soil conditions. In: M. Chrispeels and D. Sadava (eds). Plants, Genes, and Crop Biotechnology. Published in partnership with the American Society of Plant Biologists and ASPB Education Foundation. Jones and Bartlett Publishers, Sudbury, Massachusetts, USA, pp 270-303.
- Rychter, A. M. and Rao, I. M. 2003. Role of phosphorus in photosynthetic carbon metabolism. In: M. Pessaraki (ed). Handbook of Photosynthesis. 2nd Edition. Marcel Dekker, Inc., New York (in press).
- Schroth, G., Lehmann, J. and Barrios, E. 2003. Measuring / predicting the availability of N for trees and crops. In (G.Schroth and F.L.Sinclair, eds) Trees, Crops and Soil Fertility: Concepts and Research Methods. Chapter 2.2. Maintenance and replenishment of soil fertility, CABI.

Conference proceedings:

- Albrecht A, Cadisch, G., E Blanchart, Sitompul, S. M. and Vanlauwe, B. 2003 Belowground inputs: relationships with soil quality, soil C storage and soil structure. In: Belowground Interactions in Tropical Agroecosystems (Eds: M van Noordwijk, CK Ong, G Cadisch). CABI, Wallingford, UK, In Press.
- Akinnifes, F. K., Rowe, E.C., Livesley, S. J., Kwesiga, F.R., Vanlauwe, B. and Alegre, J. C. 2003 Tree root architecture. In: Belowground Interactions in Tropical Agroecosystems (Eds: M van Noordwijk, CK Ong, G Cadisch). CABI, Wallingford, UK, In Press.
- Amede, T., Amézquita, E., Ashby, J., Ayarza, M., Barrios, E., Bationo, A., Beebe, S., Bellotti, A., Blair, M., Delve, R., Fujisaka, S., Howeler, R., Johnson, N., Kaaria, S., Kelemu, S., Kerridge, P., Kirkby, R., Lascano, C., Lefroy, R., Mahuku, G., Murwira, H., Obertur, T., Pachico, D., Peters, M., Ramisch, J., Rao, I. M., Rondon, M., Sanginga, P., Swift, M. and Vanlauwe, B. 2002. Biological nitrogen fixation: A key input to integrated soil fertility management in the tropics. Position paper by CIAT-TSBF Working Group on BNF-CP for International Workshop on Biological Nitrogen Fixation for Increased Crop Productivity, Enhanced Human Health and Sustained Soil Fertility". ENSA-INRA, Montpellier, France (10-14 June, 2002).

- Amede, T. 2003. (Editor) Natural Resource Degradation and Environmental Concerns: Impact on Food Security. Proceedings of the Ethiopian Soil Science Society, Bahir Dar, July 24-26, 2002. 276pp.
- Amede, T. 2003. Opportunities and challenges in reversing land degradation: The regional experience. In: Amede T. (2003): Natural Resource Degradation and Environmental Concerns: Impact on Food Security. Proceedings of the Ethiopian Soil Science Society, Bahir Dar, July 24-26, 2002. pp173-183.
- Amede, T. 2003. Improving drought resistance of grain legumes in Ethiopia: A Physiological approach. Invited paper presented at the "Second National Workshop on Food and Forage Legumes". Addis Ababa, Ethiopia. 22-27 September, 2003 (in press).
- Amézquita, E., Chávez, L. F., Molina, D. L., Hoyos, P. and Galvis, J. H. 2003. Susceptibility to compaction of improved soils (Oxisols) in the Eastern Plains of Colombia. International Soil Tillage Research Organisation Conference, Proceedings of ISTRO-16 "Soil Management for Sustainability". Brisbane, Australia, 13-18 July 2003. pp.29-35.
- Beebe, S., Rao, I., Terán, H. and Cajiao, C. 2003. Breeding concepts and approaches in food legumes: The example of common bean. Invited paper presented at the "Second National Workshop on Food and Forage Legumes". Addis Ababa, Ethiopia. 22-27 September, 2003 (in press).
- Carsky, R. J., Vanlauwe, B. and Lyasse, O. 2002 Cowpea rotation as a resource management technology for cereal-based systems in the savannas of West Africa. Pages 252-266 in Challenges and Opportunities for Enhancing Sustainable Cowpea Production edited by C.A. Fatokun, S.A. Tarawali, B.B. Singh, P.M. Kormawa, and M. Tamò. Proceedings of the World Cowpea Conference III held at the International Institute of Tropical Agriculture (IITA), Ibadan, Nigeria, 4-8 September, 2000. IITA, Ibadan, Nigeria.
- Schroth, G. and Vanlauwe, B. 2003 Soil organic matter. In: Trees, Crops and Soil Fertility (Eds G Schroth and F L Sinclair). CAB International, Wallingford, UK, pp 77-91
- Vanlauwe, B. 2003. Integrated Soil Fertility Management research at TSBF: the framework, the principles, and their application. Proceedings from the 8th Afnet meeting, Arusha, Tanzania.
- Vanlauwe, B., Bationo, A., Carsky, R. J., Diels, J., Sanginga, N. and Schulz, S. 2003. Enhancing contribution of legumes and biological nitrogen fixation in cropping systems: experiences from West Africa. Proceedings from the SoilFertNet meeting, Vumba, Zimbabwe.

Non-refereed conference presentations:

- Beebe, S., Rao, I., Terán, H., Cajiao, C., Ricaurte, J., and Beltran, J. 2003. Progreso en Aumentar Tolerancia a Estrés Abiótico en Frijol Común. Paper presented in the XLIX Meeting of the PCCMCA, Programa Cooperativo Centroamericano de Mejoramiento de Cultivos y Animales. La Ceiba, Honduras. April 27-May 3, 2003.
- Thierfelder, C. and Amézquita, E. 2003. Soil crusting and sealing in the Andean Hillside of Colombia and its impact on water infiltration. Poster for presentation at Deutscher Tropentag 2003, International Research on Food Security,

Natural Resource Management and Rural Development. Georg-August-University Göttingen, October 8-10, 2003.

Tohme, J., Rao, I., Wenzl, P. Beebe, S. and Ishitani, M. 2003. Functional genomics applied to abiotic stress using AI tolerance a simple case and drought as a complex case. Invited paper presented at the Annual Meetings of ASA-CSSA-SSSA, Denver, CO, USA.