

37655  
Inglés

# Legume-Rhizobium Symbiosis

Methods Manual for  
Evaluation, Selection, and Agronomic Management

Compiled by

Section of Soil Microbiology,  
Tropical Pastures Program  
Section of Soil Microbiology,  
Bean Program



A special CIAT-UNDP project for the evaluation  
selection and management of the legume-  
rhizobium symbiosis for increasing nitrogen  
fixation



Centro Internacional de Agricultura Tropical

PED EXTERIOR



Centro Internacional de Agricultura Tropical  
Apartado 6713  
Cali, Colombia

Press run 250 copies Spanish, 150 copies English  
Printed in Colombia  
May 1988

CIAT (Centro Internacional de Agricultura Tropical) 1988

Legume-rhizobium symbiosis Methods manual for evaluation  
selection and agronomic management Soil Microbiology Section of  
the Tropical Pastures Program and Soil Microbiology Section of the  
Bean Program (comps ) [CIAT-UNDP project for the evaluation,  
selection and management of the legume-rhizobium symbiosis for  
increasing nitrogen fixation] Cali, Colombia (Several  
paginations, 172 p )

1 Legumes -- Inoculation 2 Rhizobia 3 Nitrogen -- Fixation  
4 Nitrogen-fixing microorganisms 5 Forage legumes 6 Beans I.  
Centro Internacional de Agricultura Tropical



# Contents

Chapter		Page
	Acknowledgements	v
	Introduction	1
1	Agronomic evaluation of the legume-rhizobium symbiosis	1-1
2	Nodule collection for rhizobium isolation	2-1
3	Isolation of rhizobia from nodules	3-1
4	Storage and reconstitution of rhizobium strains	4-1
5	Characterization of rhizobia	5-1
6	Purity tests for rhizobium cultures	6-1
7	Immunodiffusion test for distinguishing between strains	7-1
8	Additional characteristics of rhizobium strains	8-1
9	Plant infection methods in test tubes, growth pouches and Leonard jars	9-1
10	Rhizobium counts using the most probable number method (MPN)	10-1
11	Viable cell counts of rhizobia using Petri plates	11-1

Chapter		Page
12	Preparation of small quantities of inoculants from pure rhizobium cultures on YMA	12-1
13	Evaluation of the legume-rhizobium symbiosis in undisturbed soil cores (Stages 1 and 2)	13-1
14	Evaluation of the legume-rhizobium symbiosis in pots of soil (Stages 1 and 2)	14-1
15	Evaluation of the forage legume-rhizobium symbiosis in the field (Stages 1 and 2)	15-1
16	Evaluation of the bean-rhizobium symbiosis in the field (Stages 1 and 2)	
17	Methods for evaluating nodulation	17-1
18	Nitrogen determinations	18-1
19	Instructions for experiments with inoculated treatments (Stage 2)	19-1
20	Evaluation of the effects of agronomic management on the symbiosis (Stage 3)	20-1
 APPENDICES		
A	Construction of a sterile hood (NifTAL design)	A-1
B	Acetylene reduction method	A-5
C	Recommended strains	A-10
References		Rf -1

# Acknowledgements

The United Nations Development Program (UNDP), through the Division for Global and Interregional projects, has supported the publication of this manual (Project GLO/004/84)

This manual was compiled by Rosemary Sylvester-Bradley, soil microbiologist of the Tropical Pastures Program, and Judy Kipe-Noit, soil microbiologist of the Bean Program, with help from the following people David J Harris, Fabiola Campuzano de Ramírez, Dacier Mosquera P , Gloria Isabel Ocampo, Pedro A Zapata, Lucía Mejía de Mayor, and Javier Mesa Many other people who used the first edition have contributed suggestions to make this new version more complete and comprehensible





# Introduction

The purpose of this manual is to describe methods available for studies in rhizobiology applicable to tropical agriculture, particularly those for tropical forage legumes and beans. More emphasis is given to applied studies, and no attempt has been made to cover all methods available for studying rhizobia. There are several books on methods for studying  $N_2$  fixation for those who require more information (Bergersen, 1980, Vincent, 1970, IAEA, 1983, FAO, 1983, Somasegaran and Hoben, 1985). We believe that this manual complements the other publications available, because it emphasizes the agronomic aspects of evaluating the symbiosis.

This manual complements the audiotutorial unit produced by the Centro Internacional de Agricultura Tropical (CIAT) entitled Legume-Rhizobium Symbiosis: Evaluation, Selection and Management, which describes some aspects of the most important basic characteristics of the symbiosis and introduces the concepts required for the use of the methods presented here in detail. The objectives and selection stages used in a legume selection program should be defined in close collaboration between the microbiologist, and those responsible for the agronomic evaluation. The ultimate objective of this work is to select legume-rhizobium combinations which show a high  $N_2$ -fixing capacity under local conditions.

The first chapter reviews the concepts presented in the audiotutorial unit. The relationship between the different chapters in the manual and the evaluation stages is also described. Examples are included of selection strategies for forage legumes and beans, two groups of legumes currently being evaluated by CIAT's international programs.

Chapters 2 through 20 contain descriptions of the methods per se and three appendices. The first appendix describes a cheap and simple transfer chamber for laboratory work designed by the NIFTAL project, the second describes the acetylene reduction method which can be used in

some cases for making relative estimations of nitrogenase activity, and the third lists strains recommended for inoculation of beans and tropical forage legumes in different ecosystems. These lists of strains will be revised periodically, interested persons should contact CIAT to obtain updated versions.

Further appendices and information will be added to the manual as needed. We ask users of this publication to send us information or suggestions that may be helpful in updating or revising the methods.

# 1

## AGRONOMIC EVALUATION OF THE LEGUME-RHIZOBIUM SYMBIOSIS

An agronomic evaluation of the symbiosis should complement the evaluation of germplasm for other desirable attributes (e.g., yield, nutritional quality, seed production, disease resistance), in order to select genotypes with the best combination of characters.

This chapter describes practical examples of strategies for this type of evaluation, within the overall framework of a legume selection program.

### 1.1 Objectives, treatments, and parameters for agronomic evaluation of the symbiosis

The objective of the agronomic evaluation of the symbiosis is to select germplasm with maximum potential to fix nitrogen under local conditions. It will not always be necessary to inoculate the selected legumes since, in some cases, an effective symbiosis is formed with native strains. In other cases, it is necessary to select both legumes and rhizobium strains in order to achieve an effective combination of the two symbionts.

Appropriate treatments are used in order to characterize the legumes according to the effectivity of the symbiosis formed with inoculated or native strains. Three types of treatments are considered (Table 1.1). Different combinations of these treatments are chosen to evaluate the effectivity of the symbiosis depending on the selection stage the legume is in.

The evaluation parameters are N yield and nodulation, in the high N treatment only N yield is evaluated since nodulation is inhibited by the presence of mineral N in the soil.

The evaluation of these treatments, in different soil-germplasm combinations, permits the agronomic characterization of the following aspects of the symbiosis: 1) relative effectiveness of the native strains; 2) yield potential of legumes when grown without

Table 1 1 Treatments and parameters used for agronomic evaluation of the legume-rhizobium symbiosis

No	Treatment		Symbol or code	Parameter evaluated
	Available N level	Inoculation application		
1	Low	No	-N or -I	N yield, nodulation
2	Low	Yes	+I or R <sub>1</sub> , R <sub>2</sub> , R <sub>3</sub> , etc	N yield, nodulation
3	High	No	+N	N yield

nitrogen limitation, 3) effect of inoculants on yield, 4) need for genetic improvement of fixation potential through a breeding program, and 5) effect of other agronomic management practices on the symbiosis

1 2 Stages of evaluation of the symbiosis and their relationship to this manual

In order to clearly understand the relationship between the methods described in this manual and the research stages recommended for the evaluation of the symbiosis, consider Figure 1 1 The research follows through the different stages according to the needs and conditions of each particular selection program

Chapters 2 through 12, represented as Stage 1<sub>R</sub> in the diagram, include the procedures necessary for rhizobium management in the laboratory such as isolation characterization storage inoculant production, and inoculant quality control

Chapters 13 through 18 (Stage 1<sub>L</sub>) include the methods for the agronomic evaluation of the symbiosis without the use of inoculants (experiments to determine the need to inoculate), these are methods for establishing experiments in the greenhouse and field with low and high availability of mineral N, nodulation evaluations, and N yield measurements Chapter 19 (Stage 2) contains the methods and

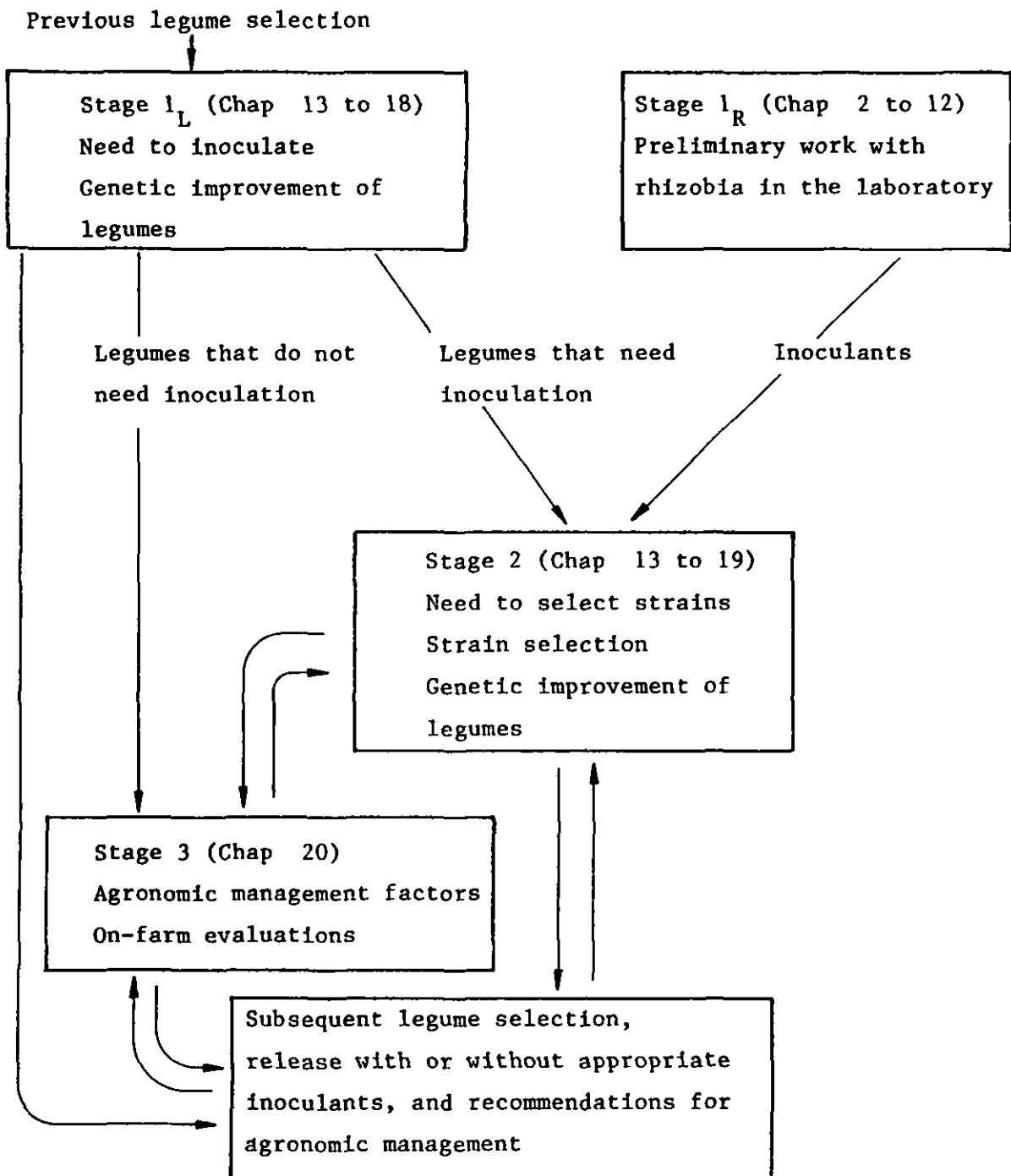

Figure 1 1 Chart of germplasm flow through research stages for increasing nitrogen fixation through management of the legume-rhizobium symbiosis

precautions needed to include and evaluate inoculants in greenhouse and field experiments (experiments to evaluate the need to select strains and experiments to select strains) The agronomic methods and evaluation parameters used in Stage 2 are the same as those used in Stage 1<sub>L</sub> Chapter 20 (Stage 3) describes some additional treatments that can be studied once the most promising legume-rhizobium combinations have been selected in order to evaluate interactions between agronomic management factors and the legume-rhizobium combinations selected in Stages 1 and 2 These Stage 3 experiments are carried out in parallel to the subsequent evaluations shown in Figure 1 1, so that possible problems of technology adaptation to farmers' conditions can be studied

We consider it important to specify the terminology used in Chapters 13 to 19 for describing the recommended treatments For each soil two treatments per legume are used in Stage 1<sub>J</sub> experiments The objective is to evaluate the effectiveness of the native rhizobium strains in a treatment having low mineral nitrogen availability in comparison with a treatment having a high level of mineral nitrogen In this type of experiment the two treatments are denominated "without nitrogen" or "low nitrogen" (-N), and "with nitrogen" or "high nitrogen" (+N) respectively

In Stage 2 and Stage 3 experiments, the same two treatments are used but treatments with inoculants are included as well In this case the uninoculated treatments with low and high mineral nitrogen availability are used as controls and are denominated "uninoculated" (-I) and "with nitrogen" (+N) The inoculated treatments are called "inoculated" (+I) or given a number if more than one is included, obviously these treatments are established under conditions of low mineral nitrogen availability

For more detailed information on the objectives of the evaluation stages and their respective treatments refer to the study guide of the CIAT audiotutorial unit on this subject

### 1 3 Examples of use of the evaluation stages of the symbiosis in tropical forage legume and bean selection programs

The effectivity of the legume-rhizobium symbiosis is an important component of legume yield. For this reason, the selection of effective legume-rhizobium combinations using either inoculated or native strains, should be integrated in legume selection programs which use yield as a selection parameter.

The germplasm flow-steps of each particular legume selection program may bear a different relationship to the evaluation stages shown in Figure 1 1.

Yield should not be used as a selection parameter before carrying out Stage 1<sub>L</sub>. Ideally, the first yield evaluations would be equivalent to Stage 1<sub>L</sub>. However, in some cases this is not possible because too many accessions are being evaluated at this stage. In these cases legume-rhizobium evaluations are carried out in parallel to the main yield evaluation trials, yield trials are fertilized with N, or inoculated with the best rhizobium strain available, although the use of only one treatment in yield trials is not advisable.

#### 1 3 1 Selection of tropical forage legumes

The methodology used by the RIEPT (International Network for Evaluation of Tropical Pastures) coordinated by CIAT to evaluate tropical forage legumes, includes four germplasm flow steps: regional trials A, B, C, and D (Table 1 2).

Table 1 2 Evaluation sequence of forage legumes in the RILEPT

Regional trial	Evaluation criteria <sup>a</sup>	Introductions per site (no )
RTA	Biological characterization	More than 100
RTB	Yield, cutting and persistence in monoculture with no grazing	30 - 40
RTC	Persistence and compatibility with grasses under grazing	5 - 10
RTD	Animal production	Less than 5

a For more detailed information consult CIAT, 1982a

Inoculants are not applied in the RTA, because these experiments include many accessions whose inoculation requirements are not yet known. If the plants show lack of vigor or chlorosis, they are fertilized with nitrogen.

Materials planted in the RTB should be inoculated with the best strains available, but if lack of vigor or chlorosis is observed they should also be fertilized with nitrogen. Yield should not be emphasized as a criterion for selection at this stage.

The RTA and RTB are equivalent to "previous legume selections" in the flow diagram (Figure 1 1). Where possible, a Stage 1<sub>L</sub> type experiment should be set up with all the accessions evaluated in the RTB, in order to detect problems which may occur due to lack of adaptation of the recommended strains to local conditions.



With materials selected from these preliminary trials, Stage 2 experiments should be carried out before setting up RTCs and RTDs, so that locally adapted strains can be used in these subsequent trials. Where Stage 2 experiments show that inoculation is not necessary, materials of RTCs and RTDs need not be inoculated. This strategy is shown in Figures 1 2 and 1 3

However, at some sites Stage 2 experiments have not been carried out before setting up the RTCs and RTDs. A "need to select strain" experiment should be carried out at these sites in parallel to or preferably before setting up the RTDs (Figure 1 4). In these cases, materials in the RTC and RTD are inoculated with the best available strain, whose adaptability to local conditions is only determined when the best materials are already available for release and possible commercial use. This implies a certain risk of eliminating legumes due to lack of adaptation of the inoculants used to local conditions, and of not having the best strains available when the legume is released.

Appropriate inoculants should be delivered simultaneously with the legumes being released, rather than after the legume is already being used by farmers.

### 1 3 2 Selection of bean lines

The following scheme is used for selection of bean lines from CIAT. All lines selected in the breeding programs enter the "bean team nurseries" (VEF) where adaptation, pest and disease resistance, etc. are evaluated. Selections from the VEF then enter the "preliminary yield trials" (EP), where yield is the primary selection criterion. Thus it is recommended that the EP be carried out with two treatments (low N uninoculated and high N). This type of experiment would correspond to Stage 1<sub>L</sub>.

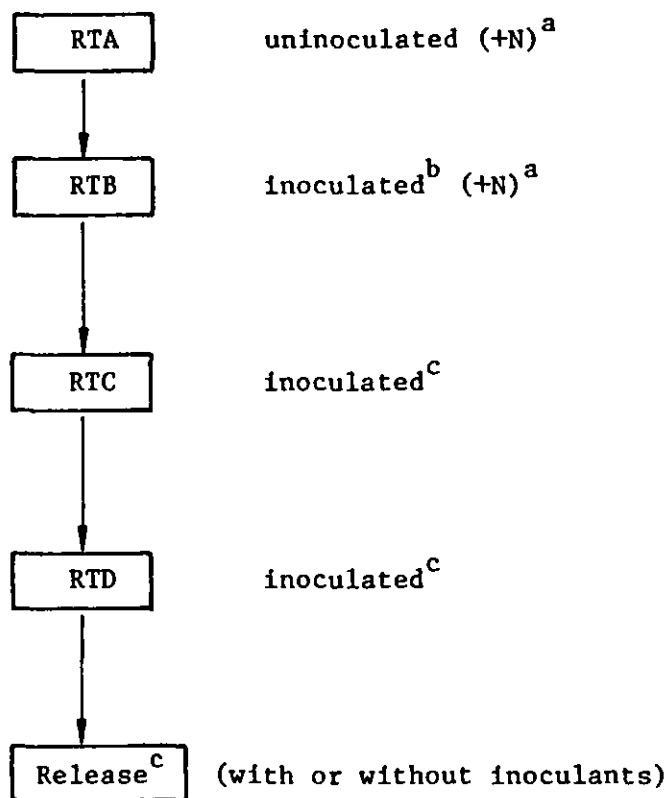

- a Fertilized with nitrogen when lack of vigor or chlorosis are observed
- b With a strain recommended and supplied by CIAT or other institution
- c Inoculated where necessary with strains selected in parallel experiments under local conditions

Figure 1 2 Strategy recommended for trials carried out in the RIEPT

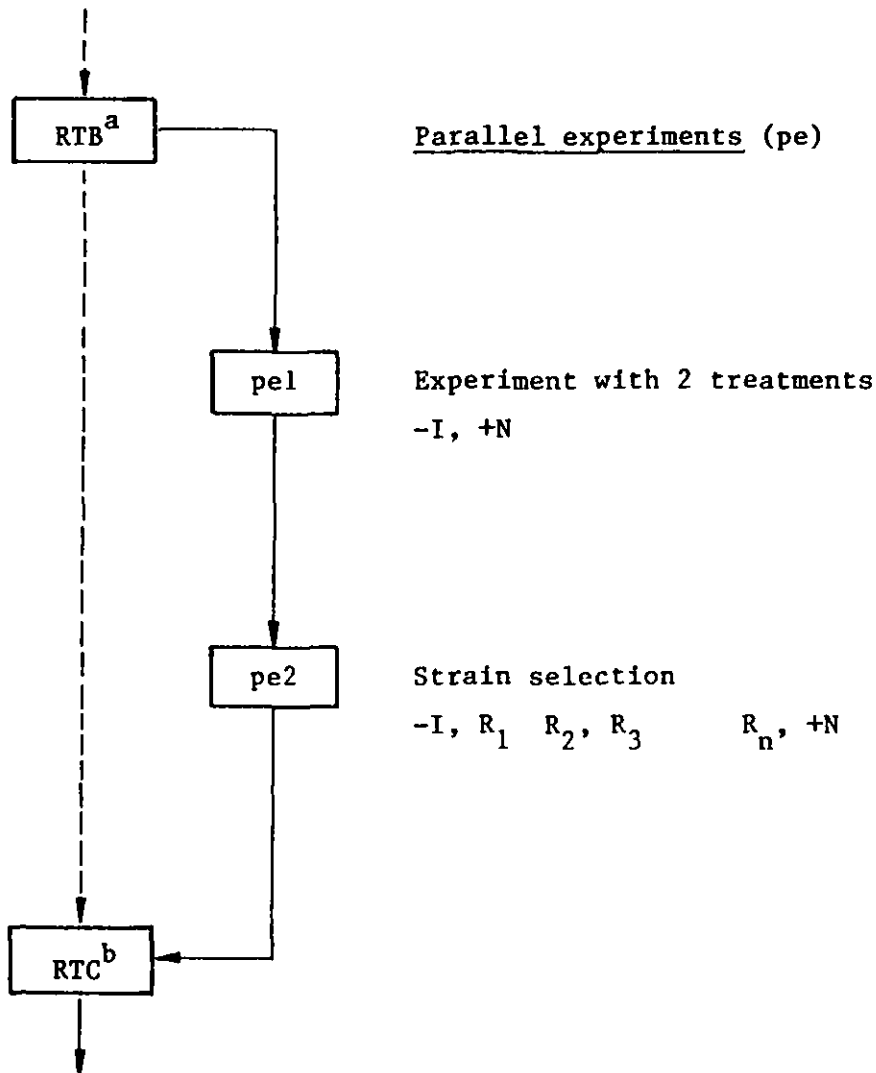

a Inoculated, also, fertilized with N if chlorosis or a lack of vigor is observed

b Inoculated where necessary with strains selected in parallel experiments under local conditions

I = inoculation, N = nitrogen, R = rhizobium strain

Figure 1 3 Strategy recommended for parallel rhizobiology experiments to be carried out before setting up the RTC's

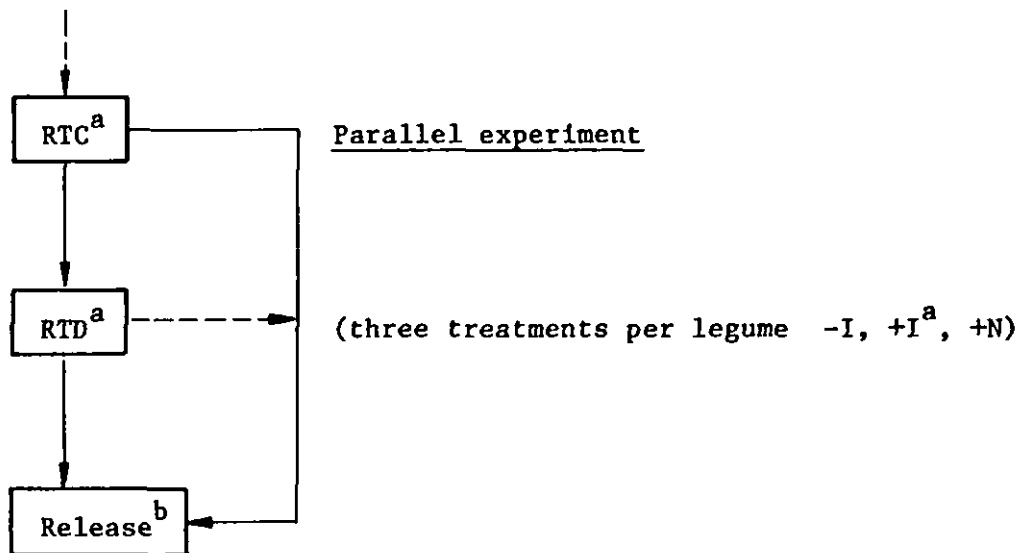

- a Inoculation with a recommended strain from another institution
- b With or without inoculant, depending on the results of the parallel experiment

Figure 1 4 Strategy for parallel experiments to those of the RIEPT, where it is not possible to follow the strategy recommended in Figure 1 3

However, not all programs can evaluate the EP using two treatments, more often high or medium N levels are used. This means that no information on  $N_2$  fixation is obtained, there is a risk of eliminating materials with the best  $N_2$ -fixing capacity, and those materials that are selected may require N fertilization. Materials selected in the EP are evaluated in International Bean Yield and Adaptation Nurseries (IBYAN). This stage would be most appropriate for carrying out "need to select strain" experiments (Stage 2).

Each country has its own scheme for evaluating bean lines. Some follow the VEF-EP-IBYAN scheme while others do not. For example at the Instituto de Ciencia y Tecnología Agrícola (ICTA) Guatemala, on-farm trials are carried out at an early stage. Selections from the breeding program ( $F_4$  and  $F_5$ ) and materials from other countries go to preliminary yield trials (EPRs) with approximately 50 entries. These EPRs are carried out on experimental stations and when the quantity of seed permits, this would be the ideal time to include the two treatments used in Stage 1.

Approximately 15 materials are selected from the EPR for on-farm trials at about 20 sites. These trials are maintained by trained personnel and at present are fertilized with 40 kg N/ha. It would be useful to carry out "need to select strain" experiments at some of these sites, with defined N levels (Stage 2).

From these experiments some materials are selected for large scale verification plots which are managed by the farmers. Where yield increases due to inoculation have been observed in Stage 2 these verification plots should be inoculated with the most effective strains.



## 2 NODULE COLLECTION FOR RHIZOBIUM ISOLATION

Root nodules of legumes vary in shape (round, long, or branched) and in size (0.5 to 50 mm in diameter) but the nodules can always be easily detached from the root. The internal color of active, living nodules varies from pink to dark red. The structure is firm and when the nodule is opened, a red sap is discharged from the tissue. A dead nodule is more spongy and the internal color is dark to black. Living nodules which are green or white on the inside are inactive, red or pink nodules are not always active, but are more likely to be so.

The location of nodules on the root system depends on the species of host plant and environmental conditions. Under some conditions the nodules are located far from the crown, sometimes they are very deep, or they may be found only on the lateral roots. In the majority of species of agronomic importance, however, nodules are found on the tap root and can be collected by carefully digging up the plant with a pocketknife or shovel. It is not advisable to pull the plant out, because this is likely to break the fragile connection of the nodules to the roots and most of the nodules will remain in the soil.

To collect nodules from which rhizobia are to be isolated, excavate a vigorous plant with healthy, green leaves. Always identify the plant by its scientific name, if this is not known, collect leaves, flowers, and seeds to identify it later. Try to synchronize collection dates with the season of vegetative growth when the nodules are most active and abundant (usually the wet season). It is often more convenient, however, to use seed collection trips for also collecting nodules, usually these are undertaken during the dry season. When there are no nodules on the roots of the plants examined, collect a small amount of soil (5 g) from around the roots. Inoculate a plant growing in sterile sand and nutrient solution with this soil, to induce the formation of nodules by rhizobia from the original collection site.

For preservation, between 10 and 20 intact, living nodules should be chosen and put with the attached roots in a glass bottle or tube that

contains anhydrous calcium chloride or dry silica gel as shown in Figure 2.1. Whenever possible, all the nodules in a tube should originate from a single plant. If the nodules come from various plants this should be recorded on the information sheet that accompanies them. If the sample of nodules is large, divide it between several tubes. The tubes should be taken to the field, because the rhizobia decompose unless the nodules are dried rapidly.

It is best to leave a small piece of root attached to the nodules to facilitate manipulation during the isolation procedure. Close the tube tightly to permit the drying process to begin. If water condenses inside the tube or the silica gel changes color the nodules should be transferred to another tube. If the rhizobia cannot be isolated immediately it is best to store the dried nodules in the refrigerator so that the rhizobia remain viable longer.

Once collected, the nodules can be sent to the CIAT soil microbiology laboratories, or to other laboratories that have facilities for isolating bacteria. Nodules sent from another country cannot be accepted by CIAT unless the package is accompanied by a phytosanitary certificate. This certificate can be requested from CIAT in advance. Also, the form at the end of this chapter should be completed and sent with the nodules. It is extremely important to record as much information as possible regarding all nodule samples collected.



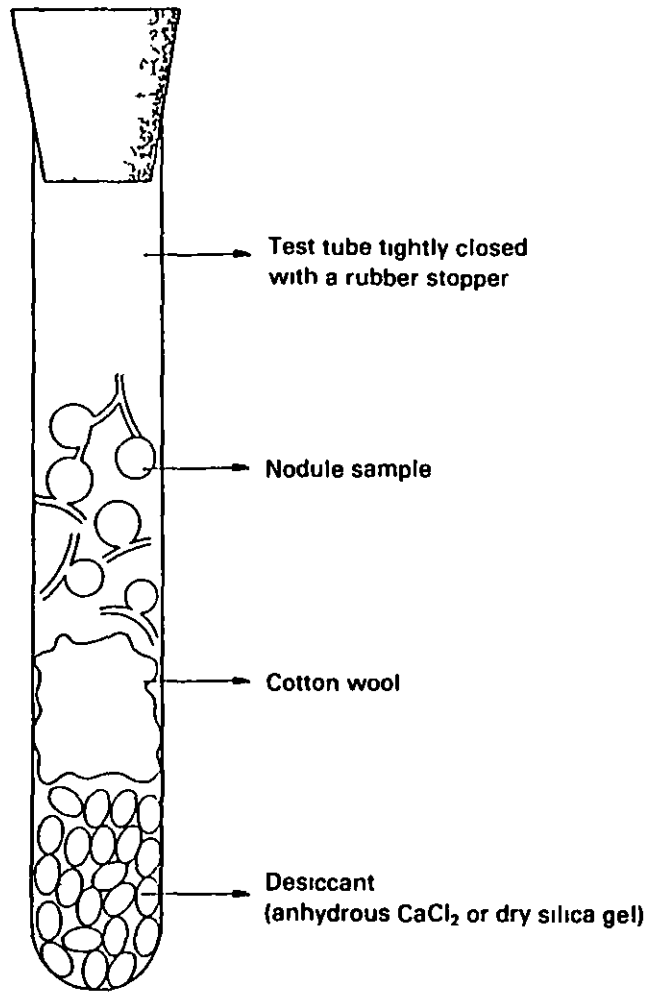

Figure 2 1 Preservation of nodules in a test tube with desiccant

Nodule Collection  
Information Sheet

1 General Information

1 1 Date of collection \_\_\_\_\_  
1 2 Collection site Country \_\_\_\_\_ State \_\_\_\_\_  
Town \_\_\_\_\_ Farm \_\_\_\_\_  
1 3 Climate Rainfall \_\_\_\_\_ mm Mean temperature \_\_\_\_\_ °C  
Elevation \_\_\_\_\_ Seasonal pattern \_\_\_\_\_  
1 4 Collector's name \_\_\_\_\_  
1 5 Collector's address \_\_\_\_\_  
1 6 Name of the plant scientific name \_\_\_\_\_  
common name \_\_\_\_\_

2 Collection Site

2 1 \_\_\_ Trial Inoculation trial \_\_\_\_\_ Another trial \_\_\_\_\_  
2 2 \_\_\_ Cultivated field Monoculture \_\_\_\_\_ Intercropped with \_\_\_\_\_  
2 3 \_\_\_ Crop age \_\_\_\_\_ Background of site \_\_\_\_\_  
2 4 \_\_\_ Pasture with introduced legumes \_\_\_\_\_ with native  
legumes \_\_\_\_\_  
2 5 \_\_\_ Native savanna Well drained \_\_\_\_\_ Poorly drained \_\_\_\_\_  
Open savanna \_\_\_\_\_ With bushes \_\_\_\_\_  
With trees \_\_\_\_\_  
2 6 \_\_\_ Forest seasonal \_\_\_\_\_ evergreen \_\_\_\_\_  
2 7 \_\_\_ Flooded area \_\_\_\_\_  
2 8 \_\_\_ Roadside \_\_\_\_\_  
2 9 \_\_\_ Other relevant information \_\_\_\_\_  
\_\_\_\_\_  
\_\_\_\_\_

3 Soil Characteristics

3 1 pH Estimated \_\_\_\_\_ Measured \_\_\_\_\_  
3 2 Soil humidity Estimated \_\_\_\_\_ % Measured \_\_\_\_\_  
3 3 Texture \_\_\_\_\_  
3 4 Natural fertility High \_\_\_\_\_ Medium \_\_\_\_\_ Low \_\_\_\_\_  
3 5 Fertilizers applied \_\_\_\_\_ Rate \_\_\_\_\_/ha  
\_\_\_\_\_ Rate \_\_\_\_\_/ha

4 Plant and Nodule Characteristics

4 1 Plant Uninoculated \_\_\_\_\_ Inoculated \_\_\_\_\_ with strain no \_\_\_\_\_  
Specially vigorous and green, Yes \_\_\_\_\_ No \_\_\_\_\_  
Availability of seed for experiments Yes \_\_\_\_\_ No \_\_\_\_\_  
4 2 Nodules From a single plant \_\_\_\_\_ From two or more plants \_\_\_\_\_  
Abundance High \_\_\_\_\_ Medium \_\_\_\_\_ Low \_\_\_\_\_  
Characteristics Size \_\_\_\_\_ Internal color \_\_\_\_\_  
Shape \_\_\_\_\_ Distribution \_\_\_\_\_  
4 3 Other relevant information \_\_\_\_\_  
\_\_\_\_\_  
\_\_\_\_\_  
\_\_\_\_\_

### 3 ISOLATION OF RHIZOBIA FROM NODULES

- 3 1 If the rhizobia are not to be isolated immediately after nodule collection, they should be stored in glass tubes containing desiccant (see Chapter 2)
- 3 2 If isolating from dried nodules, soak them in sterile water for 1 to 2 hours to rehydrate them and loosen adhered dirt (Figure 3 1)
- 3 3 The surface sterilization of nodules can be carried out in Petri plates, on ceramic plates with small depressions, or in open-ended glass tubes with one end covered with gauze (see Figure 3 1) First submerge the nodules in 95% alcohol for approximately one minute Then put them in a disinfectant solution which may be  $H_2O_2$  (3%-5%) a 0.1% solution of  $HgCl_2$ <sup>1</sup> or 3% Na hypochlorite for 3-4 minutes shaking occasionally Less time is needed for smaller nodules, since the sterilizing solutions may kill the rhizobia Wash the nodules five times in sterile water
- 3 4 Take previously prepared Petri plates containing yeast mannitol agar (YMA)<sup>2</sup> The pH and indicator used in the YMA depends on the species of legume and on the conditions under study If work is being done with Bradyrhizobium sp for tropical forage legumes, it is recommended that YMA pH 5.5 (with bromocresol purple) and YMA pH 6.8 (with bromothymol blue) be used Fast-growing rhizobia which produce acid may be streaked on YMA pH 6.8 (with Congo red or bromothymol blue as an indicator)
- 3 5 To isolate rhizobia from a surface sterilized nodule, squash the nodule in a drop of sterile water in a Petri plate containing YMA Alternatively, the nodule may be cut open with a sterile scalpel and the substance from inside the nodule placed on the Petri plate with a sterile toothpick The contents of one nodule are streaked

---

1 The  $HgCl_2$  solution at 0.1% is prepared as follows 1 g of  $HgCl_2$  5 ml of concentrated HCl and 1 liter of sterilized  $H_2O$

2 See medium preparation at the end of this chapter

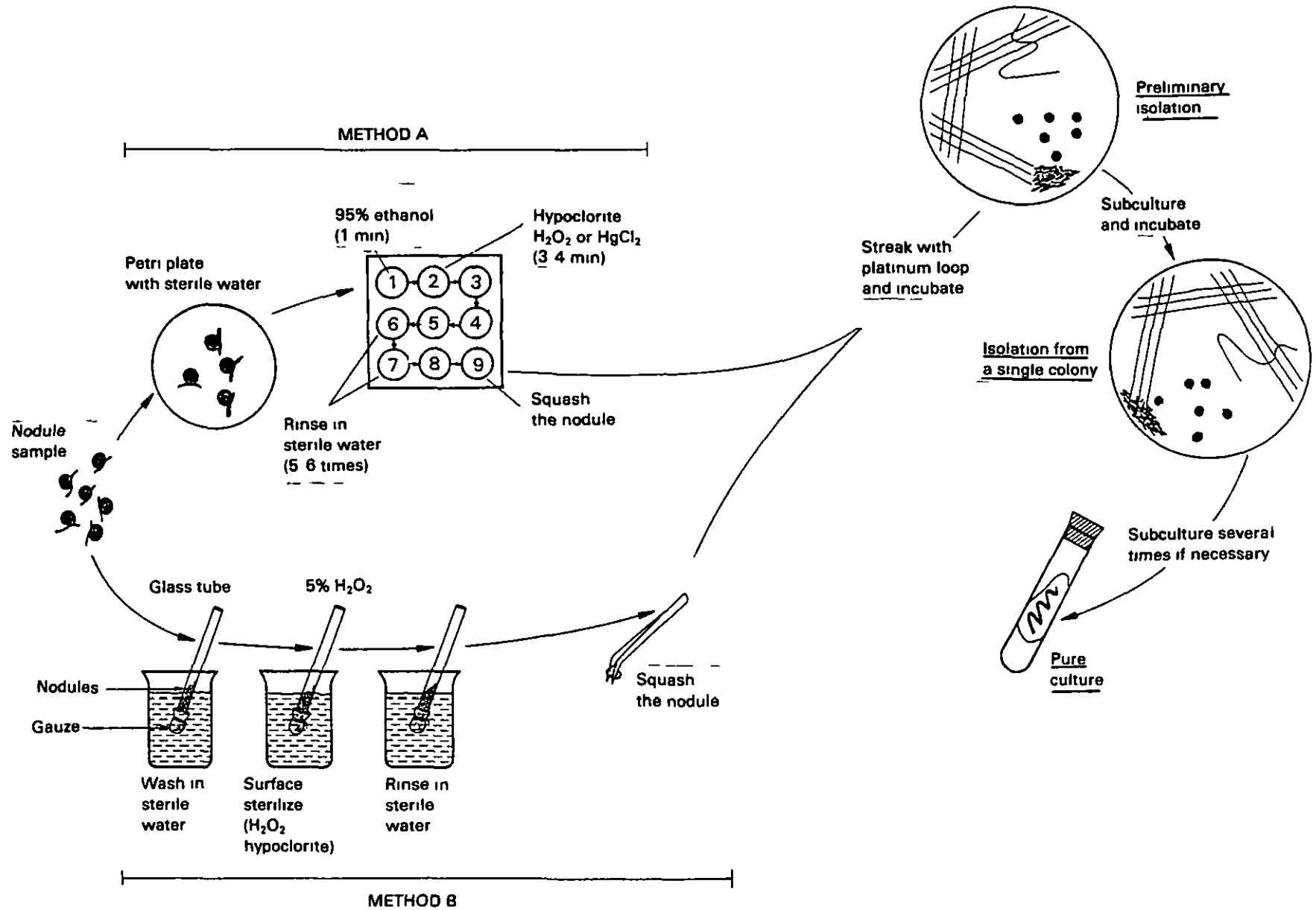

Figure 3 1 Procedure for isolation of rhizobia from nodules (2 methods)

on the medium in two Petri plates using a platinum loop (see Figure 3 2), a loop of chrome nickel alloy (commercial names "Nichrome" and "Chromel") is much cheaper, and can also be used. Another alternative is to cut open the nodule with a sterile scalpel and then transfer material from the center of the nodule to a Petri plate using a sterile toothpick. The streak plate method should result in at least five well-isolated colonies each of which originate from a single bacterium. A more secure means of obtaining isolated colonies is to suspend the squashed nodule in 100 ml 0.1% peptone with 0.01% Tween 40, shake well, transfer 0.1 ml to a Petri plate containing YMA, and spread (Figure 3 2).

- 3 6 Invert the plates so that condensed water does not drop onto the agar surface, and incubate at 28 °C. Colonies of fast-growing rhizobia appear within 2-5 days, while the colonies of slow-growing rhizobia appear within 5-15 days. For an adequate characterization of the colonies of slow-growing rhizobia, incubation for 15-25 days is required. It is necessary to examine the plates frequently, because those contaminated with fungi may infect the others, and should be eliminated immediately.
- 3 7 Pick single colonies most typical of rhizobia (see Chapter 5) and subculture them several times to purify the strain. Contaminants may appear before some slow-growing rhizobia. One nodule may contain more than a single rhizobium strain, also in some cases one strain may form two colony types. Thus it may be necessary to subculture several colonies from each nodule (see 5 4).
- 3 8 After individual colonies have been subcultured 3-4 times, homogenous growth will be seen in the majority of strains, and the strain can be considered free of contaminants. However, to be sure of the purity of a strain it is necessary to use the spread plate method because many more isolated colonies are obtained than by the streak plate method. An individual colony is suspended in YM broth or in 0.1% peptone solution containing a detergent (Tween 40 at 0.1 ml/l, or 1% Calgon<sup>1</sup>) and glass beads or sand. Shake well, prepare a dilution series and

---

1 Na hexametaphosphate

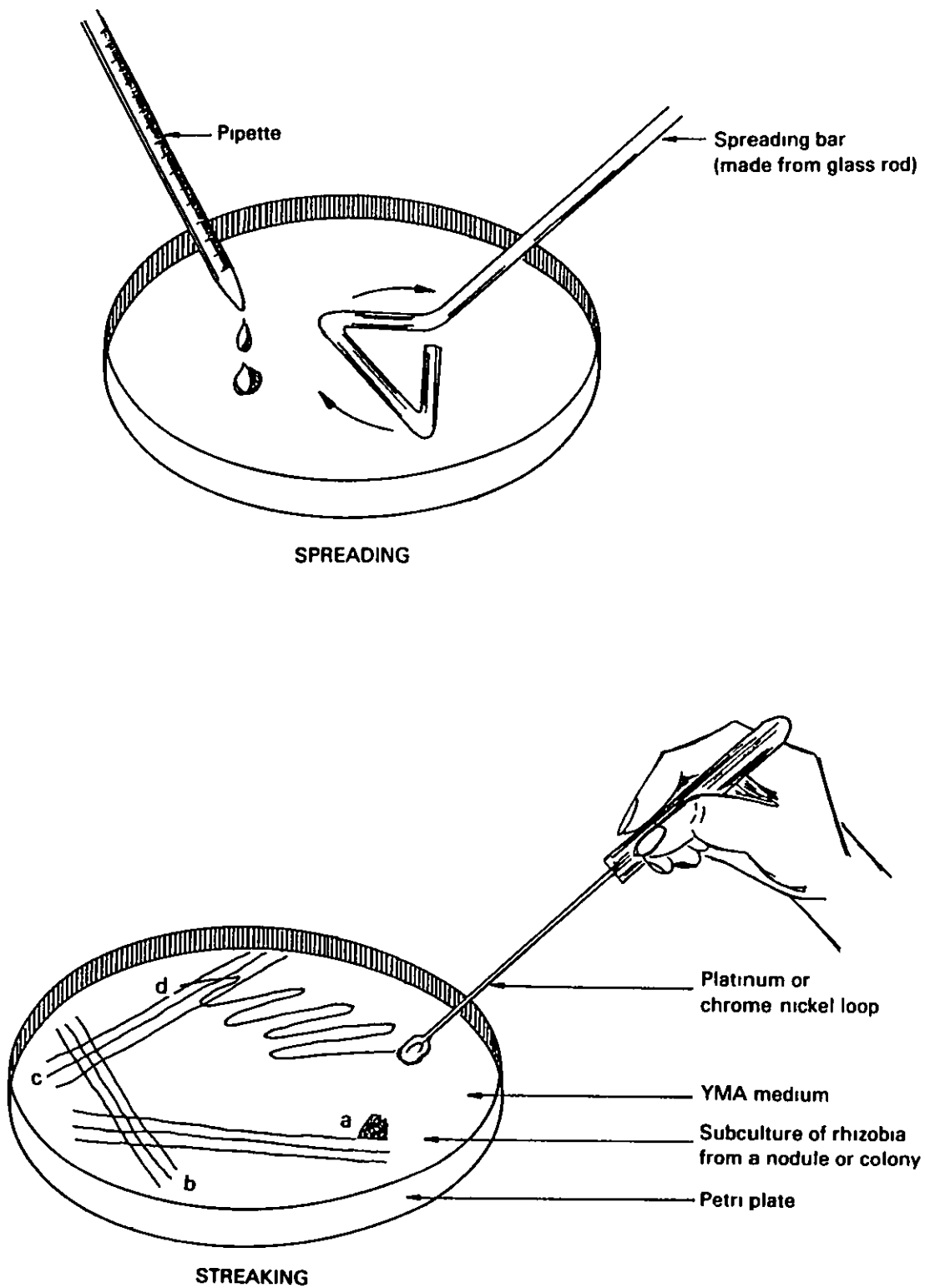

Figure 3 2 Spreading (above) and streaking (below) nodule contents on yeast mannitol agar Before streaking at points a, b, c, and d, sterilize the loop in a flame

plate using a spread bar (Figure 3 2) With a whole 7-day-old colony of Bradyrhizobium or 3-day-old colony of Rhizobium use  $10^3$  to  $10^6$  dilutions and transfer 0.1 ml/plate If the strain has two colony types, suspend both types separately and determine the proportion of each type on each plate This procedure is repeated several times, and if the two colony types persist the strain can be considered to be dimorphic This is a constant characteristic of some Bradyrhizobium strains

3 9 A strain that is difficult to purify can be inoculated onto a sterile plant (Siratro (Macroptilium atropurpurem), or other legume) The strain is reisolated from the nodules formed, this reisolation may help to eliminate the contaminants

### 3 10 Yeast Mannitol Agar (YMA)

3 10 1 Ingredients (Table, see next page)

#### 3 10 2 Preparation

Boil, shaking occasionally, to dissolve the agar and then sterilize in the autoclave Correct the pH to 6.8 with 0.8 to 1.0 ml of sterile NaOH (0.5 N), or acidify with approximately 1.7 ml of sterile HCl (1.0 N) for pH 5.5 The medium is acidified after sterilizing because the acidity combined with the high temperature causes the agar to decompose, for the same reason more agar is used in acid media

### 3 10 1 Ingredients

Mannitol	10 0 g
Yeast water <sup>1</sup>	100 0 ml
or yeast extract <sup>2</sup>	0 5 g
$K_2HPO_4$	0 5 g
$MgSO_4 \cdot 7H_2O$	0 1 g
NaCl	0 2 g
$FeCl_3 \cdot 6H_2O$	0 01 g
$CaCl_2$	0 15 g
Agar (Difto-Bacto) <sup>3</sup>	
in neutral media	15 0 g
in acid media	20 0 g
pH indicator solution <sup>4</sup>	5 0 ml
or Congo red solution <sup>5</sup>	10 0 ml
Complete with distilled water to a volume of	1000 0 ml

- 
- 1 To prepare yeast water mix 600 g of yeast (Fleischmann) with 5400 ml water and boil 1 hour in the autoclave without pressure. Leave to cool, and centrifuge (if centrifuge is not available, allow to settle 2-3 days in the refrigerator). Fill flasks of 100 ml with the supernatant, and store without sterilizing in the freezer.
  - 2 Yeast extract cannot be kept in very humid climates without spoiling, so for these situations yeast water is recommended.
  - 3 For liquid media do not add agar.
  - 4 0 5% bromothymol blue in 0 016 N NaOH (pH 6 8)           BTB  
0 5% bromocresol purple in 0 016 N NaOH (pH 5 5)       BCP  
0 3% bromocresol green in 0 016 N NaOH (pH 4 5)       BCG
  - 5 Aqueous solution of Congo red 1 g/400 ml of  $H_2O$



3 10 3 If large quantities of media are frequently used, it is useful to prepare stock solutions of some of the reagents

Stock solution	Reactants	Concentration g/l	ml/l of medium
A	$K_2HPO_4$	50	10
B	$MgSO_4 \cdot 7H_2O$ NaCl	10 20	10
C	$CaCl_2$	15	10
D	$FeCl_3 \cdot 6H_2O^a$	10	1

a Five drops of 1N HCl are added to maintain iron in solution

To prepare 1 liter of medium, mix 10 ml of solutions A, B, and C and 1 ml of solution D with the mannitol yeast water and distilled water (as described in 3 10 1)

3 10 4 Fungicides are useful in plates used for isolations from nodules and counts of samples that may contain some fungi. However when the sample contains many fungi the fungicide is insufficient to inhibit them. Nistatin, actidione, and PCNB should be filter sterilized and added after the medium is autoclaved and allowed to cool to 50 °C. Alternatively they may be dissolved in sterile water, but in this case they should be used immediately. Use one of the following fungicides at the indicated concentration. The brilliant green solution can be added before autoclaving the medium. This fungicide cannot be used with a pH indicator.

Fungicide dosis per liter of YMA medium

1	Nistatin Commercial name Mycostatin	0 05 g/1
2	Actidione	0 1 g/1
3	PCNB (Brassicol)	0 1 g/1
4	Brilliant green solution (1 g/100 ml)	1 0 ml/1

3 10 5 Dispensing of medium into Petri plates and tubes

To prevent excessive condensation it is necessary to allow the medium to cool to about 50 °C before dispensing it into the sterile plates. The agar solidifies at 44 °C. The plates should be poured a day before they are to be used in order to allow them to dry out a little. Each glass plate contains 30-40 ml of medium (25 ml in the case of plastic disposable plates). Take precautions to avoid contamination while pouring.

Medium is dispensed into test tubes before sterilizing, or the empty tubes are sterilized and sterile medium is dispensed using a special sterilizable syringe. In the case of dispensing acid medium into tubes before sterilizing, it should be acidified after boiling (this helps to prevent decomposition of the agar).

## **4** STORAGE AND RECONSTITUTION OF RHIZOBIUM STRAINS

Rhizobium strains need to be preserved in such a way as to prevent contamination, mutation or death. Three storage methods are presented in this chapter: cold storage in tubes, desiccation on porcelain beads, and lyophilization (freeze-drying). In this order the first is the simplest and the last the most complex. The time over which the strains can be kept in a stable and viable condition also increases in the same order.

### **4 1** Storage in test tubes containing YMA slants

For short-term storage of rhizobia and to maintain working collections, it is recommended that pure strains be cultured in screw-capped test tubes containing slants of YMA. This method enables storage in the refrigerator for 2-3 months. The tube must be tightly closed to avoid drying of the agar. In addition, sterile mineral oil can be added to cover the agar surface and prevent drying.

### **4 2** Rhizobium storage on porcelain beads

Where freeze-drying facilities are not available, a good alternative for long-term storage is to dry cultures on porcelain beads (Norris and Date, 1976). These cultures have a 3-year storage life and are best kept at 4 °C. The procedure is as follows:

**4 2 1** Place 3-5 g of silica gel in 15 ml tubes with rubber-lined screw caps, or rubber bungs. A 1-2 cm layer of glass wool is put on top of the silica gel and then 8-10 unglazed porcelain beads (electrical insulators work well) are added.

**4 2 2** The tubes with silica gel and glass wool are capped with aluminum foil in a hot air oven (160 °C) for 2 hours. The rubber-lined caps or rubber bungs are sterilized by autoclaving (dry heat damages rubber).

4 2 3 A further set of test tubes, containing 0.1 g maltose and plugged with cotton wool, is prepared and autoclaved. One ml of culture suspension is added to these tubes and the maltose is dissolved by gentle shaking. The porcelain beads are added aseptically and the tube is shaken to absorb the suspension evenly onto the beads. The tube is inverted to drain excess liquid onto the cotton wool plug, then the beads are returned to the silica gel tube, which is sealed tightly. The culture will lose viability if the silica gel changes from blue to pink.

4 2 4 To reconstitute the cultures, one bead is removed with a sterile wire or needle and placed in liquid medium or inoculated onto (streaked across) a Petri plate containing YMA.

#### 4 3 Lyophilization

The most frequently used long-term storage method for rhizobium strains is freeze-drying. The rhizobia are suspended in peptone-sucrose solution (10% and 20% respectively, sterilized separately and mixed) and are freeze-dried in sterile labelled ampoules. The ampoules are vacuum sealed and can be kept indefinitely. To reconstitute lyophilized cultures, the following method is used.

4 3 1 Using a file, break the ampoule in the center of the cotton stopper, and flame the mouth of the tube over a burner.

4 3 2 Add approximately 3 drops of 0.1% peptone or other sterile broth with a Pasteur pipette, and mix in the ampoule. Try to bathe the walls of the tube with the solution to moisten all the cells that are in the ampoule.

4 3 3 With the Pasteur pipette, extract the solution from the ampoule and place one drop in each of two Petri plates containing YMA medium. YMA pH 6.8 and YMA pH 5.5 are recommended for strains from tropical forage legumes. YMA pH 6.8 is recommended for

fast-growing strains (from beans, for example), using one plate with BTB and the other with Congo red

4 3 4 Streak the culture across the plates using a platinum or nickel-chrome loop

4 3 5 Incubate at 28 °C Wait 10 days to allow good growth of Bradyrhizobium Note however, that there are some strains that take 15 days or more to grow With fast-growing rhizobia, good growth is attained after 3-5 days



# 5

## CHARACTERIZATION OF RHIZOBIA

- 5 1 Generally rhizobia do not absorb Congo red when the plates are incubated in the dark. The colonies remain white and opaque, or occasionally pink (the reaction depends however, on the correct concentration of Congo red and the culture's age). Many contaminating organisms absorb the red dye and can thus be distinguished from the rhizobia.
- 5 2 Plates of YMA pH 6.8 with BTB are green in color. Slow-growing rhizobia produce alkali and the medium becomes blue, whereas fast-growing rhizobia produce acid and the medium becomes yellow. YMA pH 5.5 containing BCP is khaki colored. Alkali production causes a deep purple color and acid production causes a change to yellow.
- 5 3 Colony characteristics change with time and conditions of incubation. Their texture may be buttery or elastic, and is determined by touching a colony with a loop. Colony appearance may be gelatinous, dry or wet. Strains of Rhizobium leguminosarum biovar phaseoli form gelatinous colonies, whereas those of Bradyrhizobium sp. are more variable in appearance. In general the vertical section of the colonies is flat or rounded. Only a few strains have colonies with a conical or fried-egg shaped elevation.
- 5 4 Two examples of colony characterization methods are presented.
- 5 4 1 Description of the growth of Rhizobium leguminosarum biovar phaseoli

These are fast-growing rhizobia. On YMA pH 6.8 with BTB at 28 °C there is little variation in the appearance of colonies among rhizobia in this group. They all produce gum, that is they are gelatinous, not dry. Some produce less gum, and are more opaque (less translucent).

Diameter of isolated colonies at 48 h \_\_\_ 60 h \_\_\_  
72 h \_\_\_ 84 h \_\_\_  
Quantity of gum much \_\_\_ little \_\_\_  
Texture elastic \_\_\_ buttery \_\_\_  
Shape flat \_\_\_ rounded \_\_\_  
Change in pH produces much acid \_\_\_ produces little acid \_\_\_  
no change \_\_\_  
Appearance shiny (translucent) \_\_\_ opaque (less translucent) \_\_\_

Due in part to the variable production of poly- $\beta$ -hydroxybutyrate it may be easier to distinguish between strains when colonies are old, for example striking differences may be observed after 16 days at 20 °C



#### 5 4 2 Description of the growth of Bradyrhizobium spp

Bradyrhizobium strains form dry, wet or gelatinous colonies  
Gelatinous and wet colonies are translucent and dry colonies are opaque In vertical section the gelatinous colonies are raised and rounded Dry colonies are flat or occasionally conical Wet colonies are initially rounded and later become flattened, and spread out over the agar surface Colony appearance may vary with the initial pH of the medium The following categories have been devised to assist with colony description

- 1 Growth categories on YMA with initial pH 5.5 and 6.8, incubated 10-20 days at 28 °C (Table, see next page)



Category	Initial pH 5.5	Initial pH 6.8
V	Very slow growth, small or medium sized (0.5-5.0 mm), dry <sup>a</sup> or gelatinous colonies, with elastic or buttery consistency	Little or no growth at this pH
W	Small or medium (0.5-5.0 mm), dry colonies, elastic or buttery consistency at both pHs	
X	Gelatinous colonies of medium size (3-5 mm diameter) and buttery or elastic consistency at both pHs	
Y	Aqueous (wet) <sup>a</sup> colonies that produce a liquid gum at both pHs, although often more gum is produced at pH 5.5 than at 6.8	
Z	Wet colonies with liquid gum	Small, dry colonies, with buttery consistency

a Dry colonies remain circular and convex even when they touch each other , when wet colonies touch each other, they run together  Sinclair and Eaglesman (1984)

2 The change of pH in the growth medium is categorized as follows

N = No change

C = Produces alkali

A = Produces acid

CA = Initially produces alkali, then acid

NA = Initially no change then acid

NC = Initially no change, then alkali

3 The growth rate and appearance of the colonies can be characterized in five groups -, (+), +, ++, +++

5 5 Some cultures of rhizobia frequently show two colony types (colony dimorphism) With these cultures it is necessary to take special care to eliminate the possibility of contamination, respreading individual colonies of each type several times (see 3 8) Colony dimorphism does not necessarily affect the strain's ability to fix nitrogen Cultures with two colony types can be used for inoculation, if it is known that this is a characteristic of the culture and is not due to the presence of contaminants or stable mutants

5 6 After characterizing the colonies it is necessary to verify that the isolated strain is a rhizobium by inoculating sterile plants and observing whether they nodulate (see Chapter 9)

5 7 The genus Agrobacterium belongs to the family Rhizobiaceae and has many characteristics in common with the fast-growing genus Rhizobium A. tumefaciens is able to form nodules (tumors) on some legumes but does not fix N<sub>2</sub> The ketolactase test is used to differentiate between the two genera The procedure is as follows

- Streak the strain on YMA in which the mannitol has been replaced with the same concentration of lactose (10 g/l)

- After the growth appears, cover the agar surface with 10-15 ml of Benedict reagent

Benedict reagent

Solution A		Solution B	
Sodium citrate	17.3 g	CuSO <sub>4</sub>	1.73 g
Sodium carbonate	10.0 g	Distilled water	10.0 ml
Distilled water	60.0 ml		

Store the two solutions separately. When ready to use, mix the two solutions and bring to a volume of 100 ml with distilled water.

- The appearance of a yellow color after 10 minutes indicates the presence of Agrobacterium



# 6 PURITY TESTS FOR RHIZOBIUM CULTURES

Rhizobium cultures are easily contaminated. In all stages of rhizobium management the purity checks described here should be used. This is especially important in inoculant production.

## 6.1 Colony characteristics

The purity check most frequently used by rhizobiologists is the recognition of typical colonies of each strain. Each strain differs in appearance, and by repeated examination of the strains their individual characteristics can be recognized, so that the experienced worker can easily distinguish them from contaminants. It is necessary to allow Bradyrhizobium strains to grow for at least 10 days so that colonies are sufficiently developed for this procedure to be reliable.

## 6.2 Microscopic examination

Rhizobia are Gram-negative (although they can be Gram variable), motile bacilli, and do not produce spores. By Gram staining, or using phase contrast microscopy, bacteria morphologically distinct from rhizobia can be identified (spores, cocci, or Gram-positive bacteria).

### 6.2.1 Gram stain for rhizobia (Vincent, 1970)

#### 1 Reagents

##### A Crystal violet solution

crystal violet	10 g
ammonium oxalate	4 g
ethanol	100 ml
distilled water	400 ml

B	Iodine solution	
	iodine	1 g
	potassium iodide	2 g
	ethanol	25 ml
	distilled water	100 ml
C	Alcohol (iodinated)	
	iodine solution (B)	5 ml
	ethanol	95 ml
D	Counterstain	
	2 5% safranin in ethanol	10 ml
	distilled water	100 ml

## 2 Procedure

Spread a loopful of culture on a clean slide and allow to air dry

Fix the smear by passing once through a Bunsen flame

Stain with solution (A) for 1 minute

Rinse gently with water

Flood with iodine solution (B) for 1 minute

Decolorize with solution (C) for 1-5 minutes

Rinse with water

Counterstain with solution D for 1-5 minutes

Rinse with water and dry

Examine under oil immersion Gram-positive cells appear dark violet, Gram-negative cells are light red

### 6 3 pH

A final pH of less than 5.5 or greater than 8 in YM liquid medium indicates the presence of contaminants

### 6 4 Peptone-glucose medium

Rhizobia do not grow well in peptone-glucose medium, so if there is marked growth with a change in pH contaminants are present. Sometimes contaminants do not grow well in YM medium, and it is possible to mistakenly consider a culture pure, if only the one medium is used. Peptone-glucose medium is prepared as follows

glucose	5 g
peptone	10 g
agar	15 g
bromocresol purple (1.0% in ethanol)	10 ml
Complete with distilled water to a volume of	1000 ml
Final pH =	6.7

### 6 5 Growth on YMA

The broth used for inoculant production is streaked onto YMA in Petri plates and the colonies are examined. Although the inoculant is made immediately, and the colonies take some time to grow, it is possible to confirm its purity before using it.

### 6 6 Purification of contaminated strains

The procedures described in Chapter 3 should be followed to repurify a contaminated strain. A broth which was intended for making inoculants and which has become contaminated should be thrown away.

## 6 7 Serology

The presence of a known strain in a culture can be confirmed using serology. However, this does not guarantee the absence of contaminants (see Chapter 7).



# 7 IMMUNODIFFUSION TEST FOR DISTINGUISHING BETWEEN STRAINS

Serology can be used to distinguish between rhizobium strains. There are a number of serological methods available which vary in their specificity. The immunodiffusion method can be used to distinguish between groups of strains, but within each group variability may exist which cannot be detected using this method. However, this method is simple, does not require much equipment and may be useful in some studies for distinguishing between strains.

In strain selection experiments in the field it is advantageous to know that the strains used are different from each other. Antisera for strains which have been identified as being promising in the greenhouse but are serologically uncharacterized, can be prepared on request in the laboratories of NifTAL or CIAT. This characterization facilitates choosing of strains for each legume that are serologically different for subsequent field experiments.

## 7.1 Antigen preparation

Suspend a Petri plate culture of the rhizobium in 10 ml of saline solution (0.85% NaCl). Wash twice resuspending the pellet the second time in 1-5 ml of saline solution, depending on the quantity of growth of each strain. Place the tubes in a water bath for 30 minutes at 100 °C, to destroy the flagellar and capsular antigens.

## 7.2 Preparation of the plates

Add 1.2% agar to 0.85% saline solution. Melt the agar, cool and add 0.065% sodium azide to prevent growth of contaminants. Sodium azide decomposes at high temperatures. Pour the medium into disposable Petri plates to a depth of 4 mm, and then allow the medium to solidify. Make small cavities in the agar in a hexagonal pattern with a single cavity in the center (see Figure 7.1). This can be done with the appropriate Gelman equipment or a small cork-borer of 2-5 mm diameter.

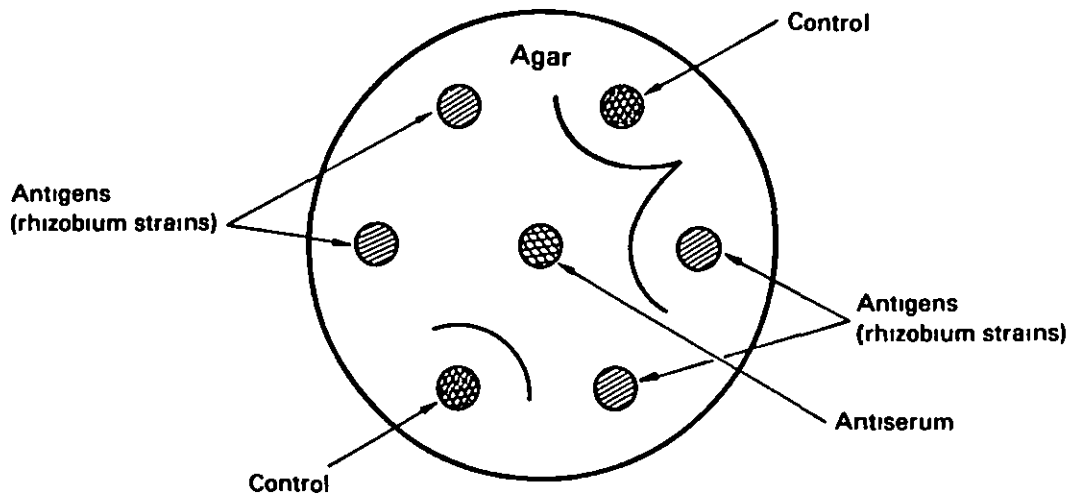

Figure 7 1 Immunodiffusion tests to differentiate between rhizobium strains

Fill the central cavity with antiserum, and fill the external cavities with the cultures to be tested (the antigens) Two of the external cavities should contain the same strain that was used to prepare the antiserum These two "control" cavities should be on opposite sides of the hexagon

### 7 3 Incubation and interpretation of the results

Strains that are serologically complementary to the antiserum form precipitation zones contiguous with the zones formed by the controls The time needed for the formation of bands depends on the size of the cavities, the humidity and air temperature, and also on the specific antibody-antigen reaction If too much time passes, the bands can lose their clarity Therefore, it is best to observe the plates every day to ascertain the appropriate times of incubation under local conditions

# 8 ADDITIONAL CHARACTERISTICS OF RHIZOBIUM STRAINS

In certain cases the determination of additional characteristics may be useful to distinguish between strains or to identify strains that have desirable qualities. Some of the methods that can be used are described below.

## 8.1 Growth at various pH levels (4.5, 5.0, 6.8, and 9.0)

The adjustment of YMA to different pHs has already been discussed (see Chapter 3). Keyser medium, a defined medium, has been modified for screening bean strains for their tolerance to different pH levels at CIAT. The strains are spread on media of different pHs, and growth is evaluated using qualitative categories (-, +, ++, +++) or measuring the diameter of the colonies. For quantitative data, the number of viable cells per colony can be determined using plate counts.

### 8.1.1 CIAT modification of Keyser medium (Keyser 1978, Keyser and Munns, 1979)

#### Stock solutions

##### 1. Micronutrients

MnCl <sub>2</sub> · 4H <sub>2</sub> O	0.504 g
ZnSO <sub>4</sub> · 7H <sub>2</sub> O	0.227 g
CuCl <sub>2</sub> · 2H <sub>2</sub> O	0.034 g
NaMoO <sub>4</sub> · 2H <sub>2</sub> O	0.008 g
Distilled water to	1000 ml

## 2 Vitamins

Thiamine HCl	0 400 g
d-Pantothenic acid (Ca)	0 400 g
Biotin	0 0001 g
Distilled water to	100 ml

## 3 Phosphate

$\text{KH}_2\text{PO}_4$	1 36 g
Distilled water to	1000 ml

## Medium

Glycerol	5 ml
$\text{K}_2\text{SO}_4$	0 131 g
Na glutamate	0 220 g
$\text{MgSO}_4 \cdot 7\text{H}_2\text{O}$	0 074 g
$\text{CaCl}_2 \cdot 2\text{H}_2\text{O}$	0 007 g
Fe-EDTA	0 035 g
Micronutrient solution	0 5 ml
Vitamin solution	1 0 ml
Phosphate solution	1 0 ml
Distilled water to	1000 ml

Add 2% agar if desired Sterilize, then check the pH, and adjust to the desired level using sterile HCl or NaOH

## 8 2 Tolerance to high Mn levels

The concentration of Mn in Keyser medium pH 6 0 is increased to give 50  $\mu\text{M}$  (add 8 45 mg  $\text{MnSO}_4 \cdot \text{H}_2\text{O}$  per liter of medium)

### 8 3 Tolerance to high Al levels

$\text{AlCl}_3 \cdot 6\text{H}_2\text{O}$  is added to Keyser medium at pH 4.6 (after it has been sterilized) to give 2 and 4 ppm Al (17.9 mg/l and 35.8 mg/l)

### 8 4 Tolerance to high levels of NaCl

Add 1% or 2% NaCl to YMA

### 8 5 Temperature

Spread dilutions of rhizobia on YMA, then incubate the plates at different temperatures (e.g. 10, 15, 28 and 36 °C) and observe periodically for growth

### 8 6 Denitrification

Many slow-growing rhizobia are capable of anaerobic growth in the presence of nitrate and are capable of some denitrification. Denitrification has not been demonstrated in fast-growing rhizobia other than R. meliloti. Although not sufficiently sensitive to detect low denitrification activity (a gas chromatograph for  $\text{N}_2\text{O}$  analysis and  $^{15}\text{N}$  analysis for  $\text{N}_2$  are needed if very sensitive measures are required) the following method was used by Zablotowicz et al. (1978) to identify actively denitrifying rhizobia.

To assay for denitrification, culture tubes (16 x 150 mm) containing 10 ml YM liquid medium and an inverted Durham tube are used (a 5 x 40 mm tube inverted in the liquid medium, see Figure 8.1)

Sterilized  $\text{KNO}_3$  is added to half the tubes to give a concentration of 1 mg/ml. Plus and minus  $\text{KNO}_3$  tubes are inoculated with each strain to be tested. Tubes are tightly capped and incubated at 28 °C for 3-4 weeks. They are then examined for bacterial growth, gas production and, if possible, nitrate and nitrite concentrations are determined.

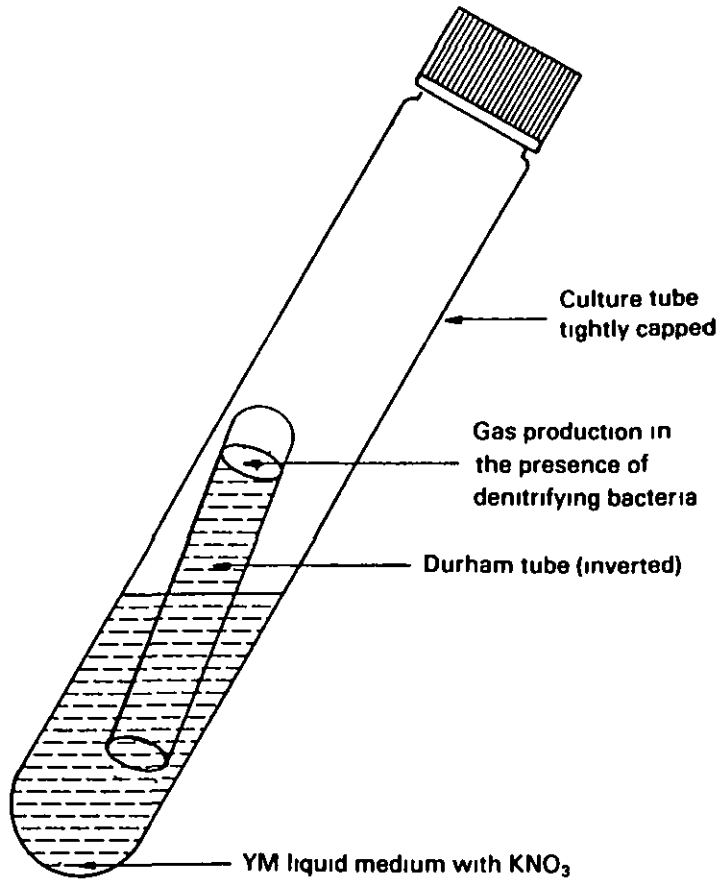

Figure 8 1 Evaluation of denitrification using nitrate medium with a Durham tube

8 6 1 Nitrate determination (Cataldo et al , 1975)

- Place 0.2 ml aliquots of the samples to be evaluated in 50 ml Erlenmeyer flasks. Flasks containing a range of known  $\text{NO}_3^-$  concentrations (between 5 and 300  $\mu\text{g NO}_3^-/\text{ml}$ ) are also included.
- Add 0.8 ml of 5% (w/v) salicylic acid in concentrated  $\text{H}_2\text{SO}_4$  to each flask.
- After 20 minutes at room temperature, 19 ml of 2N NaOH is added slowly to raise the pH above 12.
- Samples are cooled to room temperature and absorbance at 410 nm determined. The blank consists of sample,  $\text{H}_2\text{SO}_4$  (without salicylic acid) and NaOH.
- A standard curve is prepared using the known  $\text{NO}_3^-$  concentrations, this curve is used to determine the  $\text{NO}_3^-$  concentration in the samples.





# 9 PLANT INFECTION METHODS IN TEST TUBES, GROWTH POUCHES, AND LEONARD JARS

For counts and plant infection studies on pure rhizobium isolates it is necessary to grow plants under sterile conditions

For large-seeded legumes, such as beans and soybeans Leonard jars or growth pouches are recommended for authentication tests and counts. Smaller seeded legumes may be grown in tubes. In test tubes and growth pouches, nodulation is evaluated but not plant yield, in Leonard jars better plant growth permits yield evaluations to be made, although precautions must be taken to optimize plant growth conditions. To authenticate strains and for counts three to five replicates should be included, and some uninoculated controls.

Ideally, a rhizobium isolate should be tested for its ability to produce nodules on the plant species from which it was originally isolated. However it may be more convenient to substitute a different legume. Siratro nodulates with over 90% of the slow-growing rhizobia and is used for authenticating most slow-growing rhizobia from tropical pasture legumes (it cannot be used for some strains of soybean for chickpea, and some other legumes).

## 9 1 Seed sterilization and scarification

- 9 1 1 Seeds should be freshly harvested and of good quality. To maintain a good source routinely plant in pots and harvest the seeds. Old seed contaminates easily and the plants do not nodulate well.
- 9 1 2 Place the seeds in a tube or adequately sized flask (remember that the seeds will swell).
- 9 1 3 Cover the seeds with 95% ethanol and shake the tube for 3 minutes. Tip out the ethanol.

- 9 1 4 Cover the seeds with acidified  $\text{HgCl}_2$  (preparation 1 g of  $\text{HgCl}_2$ , 5 ml of concentrated HCl and distilled water to 500 ml), 3% sodium hypochlorite or 3% hydrogen peroxide can be used in place of the  $\text{HgCl}_2$  (which is very toxic) Wait for 3 minutes
- 9 1 5 Wash 5-6 times with sterile water then let the seeds soak in water for 1-2 hours
- 9 1 6 It may be necessary to scarify some hard-coated seeds, for example, Siratro Make a small cut in the testa of each seed with a sterile scalpel
- 9 1 7 Aseptically transfer the seeds to a Petri plate that contains one of the following 2 sheets of wet, sterile filter paper, potato dextrose agar (PDA), or 0.75% water agar
- 9 1 8 Incubate the seeds for 24-48 hours to permit germination For small-seeded species (less than 3 mm), the plates can be inverted to allow for the development of straight radicles
- 9 2 Media used in tubes, Leonard jars and growth pouches

The medium of Norris and Date (1976) is generally used for forage legumes that are sown in tubes Sandman's medium (1970) is used for beans and other large-seeded legumes that are generally sown in growth pouches or in Leonard jars However, sometimes it is also necessary to plant forage legumes in Leonard jars, in this case Norris and Date's medium is used in the jars If nutrient deficiencies or toxicities result it may be necessary to modify or use an alternative medium, for example, that of Jensen

9 2 1 Medium of Norris and Date (1976)

1 Prepare stock solutions

<u>Solution</u>	<u>Reagents</u>	<u>Concentration g/l</u>	<u>Stock solution (ml) per liter of medium</u>
A	KCl	29.8	2.5
B	K <sub>2</sub> HPO <sub>4</sub>	69.6 <sup>a</sup>	2.5
C	MgSO <sub>4</sub> · 7H <sub>2</sub> O	98.6	2.5
D	Micronutrients		0.5
	CuSO <sub>4</sub> · 5H <sub>2</sub> O	0.078	
	ZnSO <sub>4</sub> · 7H <sub>2</sub> O	0.22	
	MnSO <sub>4</sub> · 4H <sub>2</sub> O	2.03	
	(NH <sub>4</sub> ) <sub>6</sub> Mo <sub>7</sub> O <sub>24</sub> · 4H <sub>2</sub> O	0.01	
	H <sub>3</sub> BO <sub>3</sub>	1.43	
E	Ferric citrate	1.795	1.0

a For Stylosanthes spp the quantity of K<sub>2</sub>HPO<sub>4</sub> in the stock solution is reduced to 4.35 g/l

2 Take 2.5 ml of stock solutions A, B, and C, 0.5 ml of stock solution D and 1 ml of stock solution E to prepare 1 liter of medium

3 Add 0.344 g of CaSO<sub>4</sub> · 2H<sub>2</sub>O per liter of medium<sup>1</sup> This does not dissolve so it is important to mix well while dispensing into tubes or bottles

<sup>1</sup> For Stylosanthes pp the quantity of CaSO<sub>4</sub> · 2H<sub>2</sub>O is reduced to 0.068 g per liter of medium

- 4 Adjust the pH to 6.8 or 4.5 (with sterile NaOH or HCl) after autoclaving, if it is considered necessary. Without adjusting the pH, it is approximately 6.5 after autoclaving.

9.2.2 Sandman nutrient solution

1 Prepare stock solutions

A Iron

FeSO <sub>4</sub> · 7H <sub>2</sub> O	5.0	g
citric acid	5.0	g
distilled water to	1000	ml

B Micronutrients

CuSO <sub>4</sub> · 5H <sub>2</sub> O	0.157	g
ZnSO <sub>4</sub> · 7H <sub>2</sub> O	0.44	g
MnSO <sub>4</sub> · 7H <sub>2</sub> O	3.076	g
(NH <sub>4</sub> ) <sub>6</sub> Mo <sub>7</sub> O <sub>24</sub> · 4H <sub>2</sub> O	0.02	g
H <sub>3</sub> BO <sub>3</sub>	2.26	g
distilled water to	1000	ml

- 2 Medium preparation to 750 ml of distilled water add the following

KCl	0.149	g
MgSO <sub>4</sub> · 7H <sub>2</sub> O	0.493	g
K <sub>2</sub> HPO <sub>4</sub>	0.348	g
Iron solution	0.5	ml
Micronutrient solution	0.5	ml

- 3 Adjust to pH 6.7 after autoclaving (with sterile NaOH or HCl) if necessary

#### 4 Calcium solution

KNO <sub>3</sub>	0 2	g
CaSO <sub>4</sub>	2 5	g
distilled water to	1000	ml

For Leonard jars 200 ml of this solution is added to the sand before sowing For growth pouches 200 ml solution is added directly to 750 ml medium

#### 9 2 3 Jensen's medium

##### 1 Prepare stock solution

H <sub>3</sub> BO <sub>3</sub>	0 31	g
Na <sub>2</sub> MoO <sub>4</sub>	0 01	g
CuSO <sub>4</sub> 5H <sub>2</sub> O	0 01	g
KCl	0 041	g
CaCl <sub>2</sub>	0 001	g
distilled water to	250	ml

##### 2 To prepare 1 liter of medium

CaHPO <sub>4</sub>	1 0	g
K <sub>2</sub> HPO <sub>4</sub>	0 2	g
MgSO <sub>4</sub> 7H <sub>2</sub> O	0 2	g
NaCl	0 2	g
FeCl <sub>3</sub>	0 1	g
Stock solution	5	ml
Distilled water to	1000	ml

#### 9 3 Assembly and use of plants in test tubes

9 3 1 Test tubes (2 0 or 2 5 x 15 cm) with sponge bungs and wooden or styrofoam racks in an adequately lighted and temperature-controlled location are needed The nodulation of Siratro is very sensitive to ambient conditions

- 9 3 2 Add 10 g of agar per liter of Norris and Date pH 6.8 medium, or 20 g of agar per liter of acid (pH 4.5) medium. For acid medium, acidify after autoclaving and before dispensing into the tubes (tubes should be autoclaved separately). Neutral media can be dispensed into the tubes before sterilizing.
- 9 3 3 Allow medium to solidify with the tubes in a vertical or inclined position.
- 9 3 4 Transfer sterile pregerminated seeds (see 9.1) to the tubes and allow the plants to grow for 5-7 days. The seedlings are then inoculated with 1 ml of a suspension of the culture to be tested, prepared as described in 12.1. Allow the shoot to grow out of the tube at one side of the sponge bung (see Figure 9.1).
- 9 3 5 Cover the lower half of the tube with brown paper to prevent light from shining directly onto the roots.
- 9 3 6 Place the tubes in a light chamber (this can be daylight supplemented with incandescent and fluorescent lamps) with temperatures between 25 and 30 °C. If the medium dehydrates during the 4-week incubation, add Norris and Date liquid medium diluted 1:4.
- 9 3 7 Two uninoculated controls should always be included, one without nitrogen and the other containing 0.75 g  $\text{KNO}_3$ /l or other N source.
- 9 3 8 Evaluate for the presence of nodules.

#### 9.4 Assembly and use of growth pouches

Growth pouches are polypropylene (or other sterilizable plastic) bags (16 x 18 cm) with paper wick liners that are folded at the top to form a small trough into which the pregerminated seed is put (see Figure 9.2). Plants are susceptible to contamination and as they are not shielded from radiated heat they are best kept in cooled growth rooms. A special support rack of metal and wood is used (Figure 9.2).

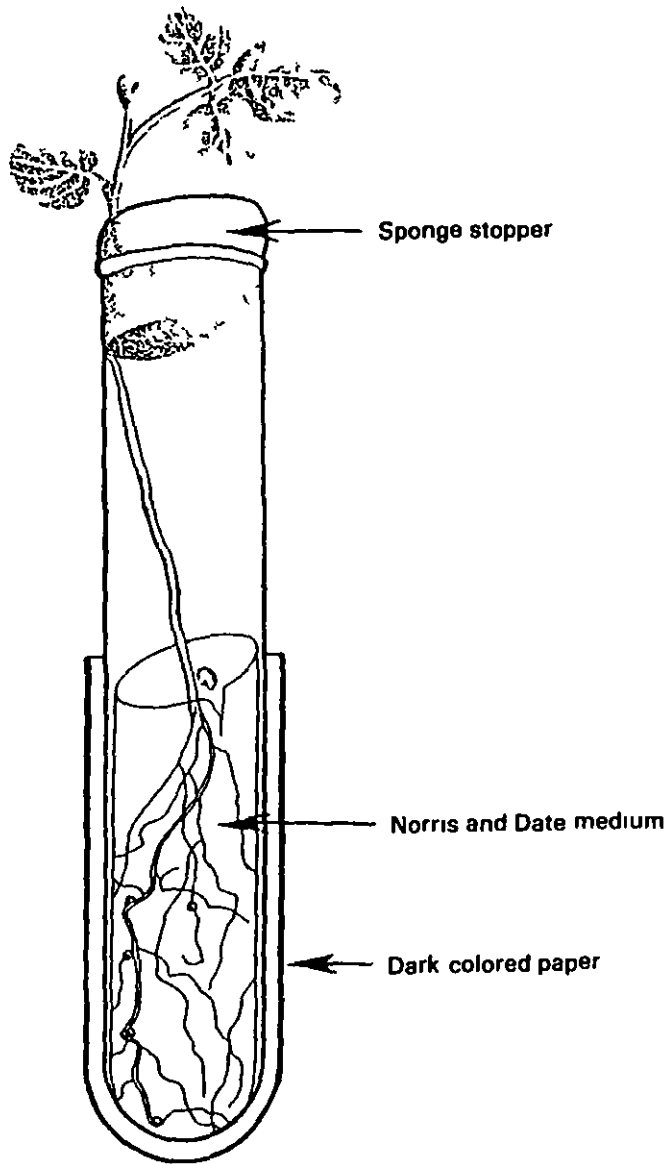
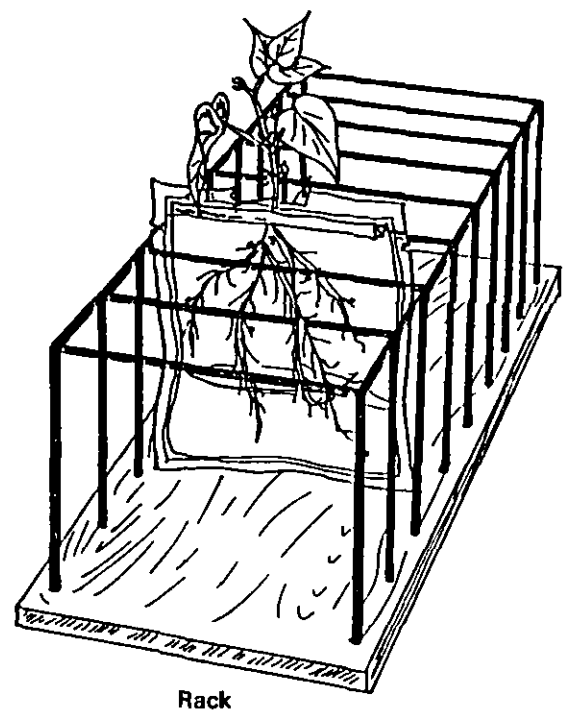
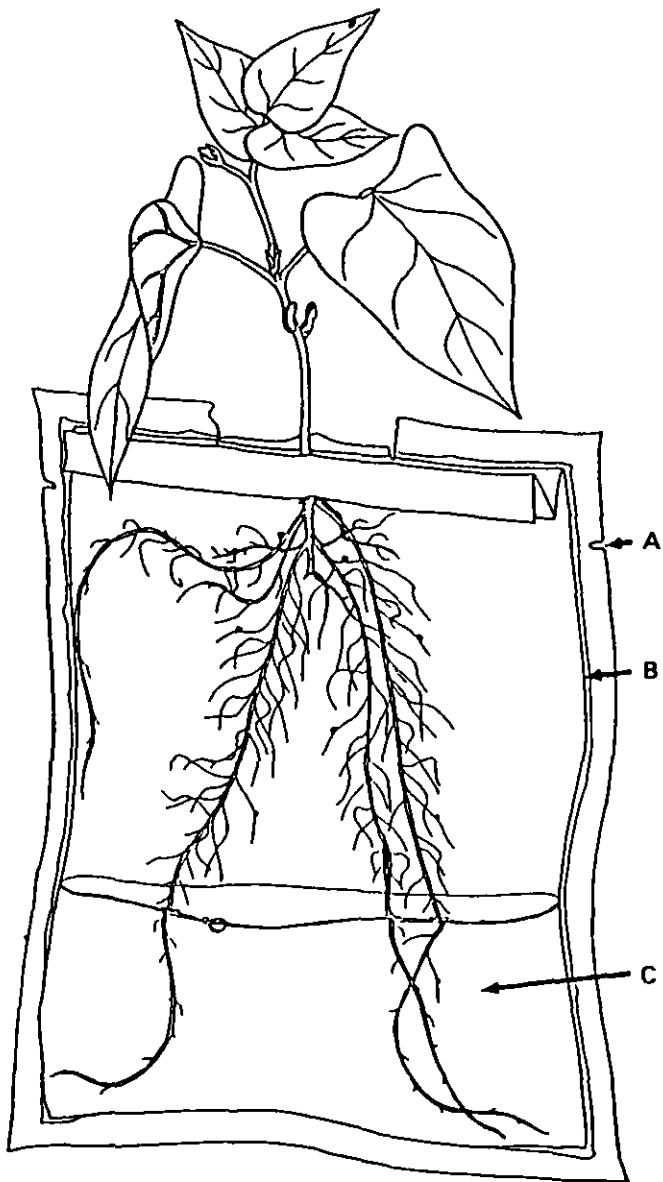

Figure 9 1 Nodulation evaluation of small-seeded legumes in test tubes



A Polypropylene pouch      B Piece of absorbent paper  
C Sandman nutrient solution

Figure 9 2 Growth pouch and rack for the evaluation of nodulation of large-seeded legumes (beans)



9 4 1 Sterile growth pouches with wicks can be purchased, 75 ml of Sandman nutrient solution are added aseptically to these. Alternatively, one can buy sterilizable bags, cut and insert a paper wick, seal the bags (with an electric sealer), and sterilize them, then cut an opening and inject sterile medium into them.

The pouches containing medium can be sterilized in the supports although the metal may cause distortion of the plastic.

9 4 2 Sterilized pregerminated seeds are placed in the trough of the wick. The radicle is inserted into a previously formed hole in the trough (use sterile, fine tweezers).

9 4 3 Incubate in a growth room (20-30 °C) for a week then discard plants with poor growth. Inoculate with 1 ml of rhizobium culture suspension (see 12 1).

9 4 4 Observe plants periodically and replenish nutrient solution if necessary (1:4 dilution). Nodules may be evident after 2 weeks, but plants should be grown at least 3 weeks for a final evaluation.

9 4 5 Uninoculated controls with N (0.57g  $\text{NH}_4\text{NO}_3$ /l) and without N should be included.

#### 9 5 Assembly and use of Leonard jars

The Leonard jar is one of the most used tools in rhizobiology for studying the effectiveness of rhizobium strains under optimum conditions. It was designed by Leonard in 1943. This apparatus permits good microbiological control and it is useful for the authentication of rhizobia or for evaluating the quality of strains. For example, this apparatus is used to make sure that a recommended strain has not lost its capacity to fix nitrogen well. The experience in CIAT is that Leonard jars are not as useful as pots or cores of nonsterile soil for the selection of strains. This is because natural conditions cannot be easily simulated in them.

Competition between inoculated rhizobia and native rhizobia does not occur and this is one of the most important aspects of selecting strains, also it is difficult to maintain acid conditions in the nutrient solution. Thus, in situations where it is not possible to set up all the facilities for rhizobiology work, the use of pots and cores of soil is recommended over Leonard jars.

#### 9 5 1 Apparatus

The upper part of the apparatus consists of a glass bottle (liquor or beer bottle) with a capacity of about 600 ml from which the bottom has been removed. One can remove the bottom of the bottle by heating it with a wire resistor in the appropriate place and then if necessary plunging it into cold water. This bottle is inverted and sits in the lower part, which consists of a wide-mouthed jar of about 1000 ml capacity (see Figure 9 3).

A wick is placed in the neck of the inverted bottle so that nutrient solution (Norris and Date, or Sandman) will be brought up into the upper part of the jar. Good results have been obtained at CIAT using a wick made of cotton wool.

#### 9 5 2 Sand and media

After the wick is placed in the inverted bottle, 400-500 g of washed quartz or river sand is added.

The quality of the sand used affects plant growth. Some sources contain high levels of calcium which inhibit the growth of forage legumes, others may contain high levels of iron. The sand cannot be too fine nor too coarse otherwise anaerobic conditions or insufficient water may result. It is necessary to test several supports in a preliminary experiment. At CIAT ground quartz sand is used.

With 50 kg sand about 100 jars can be set up. Two liters of  $H_2SO_4$  or HCl diluted to 5 liters in water, or 2 liters of muriatic acid are needed.

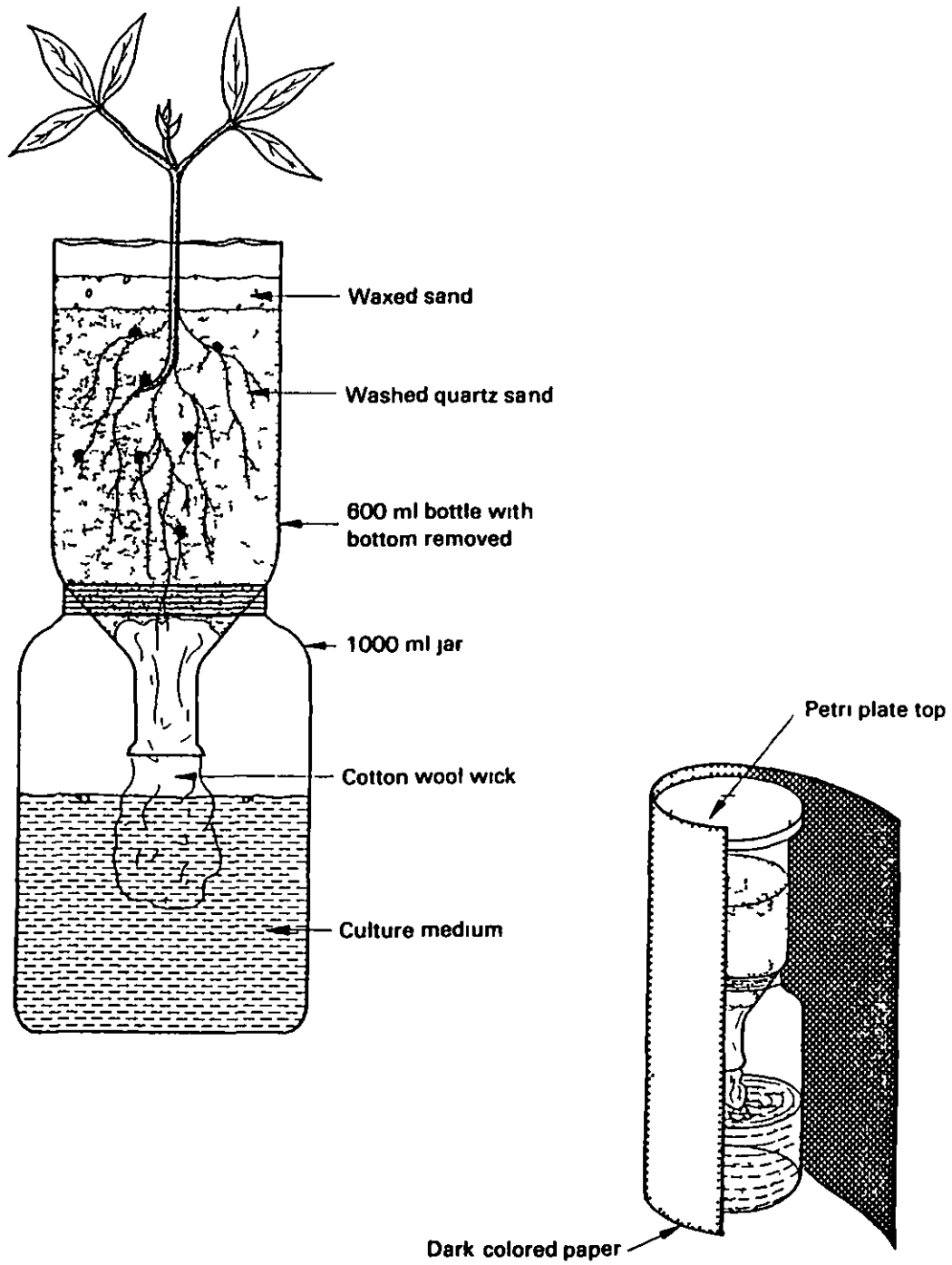

Figure 9 3 Assembly of a Leonard jar

- Put the sand in a plastic container
- Moisten the sand with water
- Add the 5 liters of diluted acid and add water to cover the sand Mix well and let soak for 24 hours
- After 24 hours, insert a hose into the container and fill with water, wash the sand with water until the water runs clear, mixing well throughout the process
- Spread the sand out to dry in the open air

For tropical forage legumes, Norris and Date medium is added to the lower bottle, for beans, Sandman medium is added

### 9 5 3 Sterilization

The top of the bottle is covered with the upper part of a Petri plate or with aluminum foil, the entire jar is wrapped in dark paper which is fastened with adhesive tape or string

Sterilize the entire apparatus in an autoclave for 2 hours Alternatively, to save space in the autoclave and because the bottles with sand sometimes break, the inverted bottle with the sand (sitting on an empty wide-mouthed jar wrapped in paper) can be sterilized with dry heat (160 °C), a second set of wide-mouthed jars containing medium (capped with foil and in a tray wrapped in paper) is sterilized in the autoclave, then the bases are exchanged, taking care to avoid contamination

### 9 5 4 Planting and inoculating

- 1 The jars are set up as described above Write the name or genotype of the legume that is to be planted, the number of the strain and the corresponding replication on the paper covering the jars
- 2 The strains that are to be used as inoculants should be cultured in liquid media for about 2 or 10 days (fast-growing and slow-growing rhizobia, respectively), a cell suspension made from the growth on a Petri plate can also be used as inoculant (see 12 1)

- 3 Two days before planting, sterilize the seeds and place them in Petri plates to germinate (see section 9 1) It may be necessary to scarify the seeds of forage legumes (see Chapter 13) Do this as aseptically as possible to avoid contamination, and plant only seeds that are free of contamination
- 4 On the day of planting moisten the sand in the Leonard jars with Norris medium (for tropical forage legumes) or with 200 ml Sandman calcium solution (for beans) (9 2 2)
- 5 Make holes in the sand with a spatula, and then using sterile forceps, place a germinated seed in each hole For large-seeded legumes plant 2 seeds per jar, and for small-seeded legumes 4 per jar
- 6 Add 0 5 ml of inoculant to each seed and cover the seed with sand Be careful to work with sterile material for each strain, to avoid cross-contamination between strains
- 7 Cover each Leonard jar with a Petri plate top Remove these tops when the plants are about 2 cm high Cover the surface with a layer of sterile waxed sand (13 5)
- 8 Place the jars in a growth chamber or greenhouse
- 9 One week after planting, thin the seedlings keeping only the best ones (1 or 2, depending on the size of the plants) Inoculation can be performed after thinning rather than at the time of planting In this case inoculate each plant with 0 5 ml of culture suspension, and cover with the layer of waxed sand

From 5-8 weeks are needed for these experiments during which time periodic checks on the level of nutrient solution in each jar should be made Replenishing liquid (Norris or Sandman solution

diluted 1:4 or sterile distilled water) is added to the lower jar. At the end of the experiment, plant shoots are harvested and placed in paper bags marked clearly with the strain's number, the name of the legume and the replication. The shoots are analyzed for dry weight.

The roots should be carefully separated from the cotton wicks and placed in labelled plastic bags. Nodules are counted and dry weights of the nodules and roots determined as required in the particular experiment.

The recommended experimental design is a completely random or random block design with 5 replications. Two controls should be included: one control without inoculant and without nitrogen, and one control with nitrogen. For fertilizing with N, use 0.75 g of  $\text{KNO}_3$  in one liter of Norris nutrient solution, or 0.57 g of  $\text{NH}_4\text{NO}_3$  per liter of Sandman nutrient solution, although the required sources and quantities may vary among legumes. Also, small quantities of "starter" nitrogen in the inoculated treatments may stimulate growth and nodulation.

# 10 RHIZOBIUM COUNTS USING THE MOST PROBABLE NUMBER METHOD (MPN)

The infection and formation of nodules in the roots of legumes is the only absolute criterion for distinguishing between rhizobia and other soil microorganisms. When rhizobia are to be counted in a sample that contains various types of microorganisms (for example, inoculant prepared with nonsterile peat, or soil) it is necessary to count the rhizobia indirectly by the formation of nodules on sterile legume plants. The legume that is used most frequently for counts of the group of rhizobia that nodulates forage legumes is "Siratro" (an improved cultivar of Macroptilium atropurpureum) due to its ability to nodulate with a wide range of slow-growing rhizobia. For counts of R. leguminosarum biovar phaseoli beans (Phaseolus vulgaris) are used because no small-seeded legume which nodulates with these rhizobia is known. The MPN method used should be tested beforehand, by comparing the counts obtained from dilutions of a pure culture by both methods (MPN and Petri plates).

## 10 1 Procedure

Prepare, for each count, a series of 6 or more 10-fold dilutions then inoculate 4 plants with each of these dilutions (24 tubes with Siratro or 24 growth pouches with beans or other legume, prepared as described in Chapter 9). It is preferable to make 3 replications of each count, that is make a series of dilutions for each of 3 samples of inoculated seed, inoculant, or soil.

For preparing the dilution series follow the instructions in Chapter 11. Inoculate 1 ml aliquots of the suspension of each dilution into 4 tubes with Siratro or 4 pouches with beans. If 3 replicates of each sample are made, 3 replicates x 6 dilutions x 4 tubes or pouches equals 72 tubes or pouches with the legume, and 18 or more (depending on the number of dilutions) tubes with diluent (0.1% peptone, YMA diluted 1:4 with water or saline solution) are needed. If there is not enough glassware for this, one replicate only can be used (24 tubes with Siratro), however, this does not permit an estimate of the variability. After 3-4 weeks of growth, evaluate nodulation (presence or absence of nodules on the roots of each plant). The MPN table (Table 10 1) is used to calculate the number of rhizobia per seed or gram of soil (see the following examples).

Table 10 1 Estimation of rhizobia numbers <sup>a</sup>

Number (m) of rhizobia estimated by the plant infection count ten-fold dilutions \*

Positive tubes		Dilution steps (s)			
n = 4	n = 2	s = 10			
40	20	>7 × 10 <sup>8</sup>			
39					
38	19	6 9			
37		3,4			
36	18	1,8			
35		1,0			
34	17	5,9 × 10 <sup>7</sup>			
33		3,1	s = 8		
32	16	1,7	>7 × 10 <sup>6</sup>		
31		1 0			
30	15	5 8 × 10 <sup>6</sup>	6 9		
29		3 1	3 4		
28	14	1,7	1 8		
27		1 0	1,0		
26	13	5,8 × 10 <sup>5</sup>	5,9 × 10 <sup>5</sup>		
25		3,1	3,1	s = 6	
24	12	1,7	1,7	>7 × 10 <sup>4</sup>	
23		1,0	1,0		
22	11	5,8 × 10 <sup>4</sup>	5 8 × 10 <sup>4</sup>	6,9	
21		3 1	3,1	3,4	
20	10	1,7	1,7	1 8	
19		1 0	1 0	1,0	
18	9	5,8 × 10 <sup>3</sup>	5,8 × 10 <sup>3</sup>	5 9 × 10 <sup>3</sup>	
17		3 1	3 1	3 1	
16	8	1,7	1 7	1 7	s = 4
15		1 0	1 0	1 0	>7 × 10 <sup>2</sup>
14	7	5 8 × 10 <sup>2</sup>	5,8 × 10 <sup>2</sup>	5 8 × 10 <sup>2</sup>	6 9
13		3 1	3,1	3 1	3 4
12	6	1,7	1 7	1,7	1 8
11		1 0	1 0	1 0	1 0
10	5	5,8 × 10 <sup>1</sup>	5,8 × 10 <sup>1</sup>	5,8 × 10 <sup>1</sup>	5 9 × 10 <sup>1</sup>
9		3 1	3 1	3,1	3 1
8	4	1,7	1,7	1 7	1 7
7		1 0	1 0	1 0	1 0
6	3	5,8 × 1	5,8 × 1	5,8 × 1	5,8 × 1
5		3 1	3,1	3,1	3 1
4	2	1,7	1,7	1,7	1,7
3		1 0	1,0	1 0	1,0
2	1	0,6	0,6	0,6	0 6
1		<0,6	<0,6	<0,6	<0,6
0	0				
Approx	amplitude	10 <sup>9</sup>	10 <sup>7</sup>	10 <sup>5</sup>	10 <sup>3</sup>
Factor, 95% of the confidence limits**					
		(X, -)	n = 2	6,6	
			n = 4	3,8	
* Calculated from Table VIII <sub>2</sub> , Fisher and Yates, 1963					
** Cochrane Biometrics, 1950 <sup>2</sup> , C 6, p 105					

<sup>a</sup> Taken from Vincent, L M , 1970



10 2 Example 1

Samples of 100 seeds of Pueraria phaseoloides, inoculated with strain 2422 and pelleted with lime or rock phosphate were taken. The 100 seeds were suspended in 100 ml (initial volume) of diluent and labelled  $10^2$ . After mixing well, 1 ml of this was added to 9 ml of diluent, this dilution was labelled  $10^3$  and was the first dilution used for inoculating the plants (1 ml/plant). Successive dilutions were prepared in this way, up to  $10^9$ . The results (presence or absence of nodulation) were as follows

<u>Strain 2422 with lime</u>					<u>Strain 2422 with rock phosphate</u>				
<u>Dilution</u>	<u>Tubes</u>				<u>Dilution</u>	<u>Tubes</u>			
	1	2	3	4		1	2	3	4
$10^3$	+	+	+	+	$10^3$	+	+	+	+
$10^4$	+	+	+	+	$10^4$	+	+	+	(-)
$10^5$	+	-	-	-	$10^5$	+	+	+	+
$10^6$	-	-	-	-	$10^6$	+	+	+	+
$10^7$	+	-	-	-	$10^7$	+	+	+	+
$10^8$	-	-	-	-	$10^8$	+	+	+	+
$10^9$	-	-	-	-	$10^9$	-	-	-	-

The MPN Table shows the most probable numbers for 10, 8, 6 or 4 dilutions (S). In this example there were 7 dilutions, therefore consider the dilution  $10^4$  as the first working dilution giving a total of 6 (S=6). It is important to always include a dilution in which all the tubes are negative and another in which all the tubes are positive.

In the treatment with rock phosphate, the plant in one of the tubes at the  $10^4$  dilution did not nodulate. The four following dilutions all demonstrated nodulation. In this case the tube at the  $10^4$  dilution is considered positive<sup>1</sup>. Therefore in the case of lime,

1 In low dilutions a lot of contamination by other organisms can occur. Sometimes this inhibits the growth of the plant and/or the nodulation, and in more diluted samples the plants nodulate because there are fewer contaminants. In these cases, negative tubes at low dilutions are considered positive.

there were 6 positive tubes, and in the case of rock phosphate there were 20

Referring to Table 10 1 in the column S=6, these numbers of positive tubes represent most probable numbers of 5 8 and  $1.8 \times 10^4$  cells in the first dilution considered ( $10^4$ ) for the lime and rock phosphate treatments respectively

Using the formula

$$\text{MPN} = \frac{m \times d}{v \times n}$$

where  $m$  = the most probable number (per ml) in the first dilution considered ( $10^4$ ),

$d$  = dilution of the first dilution considered,

$v$  = volume inoculated onto plants (1 ml),

$n$  = number of seeds, volume or weight of soil or inoculant

$$\text{For lime} \quad \frac{5.8 \times 10^4}{1 \times 100} = 580 \text{ rhizobia per seed}$$

$$\text{For rock phosphate} \quad \frac{1.8 \times 10^4 \times 10^4}{1 \times 100} = 1.8 \times 10^6 \text{ rhizobia per seed}$$

### 10 3 Example 2

Counts of R leguminosarum biovar phaseoli in a farm soil in Tambo, Cauca, Colombia

Three soil samples were taken from the field (replicates) and from each one of these subsamples of 10 g were taken. Each subsample was added to 90 ml of diluent, this initial volume of 100 ml was denoted  $10^2$ . One ml of this dilution was added to each of 4 growth pouches and 10 ml was added to the next dilution blank with 90 ml diluent. This dilution was denoted  $10^3$ , and the dilution series

continued to  $10^7$  in this same manner The nodulation results were as follows

Dilution	Rep I	Rep II	Rep III
$10^2$	+ + + + 4	+ + + + 4	+ + (-) + 4
$10^3$	+ + - + 3	+ + + + 4	+ + + + 4
$10^4$	- + + + 3	- + + + 3	+ + + - 3
$10^5$	+ - + - 2	- - + - 1	+ - + - 2
$10^6$	- - - - 0	- + - - 1	+ - - - 1
$10^7$	- - - - 0	- - - - 0	- - - - 0
Total	12	13	14

According to the MPN Table, the most probable numbers of rhizobia per ml in the  $10^2$  dilutions are  $1.7 \times 10^2$ ,  $3.1 \times 10^2$ , and  $5.8 \times 10^2$  for the 3 replicates respectively

Using the formula

$$MPN = \frac{m \times d}{v \times n}$$

$$I \quad \frac{1.7 \times 10^2 \times 10^2}{1 \times 10 \text{ g}} = 1.7 \times 10^3 \text{ cells/g}$$

$$II \quad \frac{3.1 \times 10^2 \times 10^2}{1 \times 10 \text{ g}} = 3.1 \times 10^3 \text{ cells/g}$$

$$III \quad \frac{5.8 \times 10^2 \times 10^2}{1 \times 10 \text{ g}} = 5.8 \times 10^3 \text{ cells/g}$$

The mean and standard deviation were  $3.5 \times 10^3 \pm 1.7 \times 10^3$  R  
phaseoli per gram of soil in this field



# 11 VIABLE CELL COUNTS OF RHIZOBIA USING PETRI PLATES

The objective of these counts is to ensure that the number of viable cells of rhizobia in inoculants and on inoculated seeds for field trials, is adequate to give good root infection. In cases where inoculation treatments in the field fail these data serve to confirm that the failure was not due to an initial low number of rhizobia, but rather to the lack of adaptation of the strain to the local conditions or to poor compatibility between the legume and strain used.

Counts should be done on the inoculated seeds just before planting them. It is advisable to obtain inoculants for experiments ahead of time so that counts can be done and inoculants of poor quality eliminated before using them in the field. The Petri plate counting method can only be used in cases where the inoculants are in a sterile carrier (samples that are practically contaminant-free). If the sample contains contaminants the most probable number plant infection method should be used (see Chapter 10).

## 11.1 Recommendations for making dilutions

11.1.1 Be sure the cells are separated and well mixed by using glass beads in the dilution bottles or tubes, by adding a detergent to the solutions, and by shaking each sample very well before making the next dilution, if possible using a vortex mixer.

11.1.2 Avoid death or multiplication of cells in the diluent by making the dilution series and plating the samples from one repetition as quickly as possible.

11.1.3 Maintain aseptic conditions using sterile materials, burners, alcohol, and if possible a laminar-flow isolation hood or a hood made according to the NIFTAL instructions (see Appendix A). The use of a UV lamp during the night can greatly reduce contamination in the laboratory.

11 1 4 For dilutions use peptone solution (0.1%) Add Tween 40 (0.1 ml/l) or 1% Calgon (sodium hexametaphosphate) as dispersants The volumes of diluent used should be exact (100, 99, 9, or 0.9 ml), thus it is preferable to dispense the solutions into the tubes or bottles after autoclaving (use a sterile dispensing syringe) For seed counts use 100 or 10 ml in the first dilution bottle, for counts of inoculants, soil, etc, use 99 or 9 ml in the first dilution bottle

11 1 5 To facilitate the work, especially if one is using a NiftAL- type isolation hood, it is preferable to use automatic pipettes with sterile tips (commercial names such as "Gilson" and "Eppendorf") Pipettes of 1.0 and 0.1 ml capacity are used for doing the counts Plastic, sterilizable, "Eppendorf" microcentrifuge tubes (with 0.9 ml diluent) can be used in place of glass screw-capped tubes (with 9 ml diluent), if they can be obtained An electric vortex tube mixer must be used when using Eppendorf tubes (see 11 2 5)

11 1 6 To spread the Petri plates it is convenient to have 5 to 10 glass spread bars that are sterilized by soaking in alcohol and flaming, then allowed to cool several minutes before using

## 11 2 Procedures for counts of pelleted seed samples and inoculants

11 2 1 Before beginning, decide which dilutions are to be plated, this depends on the type of sample For inoculants  $10^4$  to  $10^8$  dilutions are generally plated, while for seed samples  $10^2$  to  $10^6$  dilutions are plated All dilution blanks and Petri plates should be marked with the date, treatment and replication number, and arranged in the order in which they are to be used

11 2 2 From pelleted seed take three samples of 10 seeds each (one sample from each replicate if the seed for each plot has been separated), avoiding contamination between treatments For inoculants, three samples of 1 g each are taken Each sample of seeds or inoculant is placed in a bottle containing 100 ml or

99 ml diluent respectively Shake for about 10 minutes to completely disperse the pellets from the seeds and to separate the cells This dilution is labeled  $10^2$  If 10 or 9 ml are used for the first dilution they are labeled  $10^1$

It is important, especially if there are many treatments, to divide the work by replications and not by treatments If a long time (3-5 hours) is needed to complete the experiment, the number of rhizobia in the dilutions may change, thus it is necessary to complete the entire first replication then proceed to the second, etc

### 11 2 3 Example of a series of dilutions using 1 ml glass pipettes

- 1 From each  $10^2$  dilution take 1 ml with a pipette (no 1) and add this to a tube containing 9 ml of diluent, giving a  $10^3$  dilution From the  $10^2$  dilution and with the same pipette take 0.1 ml and place it in a Petri plate containing YMA medium Spread the sample over the agar surface using a sterile glass spread bar Discard the pipette no 1
- 2 Using a vortex mixer if possible, mix the  $10^3$  dilution and using a clean pipette (no 2) transfer 1 ml to another tube containing 9 ml of diluent, giving a  $10^4$  dilution From the  $10^3$  dilution and with the same pipette no 2 take 0.1 ml and place it in a Petri plate containing YMA medium Spread the sample over the agar surface Discard the pipette no 2
- 3 Continue this sequence to a dilution of  $10^6$  One ml of the previous dilution should always be taken with a new pipette and transferred to a tube with 9 ml of diluent and this same pipette is then used to transfer the 0.1 ml sample to the Petri plate (see Figure 11 1 and Table 11 1)

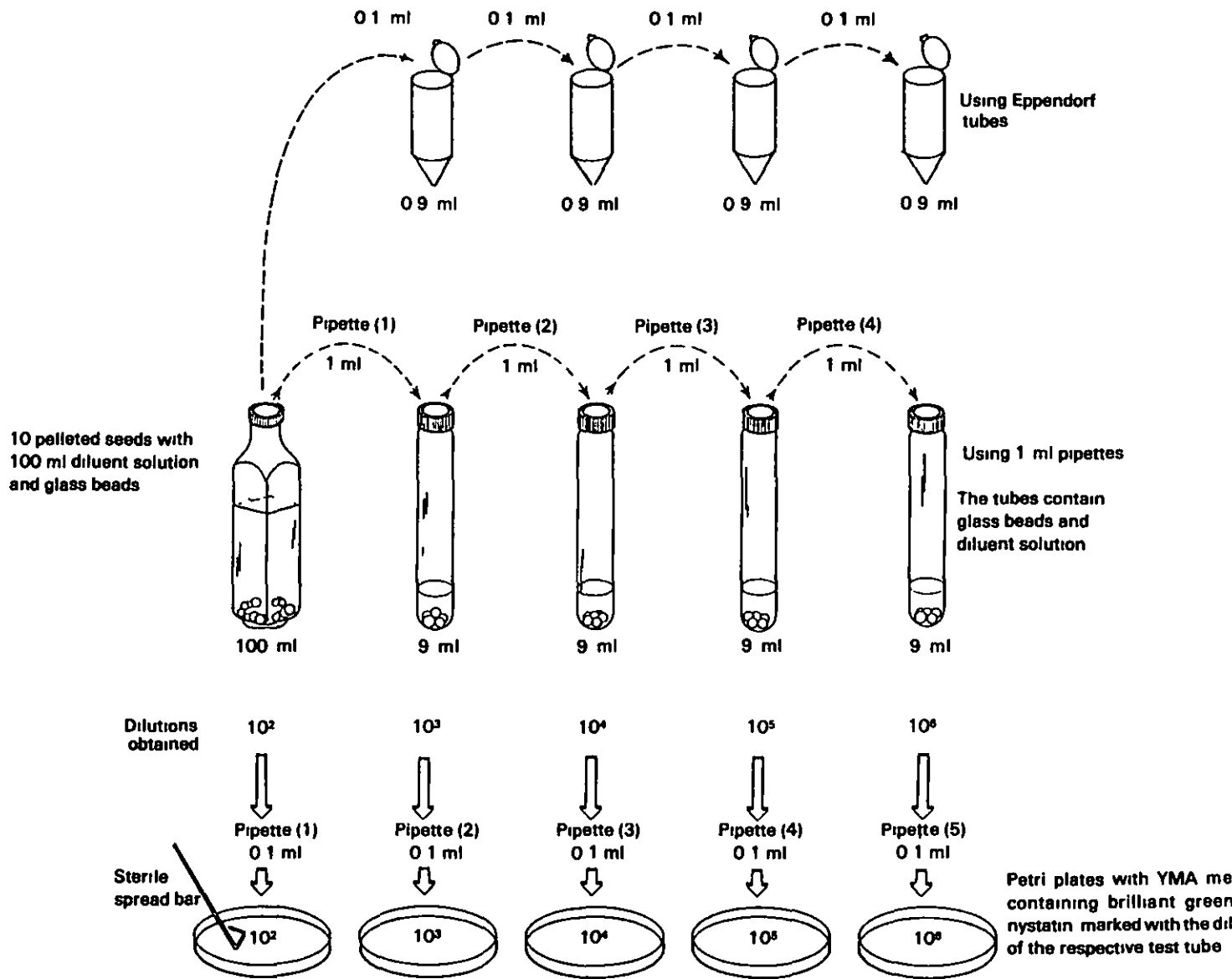

Figure N 1 Dilution and plating scheme for viable cell counts of rhizobia in Petri plates



Table 11 1 Example of dilution scheme for rhizobium counts in an inoculant, plating dilutions  $10^4$  to  $10^8$ , using graduated 1 ml pipettes

Operation	Volume of diluent (ml)	Dilution obtained
Place 1 g of inoculant in the bottle and mix for 10 minutes	99	$10^2$
Use pipette (1) to take 1 ml from bottle ( $10^2$ ), pass to tube ( $10^3$ ) Mix tube $10^3$ well	9	$10^3$
Use pipette (2) and take 1 ml from tube ( $10^3$ ), and pass to tube ( $10^4$ ) Mix tube ( $10^4$ ) well	9	$10^4$
Use pipette (3) and take 1 ml from tube ( $10^4$ ), pass to tube ( $10^5$ ) Place 0.1 ml of $10^4$ on a plate Mix tube ( $10^5$ ) well	9	$10^5$
Use pipette (4) and take 1 ml from tube ( $10^5$ ), pass to tube ( $10^6$ ) Place 0.1 ml of $10^5$ on a Petri plate Mix tube ( $10^6$ ) well	9	$10^6$
Use pipette (5) and take 1 ml from tube ( $10^6$ ), pass to tube ( $10^7$ ) Place 0.1 ml of $10^6$ on a Petri plate Mix tube ( $10^7$ ) well	9	$10^7$
Use pipette (6) and take 1 ml from tube ( $10^7$ ), pass to tube ( $10^8$ ) Place 0.1 ml of $10^7$ on a Petri plate Mix tube ( $10^8$ ) well	9	$10^8$
Use pipette (7) and place 0.1 ml of $10^8$ on a Petri plate		

- 11 2 4 An alternative method is to make the dilution series in the same manner, but without placing a 0.1 ml sample on each Petri plate. When the entire series is completed, one pipette (5) may be used to place the 0.1 ml samples onto all the Petri plates. The samples must be placed following a sequence from the highest (less concentrated) to the lowest (more concentrated) dilution.
- 11 2 5 When automatic pipettes and a 9 ml volume of diluent are used, the 1 ml capacity pipette (with blue tips) is used for the dilutions, and is then changed for the 0.1 ml capacity pipette (yellow tips) to plate out the 0.1 ml aliquots in the Petri plates. If "Eppendorf" tubes with 0.9 ml diluent are used, the whole procedure can be carried out with the 0.1 ml capacity pipette. However, it is essential to mix dilutions made in this small volume using a 'Vortex' mixer.
- 11 2 6 To easily recognize the colonies of the rhizobium strains in the counts, a pure culture of each one should be plated. A loopful of growth is diluted ( $10^5 - 10^8$ ) and spread plated (see 3.8).
- 11 2 7 Plates are inverted and incubated at 26-28 °C for 6-10 days for slow-growing strains and 2-5 days for fast-growing strains. To distinguish between the rhizobia and any possible contaminants, compare the colonies to be counted with the pure culture controls. There may be variability between colonies of a single strain, but by comparing with the pure cultures, this variability can be accounted for. Colonies are marked on the bottom of the plate with a felt-tip pen as they appear. It is necessary to count various times during the incubation period, faster growing colonies may coalesce over time, which makes it difficult to distinguish between them, while other colonies take longer to appear.

### 11 3 Calculations

From each dilution series, choose the Petri plates containing between 30 and 300 colonies. The number of colonies is multiplied by the dilution, and then again by 10, (because only 0.1 ml of the dilution was spread onto each Petri plate). This corresponds to the number of cells on the seed sample or in 1 g of inoculant. To determine the number of rhizobia per seed, divide this result by the number of seed in the sample. Repeat the calculation for each replicate, then determine the mean and the variance.

#### 11 3 1 Example 1 Seeds

Number of colonies on the plate from the  $10^4$  dilution = 36

Number of cells on 10 seeds =  $36 \times 10^5$

Number of cells per seed =  $\frac{36 \times 10^5}{10 \text{ seeds}} = 36 \times 10^4$  (in one replicate)

#### 11 3 2 Example 2 Inoculant

Replicate 1

Number of colonies on the plate from the  $10^6$  dilution = 85

Cells in 1 g =  $\frac{85 \times 10^6 \times 10}{1 \text{ g}} = 8.5 \times 10^8$

Replicate 2

Number of colonies on the plate from the  $10^6$  dilution = 59

Cells in 1 g =  $\frac{59 \times 10^6 \times 10}{1 \text{ g}} = 5.9 \times 10^8$

Replicate 3

Number of colonies on the plate from the  $10^5$  dilution = 291

Cells in 1 g =  $\frac{291 \times 10^5 \times 10}{1 \text{ g}} = 2.9 \times 10^8$

Mean number of rhizobia per g of inoculant =  $5.8 \times 10^8 \pm 2.3 \times 10^8$



# 12

## PREPARATION OF SMALL QUANTITIES OF INOCULANTS FROM PURE RHIZOBIUM CULTURES ON YMA

### 12 1 Broth preparation

12 1 1 Larger quantities of inoculants can be prepared using rhizobia grown in YM broth. The cultures must pass the purity checks as described in Chapter 6. For more information on the production of large quantities of inoculant, refer to FONAIAP, 1982 and Somasegaran and Hoben, 1985.

### 12 1 2 Preparation of small quantities of broth

1 Take several colonies<sup>1</sup> of the rhizobium strain, using a platinum loop, and streak on 3 Petri plates containing YMA. Use pH 5.5 media if working with tropical forage legumes, otherwise use medium with a pH of 6.8.

2 Incubate the plates at 28 °C until there is extensive growth (3-4 days for fast-growing rhizobia, 10-15 days for Bradyrhizobium).

3 To prepare the inoculant choose the two plates with the most growth. Before removing the rhizobia from the Petri plates, examine the colonies, and if there is doubt regarding their purity they should be examined under the microscope to check for contamination (see Chapter 6).

4 Prepare YM broth, dispense 20 ml into 50 ml Erlenmeyer flasks (one flask for each inoculant) and then sterilize.

5 Add a few ml of broth to each of the Petri plates and suspend the rhizobia using a loop.

---

1 Rhizobia are relatively unstable bacteria and quite often lose their N<sub>2</sub> fixation capacity. When making inoculants several colonies are always picked to decrease the probability of producing an inoculant from an individual ineffective mutant. However, when cultures are being purified, they should always be subcultured from individual colonies (Chapters 3, 5 and 6).

6 Use a Pasteur pipette to transfer the cell suspension from the plates into the Erlenmeyer flasks. Close the flasks carefully to avoid contamination.

7 Put the flasks on a shaker to mix well. The broth is then mixed with the peat (on the same day).

## 12.2 Preparation of inoculant in sterile peat

12.2.1 Packets of peat, sterilized by gamma irradiation, can be purchased from Agricultural Laboratories PTY Ltd<sup>1</sup>

Some peats can be sterilized by autoclaving in high density polyethylene bags. These bags (5/100 thickness) can be purchased from Socoplast<sup>2</sup>. These bags are available in some countries for use in microwave ovens. Before autoclaving, the bags are sealed with an electric sealer, and a small hole is made to allow the steam to enter during sterilization.

For sterilization, bags of peat are autoclaved for 1 hour on 3 consecutive days. This ensures that spore-forming fungi and bacteria are eliminated. For small volumes of inoculant that are to be used immediately, the peat can be sterilized in flasks or tubes, capped with cotton wool.

Every peat must be tested for the effect of sterilization on the survival of rhizobia over a 6-month period, and on the liquid retention capacity. Sterilization in an autoclave may release toxic compounds and decrease the peats' ability to retain liquid.

---

1 Agricultural Laboratories PTY Ltd, 95-99 Carlingford Rd, Sefton N S W, Australia. CIAT supplies sterilized peat to those carrying out collaborative trials.

2 Socoplast, 280 Rue Richette, 69400 Villefranche Sur-Saône, France

- 12 2 2 To prepare the inoculants broth is injected directly into the bag of sterile peat (22 ml of broth per 50 g of Australian peat) For each peat source preliminary experiments are necessary to determine the optimum volume of broth Label the bag with the strain number, quantity of inoculant and date of preparation
- 12 2 3 Incubate ("mature") the inoculant at temperatures of 25-28 °C for 1 week leaving open the hole made for injecting the broth to allow cell respiration The injection hole should then be sealed with tape The inoculant can then be used, or stored at 4 °C for up to 6 months
- 12 2 4 Before using the inoculants it is necessary to evaluate their quality by counting the number of rhizobia present If the inoculant is in a sterile carrier the plate count method can be used (see Chapter 11)

### 12 3 Preparation of inoculant in nonsterile peat

Although it is preferable to use sterile peat, inoculants made with nonsterile peat may be equally effective Their quality depends on an adequate control of the growth of fungal contaminants through refrigeration In the absence of a source of sterilizable peat or to reduce the cost of inoculant production nonsterile peat may therefore be used The peat should have been previously tested for its ability to maintain a high rhizobium population for 6 months The whole procedure of inoculant production in nonsterile peat should be carried out outside the sterile areas of the laboratory to avoid contamination

- 12 3 1 The peat should be dried, ground, and sieved with a 100 mesh screen The final size of the particles should be from 10 to 50 microns If preparing granular inoculant use a 40 mesh screen

- 12 3 2 Mix the peat with  $\text{CaCO}_3$  to raise the pH to 6.5 if necessary. The peat used by CIAT has a pH of 5.5 and to raise the pH to neutral it is necessary to add 5%  $\text{CaCO}_3$ . When working with a new source of peat it is necessary to evaluate the survival of rhizobia in the peat with various levels of  $\text{CaCO}_3$ .
- 12 3 3 Mix the broth with the peat in a proportion of 1:2. For example, add 10 ml of broth to 20 g of peat. However, as peats vary in their liquid absorption capacity, it is necessary to determine the optimum proportions for each peat source.
- 12 3 4 Spread out the inoculant and incubate in a clean cool place for 12 hours. If only a very small quantity of inoculant is prepared this time may be reduced to avoid excessive drying.
- 12 3 5 Store the inoculant in a thin plastic bag, previously labelled with the number of the strain, quantity of inoculant, and the date of preparation. This type of inoculant can be stored for 6 months at 4 °C.
- 12 3 6 Before inoculant use, rhizobial counts should always be carried out on inoculants to determine their quality. In the case of non-sterile carriers it is necessary to use the MPN plant infection count (see Chapter 10).



# 13

## EVALUATION OF THE LEGUME-RHIZOBIUM SYMBIOSIS IN UNDISTURBED SOIL CORES (Stages 1 and 2)

In Stage 1, evaluations in undisturbed soil cores are made to determine the response to N and nodulation of different legumes in different soils. Two treatments are compared: 1) low mineral nitrogen (-N) and 2) fertilized with nitrogen (+N). In Stage 2 inoculated treatments are included, these treatments are described in Chapter 19.

Disturbance of the soil is known to cause an increase in nitrogen mineralization. The resulting liberation of mineral N may inhibit nodulation (Sylvester-Bradley et al, 1983, Sylvester-Bradley and Mosquera 1985), the objective of using undisturbed soil is to avoid this effect. This system is used in CIAT to evaluate the effectiveness of the symbiosis of forage legumes in different soils, before carrying out the evaluations in the field. It can be adapted for studies with grain legumes, taking precautions to prevent nutrient deficiencies by varying the size of the cores, the number of plants per core and the fertilization levels. This method cannot be used in cases where it is necessary to lime the soil.

### 13.1 Site selection

The site chosen should be savanna, or a pure grass pasture at least 1 year after establishment.

### 13.2 Taking and preparing the cores

To take out the undisturbed soil, tubes, 10 cm in diameter and 25-cm long, are used. It is practical to use 4-inch-diameter PVC tubing which can be bought in 6 m lengths. Different qualities of tube are available, the most appropriate is known as "sanitary" tubing, with a wall thickness of about 5 mm. From a 6 m length, 23 tubes of 25-cm length can be cut, the inner edge of the bottom of each tube is filed down to facilitate penetration (see Figure 13.1).

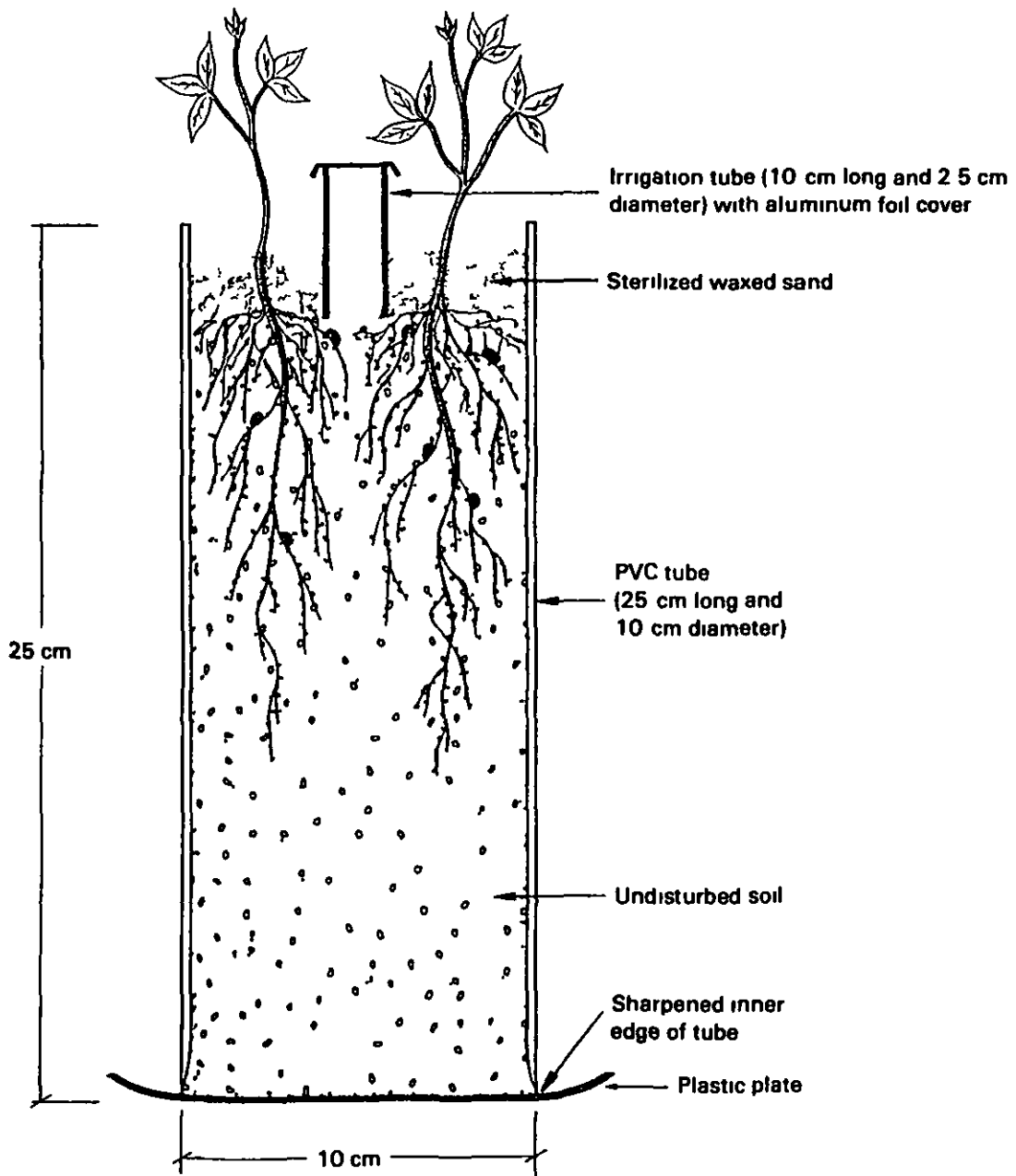

Figure 13 1 Undisturbed soil core

The PVC tubes, protected on top with a wooden plank, are pounded into the soil<sup>1</sup> to about 2 cm from the top edge, leaving enough space for the waxed sand (see below) The cores are removed immediately with a shovel, or they can be left buried until they are needed for an experiment, since they will thus be kept under more natural conditions The soil can be irrigated with clean water if it is extremely hard, however care must be taken to ensure that the entire area to be sampled is watered equally The tubes should be interred in rows, and the areas where they are to be introduced should not be walked on

It is most convenient to transport the cores in wooden crates that hold from 15-20 cores Larger crates are too heavy for easy management

Each core represents a very localized area, therefore the homogeneity achieved in pot experiments, in which the soil is mixed well, is not obtained It may be necessary to use a greater number of replications in core experiments

Before beginning an experiment it is necessary to remove the weeds from the surface, then to weigh the soil cores and determine the moisture content of the soil in a representative sample (see 13 4) The cores are divided into groups each with a given weight range Each group forms a block or replication in the experiment (see 13 4) The cores should be covered with a plate or in another way to prevent contamination before planting

### 13 3 Fertilization

It is important that the nutrient levels added to the soil cores are such that adequate concentrations of the elements are reached in the plant tissue In cores and pots the soil volume is small and root growth is restricted thus it may be necessary to add higher levels of nutrients than would be needed in the field For

---

1 Another method that has worked well is to use a metal tube with a sharpened lower end, into which the PVC tube fits exactly The metal protects the PVC tube when it is being pounded into the soil (R Cantarutti CEPLAC, Brazil)

example in soil cores from Carimagua it is necessary to apply 100-200 kg P/ha to reach the same tissue P levels as 20 kg P/ha added in the field. It is also necessary to add higher levels of K, Ca, Mg and S (CIAT, 1985). With these high fertilization rates, and because the nutrients are applied to the soil surface in the cores, problems of  $\text{Cl}^-$  and  $\text{Na}^+$  toxicity may result. Thus it is recommended that fertilizer doses be split into at least two parts, and sources containing  $\text{Na}^+$  and  $\text{Cl}^-$  be avoided. Preliminary experiments should be conducted on each soil type and core size to determine adequate levels of nutrients, plant tissue is analyzed at the end of the assay. As a guide use the critical levels published in the Tropical Pastures Program Annual Report in the Plant Nutrition Section (CIAT, 1981) and presented in Table 13.1.

Table 13.1 Critical foliar tissue levels of P, Ca, and K for some tropical forage legumes

Legume species	P (%)	Ca (%)	K (%)
<u>C</u> <u>macrocarpum</u>	0.16	0.72	1.24
<u>S</u> <u>capitata</u>	0.18	0.73	1.18
<u>P</u> <u>phaseoloides</u>	0.22	1.04	1.22
<u>D</u> <u>ovalifolium</u>	0.10	0.74	1.03

Table 13.2 shows the fertilizer levels used in CIAT for undisturbed Carimagua soil (acid soil) cores in the evaluation of rhizobia with tropical forage legumes. The tubes used here had an internal diameter of 10.6 cm, giving a surface area of  $88.3 \text{ cm}^2 (\pi r^2)$ . Tubes bought in different lots may vary slightly in diameter. The fertilizer levels should be calculated on the basis of the surface area of each particular lot.

The nutrients are added just before sowing. For the first application of the semi-insoluble fertilizers [ $\text{Ca}(\text{H}_2\text{PO}_4)_2$ ,  $\text{H}_2\text{O}$ ,  $\text{CaCO}_3$ , flowers of sulfur,  $\text{MgO}$ ] the quantity necessary for all the cores is weighed, and mixed with dried ground soil in a measuring cylinder to give a volume of 5 ml/core. This is then applied, with

Table 13 2 Fertilization levels used in undisturbed soil cores from Carimagua  
(surface area of core 88 3 cm<sup>2</sup>)

Nutritional element		Source			Molecular	Element
Symbol	Quantity (kg/ha)	Formula or name	Quantity (kg/ha) (mg/core)		weight	weight in molecule
P	50x2	Ca(H <sub>2</sub> PO <sub>4</sub> ) <sub>2</sub> H <sub>2</sub> O	204x2	180x2	252	62
Ca**	128	32x2 Ca(H <sub>2</sub> PO <sub>4</sub> ) <sub>2</sub> H <sub>2</sub> O	-	-	-	-
		64 CaCO <sub>3</sub>	160	141	100	40
K*	30x2	K <sub>2</sub> SO <sub>4</sub>	67x2	59x2	174	78
S****	60	12 3x2 K <sub>2</sub> SO <sub>4</sub>	-	-		32
		32 5 Flowers of S	38 2	33 7	(85% S)	
		2 95 Zn and Cu	-	-		
Mg	40	MgO	67	59	40	24
Zn	5	ZnSO <sub>4</sub> 7H <sub>2</sub> O	22	19 4	287	65
Cu	1	CuSO <sub>4</sub>	2 51	2 22	160	64
B	0 5	Na <sub>2</sub> B <sub>4</sub> O <sub>7</sub> 10H <sub>2</sub> O	4 3	3 8	382	44
Mo	0 4	Na <sub>2</sub> MoO <sub>4</sub> 2H <sub>2</sub> O	1 01	0 89	242	96
N*****	30x5	Urea	65 2x5	58x5	(46% N)	

\* Add the Ca(H<sub>2</sub>PO<sub>4</sub>)<sub>2</sub> H<sub>2</sub>O and the K<sub>2</sub>SO<sub>4</sub> in 2 parts of 180 and 59 mg/core respectively at 0 and 6 weeks

\*\* Apply 128 kg Ca/ha partially in the Ca(H<sub>2</sub>PO<sub>4</sub>)<sub>2</sub> H<sub>2</sub>O and partially in the CaCO<sub>3</sub>

\*\*\* Add the S with the K (24 64 kg/ha), Zn (2 45), Cu (0 5), and elemental sulfur (32 5 kg S/ha)

\*\*\*\* Add 5 times but only to the treatments with 150 kg N/ha

a 5 ml spoon, to the surface and mixed lightly. The soluble nutrient sources are dissolved in water. The quantity of water added should not be more than the final calculated weight for each core or block (see 13.4). The nitrogen, and the second application of P and K are applied in water through the irrigation tube.

#### 13.4 Water management

To give an adequate, but not excessive, amount of water to the plants, it is necessary to know the required levels of water in the soil and to maintain the soil at this moisture level throughout the experiment. Cores may easily become waterlogged, which is as damaging to plant growth as lack of water. The moisture level should be about equal to field capacity, which can be estimated by sampling the soil one day after a heavy rain storm<sup>1</sup>. The following procedure should be used to achieve the correct moisture level in the cores.

##### 13.4.1 Determining the initial soil moisture percentage

First it is necessary to determine the humidity of the soil in the cores, then to calculate the soil dry weight. Take 3-5 cores and empty out the soil, mix well then take 3 subsamples of 100 g each. These samples are dried in an oven at 120 °C for 24 hr, and then weighed to calculate moisture percentage.

Example

Weight after drying

M <sub>1</sub>	=	75.24 g
M <sub>2</sub>	=	92.20 g
M <sub>3</sub>	=	<u>88.22 g</u>
Total	=	255.66

Mean = 85.22 g

$$\text{Moisture (\%)} = \frac{100 \text{ g} - 85.22 \text{ g}}{100} \times 100 = 14.78\% \text{ (on a wet weight basis)}$$

---

<sup>1</sup> It is important to note that field capacity data, as determined in soil laboratories, is expressed on the basis of percent soil dry weight, whereas here the calculations are made using percent wet weight.

### 13 4 2 Block assignment

All the other cores are weighed on the same day as the soil moisture is determined. Each core is marked with an identification number and its weight. Cores are then divided into groups, each group representing a weight range and a replication in the experiment. Cores not within the weight range of 100 g for each block should be eliminated.

#### Example

Block I 3775-3825 g  
Block II 3826-3875 g  
Block III 3876-3925 g  
Block IV 3926-3975 g  
Block V 3976-4025 g

### 13 4 3 Calculating the final weight of wet soil for each block

The empty PVC tubes used in CIAT weigh 437 g (490 g with the plastic dish). The final weight of wet soil is calculated on the basis of the average weight of the cores of each block.

For example, in Block I

$$3800 \text{ g} - 437 \text{ g} = 3363 \text{ g wet soil weight/core} = \text{WSW}_1$$

where  $\text{WSW}_1$  = initial weight of wet soil

Measured moisture content of the soil = 14.78%

$$\text{Dry soil weight (DSW)} = \text{WSW}_1 - \text{moisture content} = \\ 3363 - \left[ 3363 \times \frac{14.78}{100} \right] = 2866 \text{ g}$$

Assuming that the final desired moisture content for this soil is 20% (on a wet weight basis), to maintain field capacity the dry weight desired is 80% of the final weight of the soil,  $WSW_f$

Dry soil weight (DSW) =  $WSW_f \times 0.8$

$$WSW_f = \frac{DSW}{0.8} = \frac{2866}{0.8} = 3582 \text{ g in Block I}$$

#### 13 4 4 Calculating the final soil weight of the cores (before planting)

The weight of the empty tube (437 g) is added to the final soil weight to obtain the final weight required for the cores in each block

For Block I

$$\begin{aligned} \text{Final core weight with wet soil} &= \text{Final wet soil weight} + \text{core weight} \\ &= 3582 \text{ g} + 437 \text{ g} \\ &= 4019 \text{ g} \\ &= \text{Final core weight (before planting)} \end{aligned}$$

#### 13 4 5 Initial watering of the cores (before planting)

A core in Block I that weighed 3800 g when the humidity was determined would therefore require 219 ml water. If it has since dried out it may require more. All the cores in one block should be taken to the same weight. However, when the range of weights within a block is very wide, it is preferable to calculate the final weight for each individual core than to use the mean weight for each block. It is not necessary to add all the water at this time, only the soil surface needs to be wet. Therefore, initially less water than that needed for the final weight is added to allow space for the nutrient solution and the frequent watering of the germinating seedlings.



### 13 4 6 Calculating the final weight and watering of the planted cores

When the cores are planted, add the weight of the dish (53 g), the soil used for fertilization (5 g), the irrigation tube (25 g), and the waxed sand (65 g), that is, 148 g, to the calculated final core weight of each block. Each week weigh all the cores and correct to the final calculated weight (4019 + 148 = 4167 g for Block I)

### 13 5 Pregermination, planting, and thinning

With tropical forage legumes, experiments are done with two plants per core and five replications per treatment. It is not necessary to sterilize the seeds for these experiments. However seeds of tropical forage legumes should be pregerminated because their germination is variable even when they have been scarified. To scarify use commercial grade sulphuric acid at 45% the time required will depend on the age and condition of the seeds. As a guide, Centrosema spp need about 17 minutes, Stylosanthes capitata about 7 minutes (12 min if the seeds have husks), S guianensis 4-5 minutes and Pueraria phaseoloides 2 minutes. The seeds may also be scarified mechanically (see 9 1 5). The seeds are placed on wet filter paper in Petri plates, and incubated for 1-2 days, until the radicle appears. They should not be left for too long as the radicle may be damaged during planting.

Four small holes are made in the soil surface leaving a space in the center of the core for the irrigation tube. A pregerminated seed is placed in each hole. The cores are watered twice a day during the first week of growth. Details for inoculated treatments are given in 19 1.

When the plants are about 2 cm tall, place the irrigation tube in the center and add a layer of waxed sand. About one week later, thin to two plants in each core.

### Waxed sand

The waxed sand helps maintain a low soil temperature, prevents the soil from drying out and prevents the growth of algae on the soil surface. When the experiment includes inoculants the sand aids in preventing contamination between treatments.

#### Preparation

Method 1 Dissolve 4 g of paraffin wax in 100 ml of benzol. Mix vigorously with 1 kg washed dry quartz sand (9.5:2). When the benzol has evaporated, sterilize the sand (in capped flasks) in an oven at 160 °C for 2 hr. Caution! Benzol is a carcinogen, so use with care.

Method 2 Melt 4 g of paraffin wax and quickly add to 1 kg of hot sand (about 90 °C). Mix well and sterilize for 2 hr at 160 °C.

### 13.6 Nitrogen fertilizer

Nitrogen is added in split doses, through the irrigation tube, beginning 2 weeks after germination. If 150 kg/ha is to be added during a 3 month experiment, the equivalent of 30 kg N/ha should be applied every 2 weeks during the first 10 weeks of the experiment. In some cases higher rates may be needed. Care should be taken that the amount of liquid added is not so large that the soil becomes waterlogged, and treatments that do not receive N should be equalized by adding water.

### 13.7 Harvest and analysis

At the end of the experiment (8-12 weeks depending on the legume) dry weight and N content of the shoot is determined and nodulation evaluated (determine number or dry weight and if required score nodulation for size, color and distribution. See Chapter 17). It is not necessary to evaluate nodulation in the +N treatments.

To facilitate the removal of soil and roots from the cores it is best not to water for one or two days before harvest. The outside of the core is then beaten with a piece of wood, the soil is loosened and slides out easily.

In Stage 1 experiments the results can be evaluated as the difference in N yield of the two treatments expressed as a percentage of the potential N yield (N yield in the +N treatment). The equation for the nitrogen response index (NRI) is as follows:

$$\text{NRI} = \frac{\text{N yield (+N)} - \text{N yield (-N)}}{\text{N yield (+N)}} \times 100$$

Where +N and -N represent N-fertilized and low N treatments respectively. Also the N yields of the legumes in the two treatments are analyzed separately and the rankings compared. For analysis of results of Stage 2 experiments see 19 1 4.



# 14 EVALUATION OF THE LEGUME-RHIZOBIUM SYMBIOSIS IN POTS OF SOIL

(Stages 1 and 2)

Legume-rhizobium combinations can be evaluated in the greenhouse using either undisturbed soil cores (Chapter 13) or pots of soil. This second method is an alternative for work with grain legumes (for example beans) that frequently require the incorporation of lime in the soil.

In experiments corresponding to Stage 1, nodulation and responses to N fertilization of different legume genotypes in different soils are evaluated. Two treatments are therefore applied: one with low availability of mineral nitrogen (-N), and the other in which nitrogen fertilizer is applied (+N). For Stage 2 experiments, inoculated treatments are included (see Chapter 19).

For these evaluations in pots of soil it is important to keep in mind the increase in mineralization that occurs when soil is dried and ground. Although using pots instead of cores has the advantage of a more homogeneous growth environment, it is usually necessary to take special precautions to lower the available N levels in the soil.

## 14.1 Soil preparation

The choice of soil for these experiments should take into account factors such as cropping history (which can affect the native rhizobium population) and the soil pH of the region under study. Soil, to a depth of about 20 cm, should be collected, the debris is removed, the soil dried, ground (if it contains large sods) and then sifted using a 1 cm mesh screen, if considered necessary. If the soil is too fine it may become compacted in the pots.

Take a sample for chemical analysis and also determine the soil pH (suspend a soil sample in an equal amount of distilled water, wait 60 minutes before reading) and add lime if necessary. If lime is added, an incubation period of at least two weeks is required. See the instructions in 14.8 for estimating the amount of lime needed.

The soil and fertilizer are weighed out for each pot to decrease the variability. The insoluble fertilizers are generally mixed with the soil (in a plastic bag or bucket) before filling the pot.

#### 14 2 Minimizing mineral N levels

As the soil preparation methods are likely to result in high mineral N levels in the soil, special measures must be taken in order to have a valid low N treatment. Several options for minimizing mineral N are available.

- 1 Plant a nonleguminous plant in the pots before or together with the legume being tested.
- 2 Mix sugar cassava flour, or some other organic material with a high C/N ratio with the soil. In CIAT 0 4% cassava flour works well, however appropriate proportions have to be determined for a given soil. Keep in mind that these materials may cause problems with the development of pathogenic fungi.
- 3 Add excess amounts of water to leach out the mineral N. If the soil contains a lot of clay it may be necessary to mix it with sand to facilitate water flow. Allow the soil to dry out before proceeding.

#### 14 3 Fertilization

Because of the restricted soil volume in pots and also because the methods used to lower soil N may lower the availability of other nutrients, it is generally necessary to use higher fertilizer rates in pots than are recommended in the field. Doses 3 to 4 times the field levels commonly give similar tissue concentrations. As mentioned in Chapter 13, it is best to avoid sources containing  $\text{Na}^+$  and  $\text{Cl}^-$ . An example of fertilizer levels used in pots of soil from CIAT-Palmira (a neutral fertile soil) are shown in Table 14 1. In place of the individual sources of S, Mg, and K, "sulpomag", a potassium and magnesium sulfate, can be added (2 22 g/pot).

Table 14 1 Fertilizer levels used in 2 kg pots of soil from  
CIAT-Palmira

Nutritional element <sup>a</sup>	Source of fertilizer	Amount of	
		Element (kg/ha)	Source (mg/pot)
P	Triple super phosphate	400	1990
S	Flowers of sulfur	240	212
Mg	MgO	160	266
B	Borax ( $\text{Na}_2\text{B}_4\text{O}_7 \cdot 10\text{H}_2\text{O}$ )	2	18
Zn	$\text{ZnSO}_4 \cdot 7\text{H}_2\text{O}$	20	88
K	$\text{K}_2\text{SO}_4$	120	268

a The nutrients P, S, and Mg are mixed with the dry soil before filling the pots. The nutrients B, Zn, and K are dissolved in water and added just before planting.

#### 14 4 Planting and thinning

With grain legumes (beans), one or two plants are grown in pots filled with 2 kg of soil. Seeds for twice the desired number of plants are sown in moist soil in the pots and after about 1 week (when the first trifoliate leaf just starts to open) the plants are thinned to leave the more vigorous ones. The extra seedlings are carefully pulled out so as not to disturb the roots of the remaining plants or if this is not possible the seedlings are cut to soil level. A completely randomized or random block design with 5 or 6 replications is a useful design for these trials in the greenhouse.

#### 14 5 Nitrogen fertilization

The first application of nitrogen is at the time of thinning and then about every 2 weeks there after Urea or another N source is applied with the irrigation water to give a final combined dose equivalent to 200 to 300 kg N/ha For example, in the CIAT-Palmira soil discussed in 14 3, 130 mg of urea is added per pot every 10 days (5 applications gives the equivalent of 300 kg N/ha)

#### 14 6 Control of moisture

It is very important that the soil humidity be maintained at a constant and adequate level throughout the experiment Extremes in humidity have a strong effect on nodulation and N<sub>2</sub> fixation

There are a number of ways to estimate field capacity of a soil One, as described in Chapter 13, involves watering the soil in the field, allowing it to drain and determining the moisture content the following day A second method is to fill a transparent plastic or glass measuring cylinder (200-300 ml capacity), that has a small hole in the bottom, with the soil Slowly add tap water to the soil until about 2/3 of the soil is wet Allow to equilibrate for 24 hours, then mark off and discard the top 5-cm of soil Take the second 5-cm layer of soil, weigh it, dry it, and reweigh, to determine the percent moisture at which the pots should be maintained

Moisture can be determined directly in pots of soil, but drainage is very poor, and field capacity may be over-estimated Therefore it is recommended that 70% of field capacity determined by this method be maintained during experiments

#### 14 7 Harvest and analysis

To get the most information from this type of experiment grain legumes should be harvested at the mid- to late flowering stage when nodulation and rates of N<sub>2</sub> fixation are usually at maximum



levels and plant N generally indicates final plant N. However, in some cases final total N yield or grain yield are of more critical interest and plants are harvested at late pod fill and maturity respectively. As the nodules have senesced by this time, nodulation cannot be evaluated, also grain yield determinations based on such a small number of plants are extremely variable.

At harvest the shoot is cut at soil level (at the first node). The entire shoot can be dried, weighed, and ground, or the pods can be separated first. Nitrogen concentration is determined and total plant N calculated. The results of Stage 1-type experiments can be expressed in the form of nitrogen response index (NRI) as described in 13.7. For analysis of Stage 2 experiments, that include inoculation, see 19.1.4.

The roots are carefully separated from the soil and washed in a sieve with running water. Nodulation is evaluated in the low N treatments, on the basis of nodule number, mass or volume, and internal color (see Chapter 17). The roots are dried and weighed and percentage of N determined, either separately or in a combined sample with the shoot.

## 14.8 Estimation of the amount of lime needed to raise the pH of a soil<sup>1</sup>

### 14.8.1 Method 1 Incubation with calcium hydroxide

#### 1 Preparation of saturated calcium hydroxide solution

Add 1 g of calcium oxide or 1.5 g of calcium hydroxide to 1 liter of water (degassed under vacuum to eliminate the CO<sub>2</sub>). Wait until the excess precipitates and then decant the supernatant. The concentration of the saturated solution is approximately 0.04 meq Ca/ml. Store the solution protected from the CO<sub>2</sub> in the air as the Ca concentration declines when it is precipitated as carbonate.

---

<sup>1</sup> American Society of Agronomy, 1982

## 2 Method

Put 10 g of soil in each of 7 beakers of 100 ml capacity. Add 0, 5, 15, 20, 30, 40 and 50 ml of saturated calcium hydroxide solution to beakers 1-7 respectively. Add sufficient water to give a 1:5 soil to water solution. Wait 3 days and measure the pH of the 7 suspensions.

Prepare a graph of the pH observed vs the milliequivalents of Ca added per 100 g of soil (1 meq of Ca = 20 mg). The graph is used to determine the quantity of calcium needed to reach the desired pH. From this the amount of  $\text{CaCO}_3$  to be added to each pot, or per ha in the field is calculated.

For example, a soil with a density of  $1.2 \text{ g/cm}^3$  has  $2.4 \times 10^9 \text{ g}$  of soil per ha to a 20-cm depth.

$$(10,000 \text{ m}^2/\text{ha} \times 0.2 \text{ m} = 2000 \text{ m}^3/\text{ha} = 2 \times 10^9 \text{ cm}^3/\text{ha}, \\ 2 \times 10^9 \text{ cm}^3/\text{ha} \times 1.2 \text{ g/cm}^3 = 2.4 \times 10^9 \text{ g/ha})$$

Assuming that in this soil 20 mg of Ca was sufficient to reach the desired pH, the calculation is as follows: 20 mg Ca per 100 g of soil is equivalent to 480 kg Ca per ha ( $20 \text{ mg Ca} \times 2.4 \times 10^9 \text{ g/100 g} = 48 \times 10^7 \text{ mg Ca} = 480 \text{ kg Ca}$ ). Since 100 kg  $\text{CaCO}_3$  contains 40 kg of Ca, 1.2 ton lime per ha are required.

14.8.2 Method 2 Based on the exchange acidity (aluminum and hydrogen) for soils with a pH less than 5.4 (Salinas and García, 1985)

### 1 Extraction

- a Dissolve 74.56 g of KCl in 500 ml of deionized or distilled water, and complete to a volume of 1 liter, to give 1N KCl.
- b Put 10 g of dry soil in a 100 ml Erlenmeyer flask.
- c Add 50 ml 1N KCl.

- d Mix for 30 minutes and filter into a 100 ml volumetric flask
- e Wash the soil with 5 more 10 ml portions of KCl, collecting the filtrate in the same flask and completing to 100 ml final volume with 1N KCl

## 2 Titration

- a Transfer 50 ml of the extract to a 125 ml Erlenmeyer flask and add 3 drops 1% phenolphthalein
- b Titrate with 0.05 N NaOH until a permanent, pale red color develops. Note the volume (ml NaOH) used in the titration

## 3 Calculations

Acidity (meq/100 g soil) =

$$\text{ml NaOH} \times \text{N NaOH} \times \frac{100 \text{ g soil}}{10 \text{ g sample}} \times \frac{100 \text{ ml extract}}{50 \text{ ml aliquot}} =$$

$$= \text{ml NaOH} \times 0.05 \times 20$$

Therefore, acidity (meq/100 g soil) = ml NaOH

Ca requirement (meq/100 g soil) = 1.5 x degree of acidity

This conversion factor will depend to some extent on the crop being studied (Cochrane et al 1980). The lime requirement in kg/ha is calculated from meq Ca/100 g soil as described in the last part of 14.8.1.2



# 15

## EVALUATION OF THE FORAGE LEGUME-RHIZOBIUM SYMBIOSIS IN THE FIELD (Stages 1 and 2)

It has been demonstrated that the establishment of forage legumes using minimum tillage permits a reliable evaluation of the effectiveness of legume-rhizobium combinations (Sylvester-Bradley and Mosquera, 1985). With reduced tillage, rates of mineralization and levels of available mineral N in the soil are lowered due to lack of soil disturbance and competition from the grass that grows in the rows between the legumes (Figure 15.1). As well as minimizing the availability of mineral N, this method assures good legume establishment by preventing soil erosion and seed loss or burial by the rains.

These experiments are only evaluated up to the end of the establishment phase, which means that land is more easily obtained for them, as the owner can initiate grazing as soon as the experiment is over.

In Stage 1 and 2 type experiments, which require information on the genetic potential of the plant to fix nitrogen with native or inoculated rhizobium strains, it is necessary to maintain optimal growth conditions, using adequate fertilizer levels. The effect of stress conditions on the symbiosis is evaluated in Stage 3 (Chapter 20).

### 15.1 Time of planting

It is important to use the same planting season as the farmers in the region.

### 15.2 Site selection

To reduce variability to have sufficient plants for nodulation evaluations and to allow for various cuts in different sites during establishment, large plots are required. The site should be in an area with little slope and representative of the region, and legumes should not have been planted previously. The area may be native savanna, degraded pasture or preestablished grass. It is

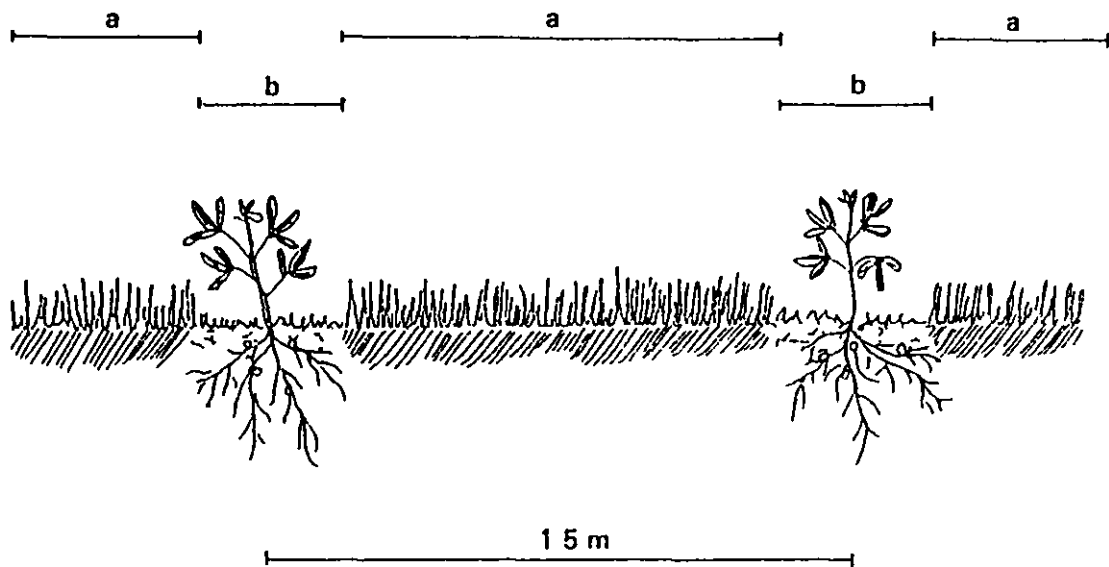

- a Preestablished grass or savanna, burnt or mown shortly before sowing
- b Ten to 40-cm-wide rows, fertilized and planted with the legume

Figure 15 1 Reduced tillage for evaluating tropical forage legumes

important that the grass is established beforehand in order to avoid uneven growth, which will in turn affect legume establishment

### 15 3 Experimental design

The plots consist of furrows made in an undisturbed grass sward with 1.5 m between them. The furrows are 10 to 40 cm wide.

To make two cuts per plot, each one made up of three 2 m long subsamples, at least 12 linear meters are needed per plot. However, in view of the great variability which occurs within small areas during tropical forage legume establishment, at least 18 linear meters are recommended per plot. This allows for the sites of the subsamples to be distributed randomly within the plots. Border effects do not occur, because of the large distance between furrows.

The furrows and the blocks should always be orientated across the slope. If more than 2 cuts are to be made the plot size may be increased to 40 linear meters (see Figure 15.2).

The plan shown in Figure 15.3 demonstrates a Stage 1 type of experiment with a split-plot design. A randomized block design would give greater precision, but greater care would be needed with N applications. The design of Stage 2-type experiments is discussed in Chapter 19.

### 15 4 Land preparation

Burn the savanna or mow the grass to lessen competition between the native plants and those legumes to be planted. Furrows 10-15 cm deep can be made using a hoe, making sure the roots of the grass are eliminated from the area to be planted. A cultivator can also be used to make the furrows, two chisels for each furrow are mounted 40 cm apart on the first bar of the cultivator and a small

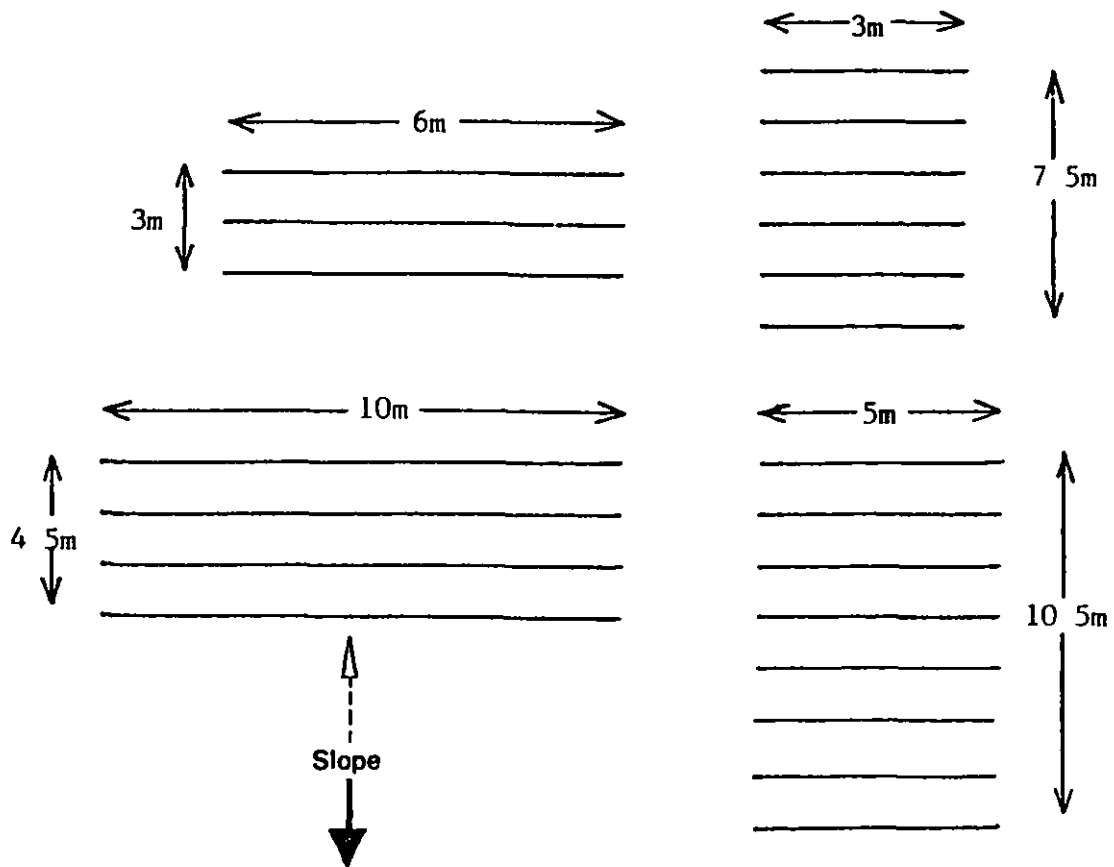

Figure 15 2 Size and orientation of plots in field trials with tropical forage legumes (Example 18 linear meters for 2 cuts, 40 linear meters for 3 or 4 cuts)



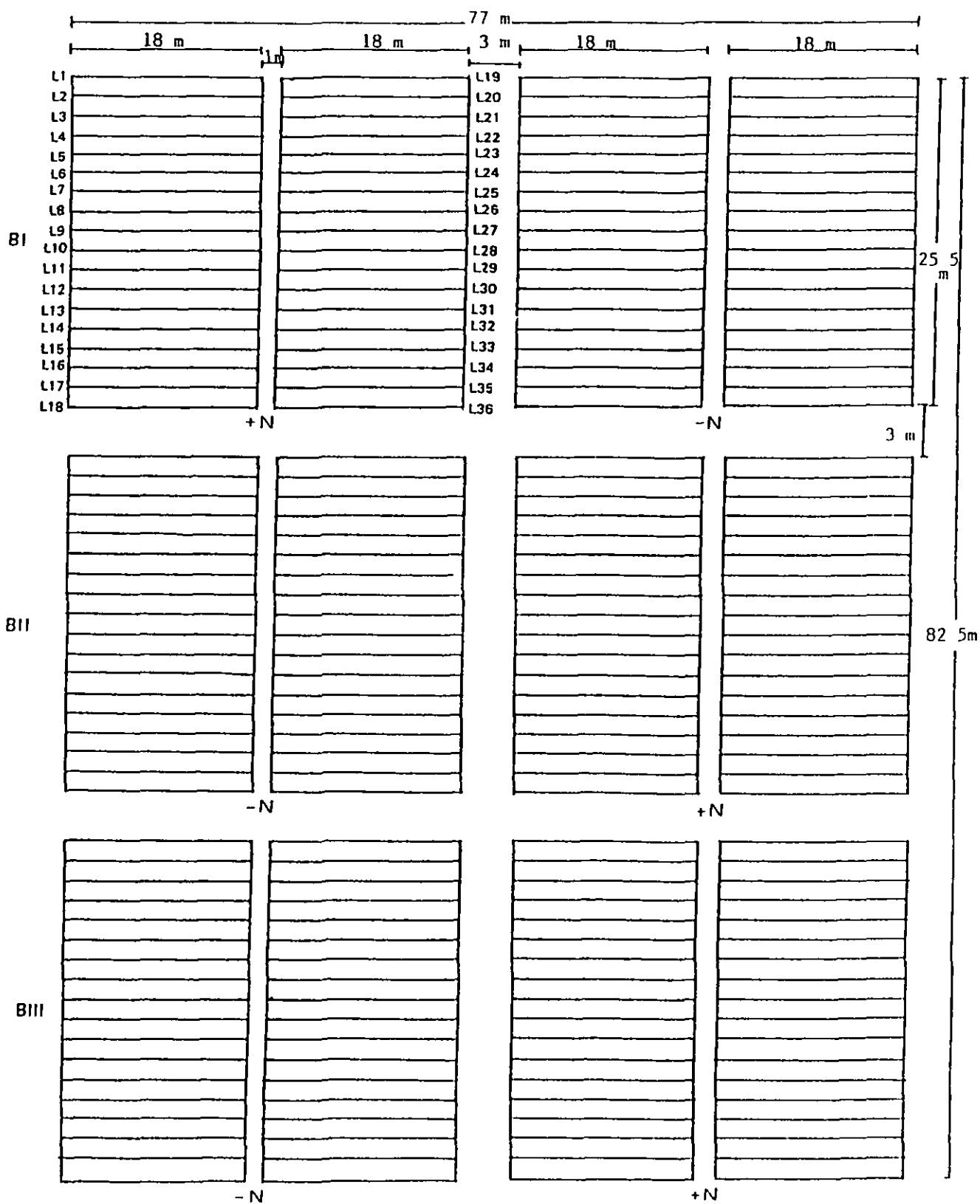

Figure 15 3 Field map of Stage 1-type experiment Main plots N  
fertilizer subplots legumes

shovel-sweep is placed on the second bar at the midpoint between the two chisels. Alternatively the sweep may be on the first bar and the chisels on the second. It may be necessary to adapt the way the furrows are prepared for each site, depending on the available machinery, the characteristics of the soil and the associated grass. Try out the method to be used at each site before-hand. Fence off the land to be used for the experiment before planting to keep animals out. Problems may arise with land preparation, it is therefore advisable to prepare the furrows at least a few days before the planting date.

#### 15.5 Fertilization

Fertilizer is applied in the furrows, calculating the quantity necessary for  $1 \text{ m}^2$  for each linear meter of furrow. In the absence of specific recommendations for the experimental site, it is recommended that the following be applied (g/m of furrow): 12.0 Ca, 2.2 P, 4.0 S, 3.3 K, 2.0 Mg, 0.5 Zn, 0.2 Cu, 0.1 B, and 0.04 Mo. Incorporate the fertilizer using a hoe, and preferably wait until it rains before planting. Direct contact of seeds with fertilizer may cause damage.

For the plus nitrogen treatment (+N), apply 20 kg N/ha every 2 weeks (4.3 g urea/m of furrow), throughout the experiment, making the first application 2-4 weeks after planting. If there is a dry period before the end of the experiment suspend N applications until the rains begin again. High levels of N are necessary, since the objective of this treatment is to demonstrate the yield potential of the plants when nitrogen is not a limiting factor in growth.

#### 15.6 Identification of the plots

Before planting, place painted stakes with the numbers of the treatments and blocks in each plot.

### 15 7 Planting

Plant on a day when the soil is moist, but it is not raining nor is it very sunny. Plant in the center of each furrow, using a seeding rate to give 15-20 plants/linear meter. Seeds should be washed if treated with fungicides and scarified with acid (see 13 5). For Centrosema spp, 1 g seed/m, P. phaseoloides 0.4 g/m, Desmodium spp and Stylosanthes spp 0.3 g/m are generally sufficient. Cover the seeds with a little soil and compact it down with an implement or by walking on it so rain will not wash the seeds away. For experiments that include inoculated treatments Stage 2 see Chapter 19.

### 15 8 Weed control

Hand weed the plots throughout the experiment. Control ants, etc., with Aldrin or other insecticide. If the grass grows excessively it can be cut with a machete.

### 15 9 Replanting and thinning

If possible avoid replanting. If the population is very poorly distributed, seedlings can be transplanted within the same treatments, always transplanting the seedling with the surrounding soil and trying not to disturb the roots. Thinning is easier than replanting and is used to prevent excessive competition between plants where too many seeds have germinated in the same place.

### 15 10 Cuts

The minimum number of cuts during establishment is 2. For each one, cut 3 subsamples of 2 linear meters from sites randomly selected within each plot. For each cut, take the subsamples from a different site and cut to soil level. Usually the first cut is made 9-12 weeks after planting, and the last cut (4-5 months after planting) when the legumes have grown enough to be grazed.

Record the number of plants in each subsample and pool the 3 subsamples to determine fresh weight. If the growth season is very short, one cut can be made during the first season, and then proceed with the other cut when the next rainy season begins. However, it is not necessary to continue evaluating once the legumes are established, or ready for grazing, as the conditions are already not those representative of pasture under grazing.

After pooling the 3 subsamples from the field, and weighing to determine fresh weight, take a subsample of 100 g to dry (or take the whole sample if it is less than 100 g). Dry the samples at 60–80 °C, grind them, and determine the percentage of nitrogen. Consider that each linear meter of furrow represents 1 m<sup>2</sup>, thus the three subsamples of 2 linear meters represent 6 m<sup>2</sup>. This sample is sufficiently large in order to cover the variability that exists within the plots.

#### 15 11 Evaluating nodulation

Nodulation is evaluated according to the instructions given in Chapter 17.

#### 15 12 Analysis of data

In Stage 1 experiments with two treatments per legume (-N and +N), the response of each legume to nitrogen is calculated and legumes are compared using the NRI (see 13 7). Also the rankings of the legumes for N yield in the two treatments are evaluated separately. These data are compared to the nodulation data and legume-soil combinations are selected on the basis of these results for future experiments. For analysis of data of Stage 2-type experiments, the IEI is used (see 19 1 4).

# 16 EVALUATION OF THE BEAN-RHIZOBIUM SYMBIOSIS IN THE FIELD

(Stages 1 and 2)

In Stage 1 experiments nodulation and responses of bean genotypes to N fertilizer are evaluated in different soils using treatments with high and low availability of mineral N. The ability of a given bean genotype to reach its potential with nitrogen being supplied from a symbiosis with the native Rhizobium phaseoli population is determined. A dramatic response to nitrogen fertilizer indicates that the native rhizobium population is fairly ineffective and/or the bean genotype has poor nitrogen fixation potential. In Stage 2 experiments, inoculated treatments are included (see Chapter 19).

## 16.1 Site selection and methods to minimize soil mineral nitrogen

A site representative of the region under study should be selected, however in the case of beans in monoculture it may be necessary to take special precautions to ensure low availability of mineral N. If possible an evaluation of mineralization rates should be made (see Chapter 18).

If the initial levels of mineral N are high a cover crop of maize harvested just before planting the beans, will help to reduce them. If mineralization rates are high, incorporation of sawdust, rice or cane straw ( $1 \text{ kg/m}^2$ ), which increase the C/N ratio, will lower the availability of N. The other option is to use some kind of intercrop, for example a row of wheat or maize planted between the bean rows. It is necessary to do preliminary experiments to select the best method for minimizing mineral nitrogen.

## 16.2 Experimental design

A minimum of two treatments per genotype is required and to facilitate management of nitrogen fertilization a split-plot design with N treatments as the main plots, and genotypes as the

subplots is useful. If a randomized block design is used it is important to leave sufficient space between the plots to avoid carry-over of N-fertilizer, and also a fairly flat site is required.

When deciding on plot sizes, remember that 6-8 plants are needed for each nodulation evaluation. A minimum of 3 replications per treatment is recommended. The plan shown in Figure 16.1 demonstrates the design of a Stage 1-type experiment.

### 16.3 Fertilization

For high mineral N treatments, split doses of urea or other nitrogenous fertilizer should be applied to give a total application of 150 to 200 kg N/ha. Band applications every 2 weeks are recommended.

In Stage 1 and 2 experiments, when information on the genetic potential of the bean germplasm with native or inoculated rhizobium strains is required, good growth conditions with irrigation, fertilizer, and pesticides should be used. Lime, P, K, and micronutrients should be applied as required, to the entire experimental area. Weeds should be controlled, as they will affect the availability of mineral N as well as other nutrients.

Expression of good fixation potential under stress conditions (e.g., low P or drought), is evaluated later (Stage 3).

### 16.4 Evaluation of nodulation

Nodulation should be evaluated according to the instructions given in Chapter 17. If only one evaluation is possible it should be done at the mid-flowering stage when number and mass are highest. Early nodulation is important however and should be evaluated if possible.

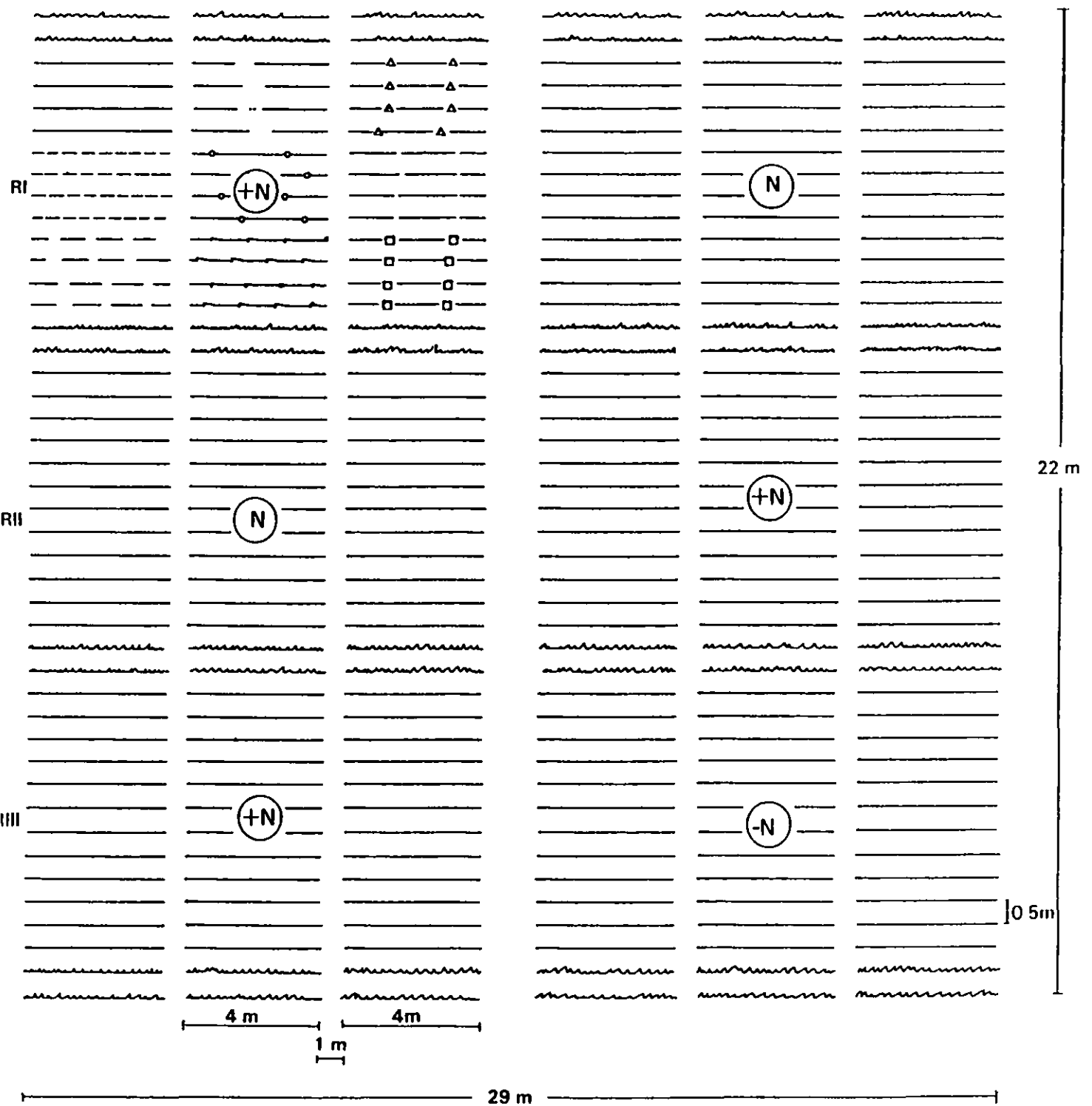

Figure 16 1 Field plan of a Stage 1 bean trial Nine genotypes grown at low and high levels of N, and 3 replicates

## 16 5 Evaluation of yield

Vegetative vigor is often related to nitrogen fixation, thus at the mid-flowering stage the plants that are dug up for evaluation of nodulation can be dried and weighed to give an estimate of vigor

Maximum total plant N is generally reached during late pod fill, before the leaves drop. The plants can be harvested at this time and total N determined. However, it is more common to evaluate grain yield

Genotypes vary in their N harvest index (proportion of total N found in the grain), and in specific breeding projects for increasing yield or fixation potential of beans this information is valuable

In Stage 1-type experiments, however, it is usually sufficient to determine grain yield, and when possible the N concentration in the grain. The latter because it varies between genotypes and for a given genotype will vary depending on environmental conditions

In intercropped systems, the determination of N yield of the associated crop is also required, because the overall N balance is of interest. A bean genotype with an effective nitrogen-fixing symbiosis will compete less for the small amount of soil N available and differences between treatments may be more apparent in the associated crop, than in the bean crop itself

## 16 6 Analysis of data

In Stage 1 experiments with two treatments per genotype (uninoculated with low and high availability of mineral N) the response of each genotype to nitrogen is analyzed (NRI, see 13 7). Also the rankings of the genotypes in the two treatments are evaluated separately. These data are compared to the nodulation data and genotypes are selected for further experiments. Data of Stage 2-type experiments are analyzed using the IEI together with the other evaluation parameters (see 19 1 4)



# 17 METHODS FOR EVALUATING NODULATION

The method chosen for evaluating nodulation will depend on type and range of legume germplasm, the age of the plants, the number of nodules, and the ease with which the roots are removed from the soil. In general, nodulation is not evaluated in treatments fertilized with N

## 17 1 Tropical forage legumes

### 17 1 1 Nodulation evaluations in experiments in undisturbed soil cores

In greenhouse experiments it is relatively easy to recover all the nodules, although it is not possible to separate the roots of two plants in the same core. The nodules of many forage legumes are small, which makes estimating weight difficult. Also the small quantities of soil often attached to the nodules are almost impossible to remove completely, and greatly affect the reliability of the measurements. Thus it is recommended that the nodules only be counted.

Remove the soil from the cores and wash the roots carefully in a sieve with running water. If the nodules cannot be counted immediately the roots and nodules should be stored frozen in labelled plastic bags.

### 17 1 2 Nodulation evaluations during legume establishment in the field

In a field experiment it is necessary to carry out at least two nodulation evaluations during establishment.

#### 1 General considerations concerning the parameters to be evaluated

The number of nodules per plant is the most important parameter. In experiments in which there are treatments with abundant nodulation (more than 50 nodules per plant), abundance can be evaluated using categories as shown in Table 17 1. If

Table 17 1 Ratings for the evaluation of nodulation of individual tropical forage legume plants (four parameters)

A <u>Abundance</u> (Approximate number of nodules per plant)			D <u>Predominant internal color</u> (Approximately 10 living nodules/plant)		
<u>Evaluation</u>		<u>Rating</u>	<u>Evaluation</u>		<u>Rating</u>
More than 100	Very abundant	4	Black		9
50-100	Abundant	3	Red <sup>b</sup>		8
10- 50	Medium	2	Green		7
1- 10	Few	1	White		6
0	None	0	Brown		5
			Red and green <sup>c</sup>		4
			Red and black		3
			Brown and green		2
			No predominant color		1
			No nodules		0
B <u>Predominant size</u>					
<u>Evaluation</u>		<u>Rating</u>			
Large		4			
Medium		3			
Small		2			
No predominant size		1			
No nodules		0			
C <u>Nodulation on the tap root<sup>a</sup></u>					
<u>Evaluation</u>		<u>Rating</u>			
Predominant		3			
Medium		2			
None		1			
No nodules		0			

- a This parameter is relative for each plant "predominant" means that most of the nodules are on the tap root
- b The color red includes pink and other variations of the color red
- c The double colors (ratings 2, 3, and 4) represent nodules that contain two colors within a nodule

there are no plants with abundant nodulation, it is preferable to count the nodules. It is recommended that some of the most vigorous plants in treatments without N fertilizer be examined, to help decide whether counts or categories are to be used to evaluate abundance.

In general the first nodulation evaluation is done 6 weeks after planting, and nodules per plant are counted. For the second evaluation (12-16 weeks) it may be preferable to use categories of abundance if there are treatments with more than 50 nodules per plant.

The categories of "predominant size" nodulation on the main tap root ("distribution"), and "predominant internal color" (Table 17.1) are used to complement the data on abundance. It is not always necessary to evaluate these parameters, although when there are differences between treatments it is advisable to do so.

## 2 Taking the samples

Six plants per plot are evaluated. It is advisable to reserve the plants on the ends of the rows (the last 50 cm of each row) for early nodulation evaluations. If nodule internal color is to be evaluated, it must be done in the field because the colors deteriorate rapidly once the roots are removed from the soil. First the nodules are counted, because they are destroyed when internal color is determined.

To take samples, dig carefully around the plant, without destroying the root system, and include the nodules on secondary roots often at some distance from the main tap root.

### 3 Methods for evaluating nodulation

For evaluating nodulation take a reference card, such as the one shown in Figure 17 1, to the field, then record the data on a form such as the one on page 17-7

#### a Abundance

Record either the exact or approximate number of nodules  
If evaluating the approximate number, record the rating for each plant (0, 1, 2, 3 or 4)

#### b Size

The nodule size categories depend on the plant genus  
Centrosema spp and Pueraria phaseoloides form larger nodules than Stylosanthes, Desmodium, Zornia and Arachis Figure 17 2 can be used as a guide for evaluating nodule size of the groups of legumes mentioned However, this guide can be adapted if the evaluator considers it necessary as long as the categories are defined and fixed for each experiment It is important that the roots be examined very carefully as there may be a mixture of large and small nodules, the latter being almost invisible

#### c Distribution

The distribution of nodules on the primary tap and secondary roots is an important parameter which may vary between rhizobium strains and between inoculated and uninoculated plants It is a relative parameter i e , if there are only 5 nodules, but all of them are on the tap root, a "predominant" rating is given (No 3)

PARAMETERS FOR EVALUATING NODULATION

Abundance		Predominant Size	Nodulation on the tap root	Predominant color				
	Rat			Rat			Rat	
More than 100	4		Predominant	3	Black	9	Red and green	4
50-100	3		Medium	2	Red	8	Red and black	3
10-50	2		None	1	Green	7	Brown and green	2
1-10	1	No predominant size	No nodules	0	White	6	No predominant color	1
0	0	No nodules			Brown	5	No nodules	0

Figure 17 1 Reference card for evaluation in the field

Rat = rating S = Stylosanthes, A = Arachis, Z = Zornia,  
D = Desmodium, C = Centrosema, P = Pueraria

Diameter (mm)	1 0	1 5	2 0	2 5	3 0	4 0	5 0	6 0
<u>Stylosanthes</u> , <u>Zornia</u> , <u>Desmodium</u> , <u>Arachis</u>	S	M	L	L				
<u>Pueraria phaseoloides</u>	S	S	S	M	M	L	L	
<u>Centrosema</u> spp	S	S	S	S	S	M	L	L

Figure 17 2 Guide for evaluating the size of tropical forage legume nodules  
S = small (rating 2), M = medium (rating 3), L = large (rating 4)

#### d Internal color

An internal color of red or pink is most common, however, certain strains or environments result in the formation of brownish, black, green, or white nodules. Some nodules contain two colors for example, in the case of Centrosema spp where green and red zones may occur in the same nodule. Approximately 10 nodules, representative of the different size groups, are evaluated on each plant. Split open the nodule with a finger nail to observe the internal color.

For the size and internal color parameters only a predominating characteristic is rated. Thus a category is only given if more than half the nodules on a plant have that characteristic. If this is not the case, category 1 is given (no predominant size or color). Dead nodules are not considered.

If the nodules must be stored they should be kept in the refrigerator. However, even under these conditions the clear colors seen in the field deteriorate.

#### 4 Data analysis

The data on the ratings are analysed using the modified minimum chi-squared test on frequency tables taking each parameter separately. All the data are used for the frequency table in the case of abundance but for size distribution and internal color unnodulated plants are disregarded. If the chi-squared analysis is significant the treatments are divided into groups which appear to be different from each other, and chi squared is tested again for each group. When the chi squared is not significant within the groups, each group is assigned a level as in the following example.

Treatments with over 50% of plants with

more than 50 nodules	= level 1
10-50 nodules	= level 2
0-10 nodules	= level 3

Date of evaluation \_\_\_\_\_

Experiment number \_\_\_\_\_

Treatment	Plant number	Abundance			Size			Nodulation on tap root			Predominant color		
		RI	RII	RIII	RI	RII	RIII	RI	RII	RIII	RI	RII	RIII
	1												
	2												
	3												
	4												
	5												
	6												
	1												
	2												
	3												
	4												
	5												
	6												
	1												
	2												
	3												
	4												
	5												
	6												
	1												
	2												
	3												
	4												
	5												
	6												

Each parameter is analyzed in the same way. Once the levels have been assigned to each treatment for each parameter a table can be made, which describes the nodulation in the whole experiment.

There are computer programs that can be used for this type of analysis. Contact CIAT for more details.

### 17 1 3 Evaluation of nodulation in an established pasture

Choose a site in the pasture that has more than 60% legume cover. Using a 1 m<sup>2</sup> quadrat divided into 25 squares of 20 x 20 cm, estimate the legume cover by using a scale of 1 to 4 for each square. Take a core sampler of 7 cm diameter (see Figure 17 3) and drive it into the soil with a hammer. Take a sample of soil from each row of 5 squares, each one from a different column (see Figure 17 4).

Divide each soil sample into 4 subsamples representing 4 soil depths (0-4, 4-8, 8-12, and 12-16 cm). Count the number of nodules in the 20 subsamples. Repeat in 4 more sites in the pasture that have 60% or more legume cover. In cases where the number of nodules per sample is low, the number of samples per plot can be increased, or the number of plots can be increased.

Record the internal color of the nodules, and specify if the number of nodules counted is total nodule count or only living nodule count. The data can be expressed as nodule number per area, per percentage of legume cover or per plant. In pastures with less than 60% legume cover, nodulation can be evaluated by the method described in 17 1 2.



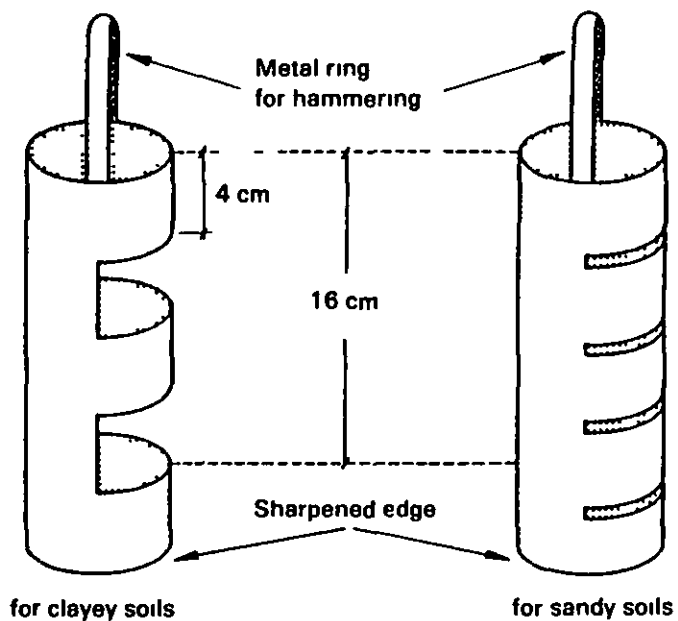

Figure 17 3 Auger for taking soil samples for evaluating nodulation in pastures

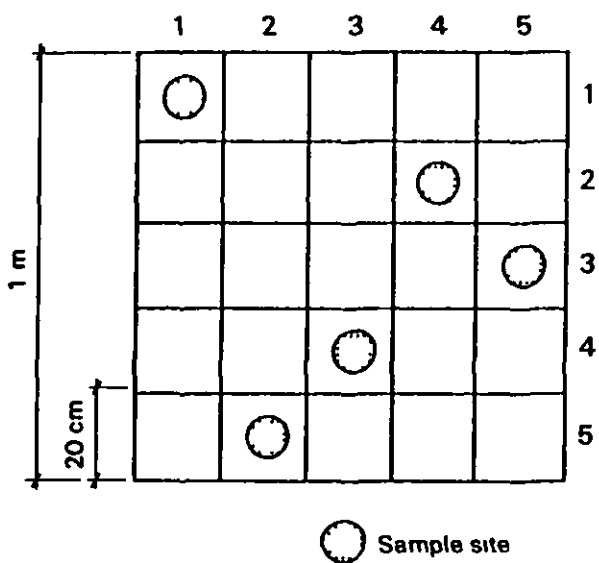

Figure 17 4 Sampling plan

## 17 2 Beans and other grain legumes

### 17 2 1 Nodulation evaluations in greenhouse experiments

It is relatively easy to recover all the nodules from bean plants grown in pots of soil. Wash the roots carefully in a sieve with running water and if possible count the nodules immediately. The roots with nodules can be stored in labelled plastic bags in the freezer if necessary, but they will lose their distinctive color and firm structure. Dead and decaying nodules are not included in the count.

If there are differences in nodule size between treatments, some measure of nodule mass may be useful. Fresh weight, fresh volume or dry weight are three options. Whichever method is used, it will be necessary to pick the nodules off the roots, a very time-consuming job.

For fresh volume and weight it is important that each sample be treated in the same way and the same time period be allowed to pass between washing, picking, and weighing or measuring. Volume is determined by putting the nodules into a small measuring cylinder (FAO 1985). Nodule dry weight is determined after 48 hr at 60 °C, it is absolutely critical that all sand and soil be removed before weighing.

### 17 2 2 Evaluation of nodulation in the field

It is recommended that the roots of at least 6 plants per plot be examined. In the case of climbing and intercropped beans, this may be the maximum number of plants that can be sacrificed while in monocropped bush beans, samples of 8 to 10 plants may be taken.

Excluding the last plant in each row, carefully dig up the next few plants (saving the central part of the plot for yield estimates) Use a shovel and dig around the plant before trying to lift it out Gently separate the roots from the soil, and sift through the soil to recover any nodules that have fallen off

#### 1 Early nodulation

The first evaluation should be done in the second to third trifoliolate leaf stage (V3 to V4) It is fairly easy to recover the entire root system at this stage and the number of nodules per plant should be counted All nodules should be counted, even though many of them will be small and still white in color

#### 2 Evaluation in the mid-flowering stage

Nodule number and mass are generally greatest at mid-flowering (R6) stage and the second evaluation should be made at this time It will be more difficult to dig out the entire root system, especially in the case of climbing beans intercropped with maize, so great patience and care will be required

If possible, the number of "effective-appearing" (i e , red or pink) nodules per plant should be counted In beans, immediately after digging up the plants, nodules with a red to pink internal color can be fairly readily distinguished (without opening them), from those that are green, white or grey, and aging For other grain legumes it may be necessary to open the nodules, as described for forage legumes (see 17 1 2) In very large experiments, or when the plants have many nodules it may be preferable to use a visual-scoring system, using abundance categories instead of counting the nodules

In the CIAT Bean Program, a scoring system of 1 to 9 is used to rate disease resistance, vigor, adaptation, and other characters. Category 1 is used to represent resistant or excellent while category 9 is very susceptible or poor. We have adopted the same system for evaluating nodulation. 1 is excellent, and 9 is very poor (Table 17.2).

The abundance categories used may vary between sites or bean types. Two examples of scoring systems used in CIAT are shown in Table 17.2. The categories are made on the basis of previous experience in the area with a given bean type or by taking samples from several plots (very vigorous and very poor plants) counting the nodules and assigning numbers to the extreme categories. At the CIAT stations in Colombia, bush beans generally have between 10 and 80 nodules per plant, while the climbing varieties often have as many as 250, hence the two scoring systems.

The number of effective-appearing nodules is estimated by glancing across the root system, and a score is assigned. For example, if there are between 20 and 40 nodules on a bush bean, the plant is given a score of 5.

In some experiments nodulation characteristics other than number may be of interest, for example, distribution, size and color. Discontinuous categories as described for pasture legumes can be used, or as it is often the active nodule tissue that is of interest, large variation in nodule size can be accounted for within the system in Table 17.2 by using the intermediate (even-numbered) scores. If the majority of the nodules are medium in size or there is no predominant size, there is no change in the score (only odd numbers are used). However, if there is a predominance of large nodules the score is lowered and if there is a predominance of small nodules the score is raised. Thus a single score for active nodule mass takes into account number, color and size. If the treatments affect the proportion of red and pink nodules it is recommended

Table 17 2 Scoring system for effective-appearing nodules in beans

Score	Number of nodules (red or pink)	Example <sup>a</sup>	
<b>A Bush bean</b>			
1	More than 80		
2*		RN	S
3	41 to 80		
4*		30 large	4
5	21 to 40	30 medium	5
6*		30 small	6
7	10 to 20		
8*			
9	less than 10		
<b>B Climbing bean</b>			
1	More than 240		
2*		RN	S
3	121 to 240		
4*		100 large	4
5	61 to 120	100 medium	5
6*		100 small	6
7	30 to 60		
8*			
9	less than 30		

\* The even numbers are used to modify the scale to account for variation in nodule size. If all the nodules are medium or there is no variation among treatments, only the odd numbers are used.

a RN = red nodules, S = score

that two evaluations be done --one for the apparently effective nodules and the other for total nodules

Data reported in the form of "scores" is best analysed by nonparametric analysis of variance. However, if it is considered that the percentage of change in nodule number or mass between categories is constant, the more common parametric analysis of variance can be used. A similar evaluation method is recommended by Brockwell et al (1982)

### 3 Late nodule senescence

The effect of plant genotype, inoculation or agronomic treatment on nodule senescence may be of interest. In this case a third nodulation evaluation, at mid to late pod-fill is done. It is difficult to get reliable data because the roots are also starting to decay by this time, if effective nodules are present they are likely to be on the lateral roots at a considerable distance from the main stem, and the soil is often drying out at this time making it very difficult to dig up the root system.

# 18 NITROGEN DETERMINATIONS

## 18 1 Determination of nitrogen content in plant tissue

The determination of nitrogen content in plant tissue is important for evaluating responses to N fertilization and to inoculation. Although the dry matter yield can give an indication of the N content, the relationship between the two parameters is not necessarily linear. The following method for N determination is taken from Salinas and García (1985)

### 18 1 1 Plant tissue samples

Before chemical analysis plant samples generally undergo the following four preparatory steps (Steyn, 1959, Jones and Steyn, 1973)

1 The material is cleaned to remove superficial contamination. Plant material is always covered with a layer of dust that may affect the results of the analysis. However, in the case of the analysis of nitrogen in plant tissue, contamination from dust is generally insignificant. Levels of N in the tissue are very high when compared to those in soil. The effect of contamination can be significant in the case of Ca, Al, Mg, Si, and even Fe and Mn, the levels of these elements are relatively low in plant tissue when compared to soil.

2 The material is dried to constant weight at 60 °C to stop enzymatic reactions from occurring and to determine dry matter production.

3 The material is ground mechanically to the appropriate particle size for chemical analysis. A Wiley mill with a 1 mm stainless-steel mesh grid works well. Before grinding it may be necessary to reheat the samples.

4 The dried, ground plant-tissue samples are put in plastic containers (25 g minimum capacity) and sealed to prevent any change in moisture content Each container should be labelled If the containers are not sealed, the samples must be redried before they are analyzed

## 18 1 2 Nitrogen determination (%)

### 1 Materials

Digestion tubes, digestion blocks at 370 °C, microdistiller, 50-ml burette and 125-ml Erlenmeyer flasks

### 2 Reagents and their preparation

- a 50% Sodium hydroxide in water
- b Indicator mix Weigh 0.5 g of bromocresol green indicator and 0.1 g of methyl red indicator, dissolve in 100 ml of 96% ethyl alcohol
- c Boric acid solution at 4% To each liter of this solution add 5 ml of indicator mix
- d HCl 0.02 N Prepare 1N HCl then take 20 ml and dilute with double deionized or distilled water to 1 liter
- e Concentrated sulphuric acid
- f Catalyst Mix 0.5 g selenium and 100 g  $\text{Na}_2\text{SO}_4$  until it stays well compacted Another catalyst that can be used is a mixture of 0.10 g  $\text{CuSO}_4$  and 5 g  $\text{Na}_2\text{SO}_4$



### 3 Procedure

- a Weigh out and place 0.1 g of the plant sample in a digestion tube and add the catalyst ( $\pm$  1 g)
- b Add 4 ml concentrated sulphuric acid and digest in the blocks at 370 °C for 30 minutes
- c Allow to cool and add a little deionized water  
Quantitatively pass the tube contents to a microdistiller rinsing with deionized or distilled water
- d Add 20 ml of sodium hydroxide solution (50%) and distill, collecting the distillate in 4% boric acid solution
- e Titrate the distillate with 0.02 N HCl to obtain a clear-grey color
- f Prepare and titrate a control that contains all the reagents except the sample, the volume added in the titration of this control should be subtracted from the volume added to the samples, in the calculations

### 4 Calculations

$$N (\%) = \frac{V - B}{1000} \times 0.02 \times 14 \times \frac{100}{0.1}$$

$$N (\%) = 0.28 (V - B)$$

where

V = Volume of 0.02 N HCl added to the sample (ml)

B = Volume of 0.02 N HCl added to the blank (ml)

$\frac{V - B}{1000}$  = net volume converted to liters

0.02 = normality of the HCl

14 = equivalent weight of N (g)

100 = percent relation

0.1 = weight of the sample (g)

## 18 2 Determination of mineral nitrogen content in soil

In general, mineral N determinations give a better estimate of plant available N than total soil N content (Page et al , 1982) There are two general methods to estimate available mineral nitrogen

### 18 2 1 Indirect (plants)

Biological methods can be used in which the N taken up by a plant serves as an indicator of the available soil nitrogen Plants differ in their ability to utilize nitrogen, thus those efficient in N uptake are chosen, such as lettuce, maize or Panicum maximum After a given period of growth the plants are harvested, and dry weight, N content, and N yield are determined If the plants do not show N deficiency symptoms, legume N<sub>2</sub> fixation may be inhibited and cannot be evaluated by the methods described in this manual

### 18 2 2 Direct (incubated soil)

Incubation methods are used to evaluate the capacity of a soil to provide nitrogen to crops during the growth season This method consists of incubating a soil sample and evaluating the quantity of mineral N that accumulates over time The samples are incubated under laboratory or greenhouse conditions, they can be treated or not during the incubation To avoid changes in soil density etc , samples can be taken in PVC cylinders, and maintained at initial moisture levels during the incubation period In the absence of leaching and absorption by plants, rates of mineral N accumulation are observed, they vary between soils and between treatments of the same soil

This technique has the advantage that it does not require more than about 10 days to obtain results However, it is necessary to freeze the samples or take other measures to avoid changes in mineral N content before analysis The analysis of NO<sub>3</sub><sup>-</sup> is done on aqueous extracts of soil and NH<sub>4</sub><sup>+</sup> on 1 N KCl extracts The

samples should not be dried before beginning the analysis, as this may liberate  $\text{NH}_4^+$ . If more than 1 ppm of mineral N accumulates in the soil per day it is not possible to evaluate  $\text{N}_2$  fixation by legumes as described in this manual

### 1 Analysis of $\text{NO}_3^-$

- a Nitrate is easily extracted by washing once in water

Weigh out 10 g of soil, and add 0.5 g  $\text{Ca}(\text{OH})_2$  and 50 ml of water, mix for 15 minutes and then filter

- b Take a 25 ml aliquot and evaporate to dryness (70 °C for 24 hr)

- c Add 3 ml phenoldisulphonic acid<sup>1</sup>

- d Put in a 100 ml volumetric flask with about 25 ml of water

- e Add about 15 ml of 7N NaOH (until a yellow color appears)

- f Complete to 100 ml with water, cool and read at 420 nm in a colorimeter

- g Compare with a standard curve prepared with known concentrations of  $\text{NO}_3^-$ , from 0-40 ppm

### 2 Analysis of $\text{NH}_4^+$

- a Ammonium requires a more vigorous extraction using  $\text{K}^+$ , which substitutes it on the clay particles

Weigh out 10 g of soil and add 50 ml 1N KCl

Mix 30 minutes and filter, wash 5 times with 10-ml volumes of KCl

Complete to 100 ml in a volumetric flask

---

1 This acid is prepared as follows: 104.9 ml of phenol + 1 liter concentrated  $\text{H}_2\text{SO}_4$  (or 111.1 g of solid phenol + 1 liter concentrated  $\text{H}_2\text{SO}_4$ ) Warning! phenol is carcinogenic

b There are several methods for determining  $\text{NH}_4^+$  content (Page et al , 1982) The distillation method described for plant-tissue analysis can be used

- Begin at step d in the procedure in 18 1 2 3 but change the quantity of 50% NaOH that is added to the 100 ml of extract from 20 ml to 5 ml Distill, collecting the distillate in 4% boric acid
- Titrate as described above (18 1 2 3, e and f )

# 19 INSTRUCTIONS FOR EXPERIMENTS WITH INOCULATED TREATMENTS

(Stage 2)

Stage 2 experiments use the same plant growth and evaluation systems as Stage 1 experiments. These methods are described in Chapters 13-18.

In Stage 2, inoculation treatments are introduced, and it is necessary to take some added precautions with these treatments. In this chapter the necessary precautions and inoculation methods for field and greenhouse trials are described.

## 19 1 Inoculation experiments in the greenhouse

### 19 1 1 Experimental design

In the greenhouse completely randomized designs are often used. If there is a gradient in the greenhouse, or in the case of soil cores where the blocks represent different weights, randomized block designs are used. Any number of strains, soils or genotypes can be evaluated in this way.

### 19 1 2 Precautions for preventing contamination between treatments

Before planting an experiment it is important that the pots or PVC tubes be washed and then soaked for an hour in 0.5% sodium hypochlorite solution. This will prevent any contamination from previous trials.

During an experiment wash hands and any instruments with alcohol or other disinfectant (for example benzalconium chloride) and be sure irrigation water is not contaminated with soil.

After germination an irrigation tube is placed in the soil in each pot or core and the remaining surface is covered with a layer of waxed sand. (See 13.5 for preparation method). This layer of sand helps prevent contamination between treatments and also maintains soil moisture.

### 19 1 3 Inoculation

Seeds can be inoculated and planted using the same methods as are used in field experiments (see 19 3) Care should be taken to ensure that more or less the same number of rhizobia per seed is added in all treatments A minimum of 300 cells per seed should be applied, but this can be increased up to  $10^4$  cells/seed

A second alternative is to pregerminate seeds, and at the time of planting 0.1 g of inoculant or 0.5 ml of cell suspension is put under each seed

A third option is to wait until after the plants have been thinned and then inoculate with 0.5 ml of cell suspension The advantage of this option is that any pots with poorly germinated seedlings can easily be discarded and replaced if some extra pots have been planted

### 19 1 4 Harvest and data analysis (Stage 2, greenhouse)

The nodulation is evaluated and the tops are harvested, dried, ground, and analyzed for % nitrogen as described in Chapters 13, 14, 17 and 18 In most cases N yield data can be compared directly by analysis of variance

Another method is to evaluate the effects of inoculated treatments on N yield with the "inoculation effectivity index" (IEI), defined as

$$IEI = \frac{N \text{ yield (+I)} - N \text{ yield (-I)}}{N \text{ yield (+I)}} \times 100$$

This index evaluates the relative effectivity of a strain compared with the uninoculated control, and can be used to compare the effectivity of various strains or inoculation treatments The N fertilized treatment is evaluated using the nitrogen response

index (NRI) described in Chapter 13. If the IEI is similar to the NRI the inoculated treatment can be considered effective. The IEI is particularly useful for comparing data taken at different times during the growth curve, and in Stage 3 experiments.

## 19.2 Inoculation experiments in the field

### 19.2.1 Experimental designs

The field trials proposed here include treatments which are uninoculated, inoculated, and fertilized with N. With these treatments, the effectiveness of native strains and of inoculated strains can be evaluated. To ensure success in these experiments mineral N availability must be minimized using reduced tillage (Chapter 15), or other methods (Chapter 16). If yield is good in all treatments, but nodulation is poor, N is not limiting growth and methods for minimizing soil N must be improved. It is expected that a nitrogen response would be observed (a difference in nitrogen yield between the uninoculated and high N treatments) in those cases in which response to inoculation is sought. If there is no nitrogen response and the uninoculated plants are well nodulated, this lack of response is likely due to the effectiveness of the native strains. The lack of an N response when the plants are not well-nodulated and yield is poor indicates that either the legume is poorly adapted or the levels of other nutrients are inadequate. A response to N but not to inoculation may be due to a lack of adaptation of the inoculated strains to local conditions, to poor quality inoculant, to a low number of rhizobia per seed or to poor ability of the legume genotype to fix  $N_2$ . If there is a good response to inoculation and to N, it can be concluded that the inoculated strains are effective under local conditions.

#### 1 Forage legumes

For general instructions on trial establishment in the field with forage legumes refer to Chapter 15. It is recommended

that in Stage 2 inoculation responses only be evaluated during the establishment phase (a maximum duration for the experiment of 6 months) for several reasons. It is more useful to study many legumes and strains during the establishment phase, than to evaluate fewer materials over longer periods. As contamination between plots is likely to occur over time, results of long-term experiments are not reliable unless the strains in each plot can be identified (using serological methods). Also the performance of rhizobium strains may be quite different in plots maintained by cutting than in a grazed pasture.

A simple experiment that can be set up to evaluate the inoculation response to three rhizobium strains during legume establishment, including the two controls (without inoculation and fertilized with N), would give a total of five treatments. At least one recommended strain should be included, the others can be locally isolated and tested strains. It should be noted that a mixture of strains may be less effective than some of the individual strains (see CIAT Annual Report, 1984). Therefore the use of mixed strain inoculants is recommended only if treatments of the strains inoculated individually are included.

For an experiment with only five treatments the furrows can be arranged as shown in the plan in Figure 19.1. However for a larger number of treatments it may be preferable to use plots with 6 furrows 3-m long rather than 3 furrows 6-m long, to avoid the block becoming too narrow and long (see 15.3). The alleys between plots should be at least 2 m, and if possible 3-m wide, and should contain drainage ditches.

## 2 Grain legumes (beans)

For general instructions on bean trial establishment in the field refer to Chapter 16. The design and size of experiments to test the response of beans to inoculation will depend on the cultivation system: climbing or bush beans, monoculture or intercropped. Randomized block designs with a minimum of 3 repetitions per treatment are recommended.



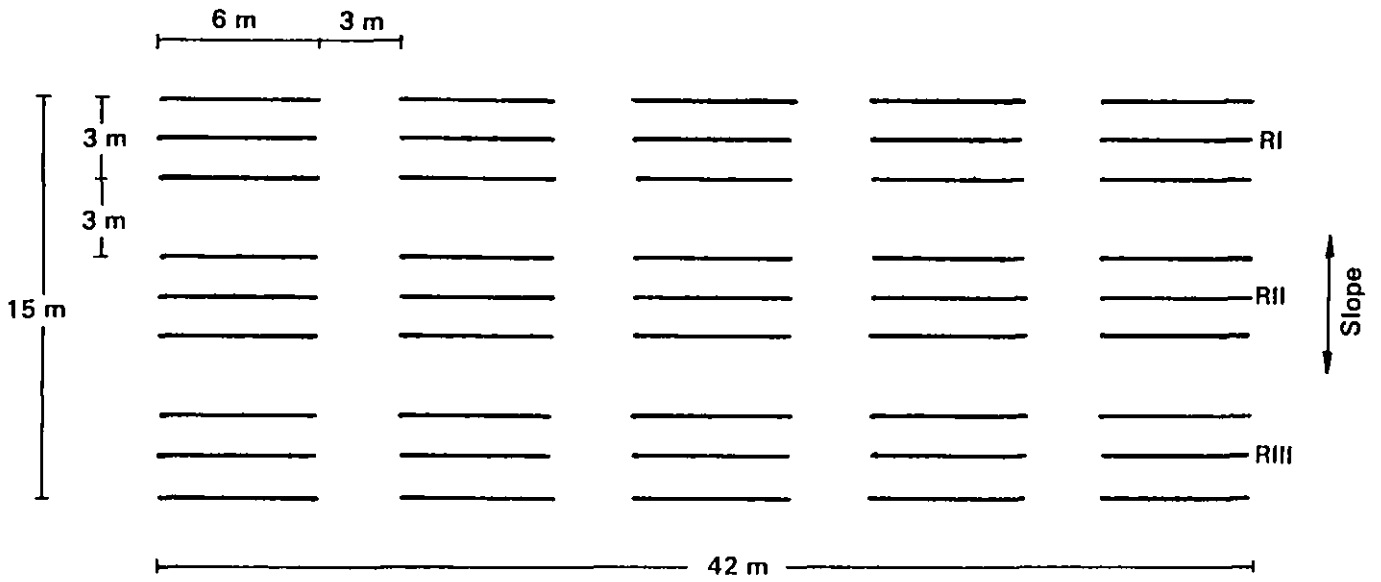

Figure 19 1 Field design of a forage legume experiment with five treatments

Two or more rows planted between the plots help to minimize contamination between inoculated strains and the leaching of N from the +N to the low N treatments. Also if alley rows are planted, the entire plot can be harvested, if necessary, instead of only the center rows.

Plots of 5 rows by 4 m are appropriate for bush beans in monoculture but it is necessary to have larger plots if beans are grown in association with maize (see Figures 19 2 and 19 3).

#### 19 2 2 Precautions to avoid contamination between field plots

It is essential that contamination between plots be avoided. Always use different tools and containers for each treatment and wash these materials and your hands (with water and alcohol or other disinfectant) before passing from one treatment to the next. It is especially important to avoid contaminating the uninoculated treatments, therefore it is wise to begin the experiment with the uninoculated treatments and then proceed to the inoculated ones. Cover feet with plastic bags before entering each plot, remove the bags when leaving and hang them on a stake for future use. It may be necessary to include wide alleys and ditches between the plots to avoid contamination caused by rainwater flowing between plots.

#### 19 2 3 Management of inoculants in field trials

Follow the inoculation instructions given in 19 3 to 19 6. For inoculation experiments in CIAT, forage legume seeds are pelleted (19 3 1) and soil inoculation (19 3 2) is used for beans. However, it may be necessary to compare different inoculation methods for a specific situation (see Chapter 20). The inoculant should be prepared in a sterile carrier if possible and the quality evaluated (using the plate-count method) about two weeks before planting, so that it can be prepared again in the case of

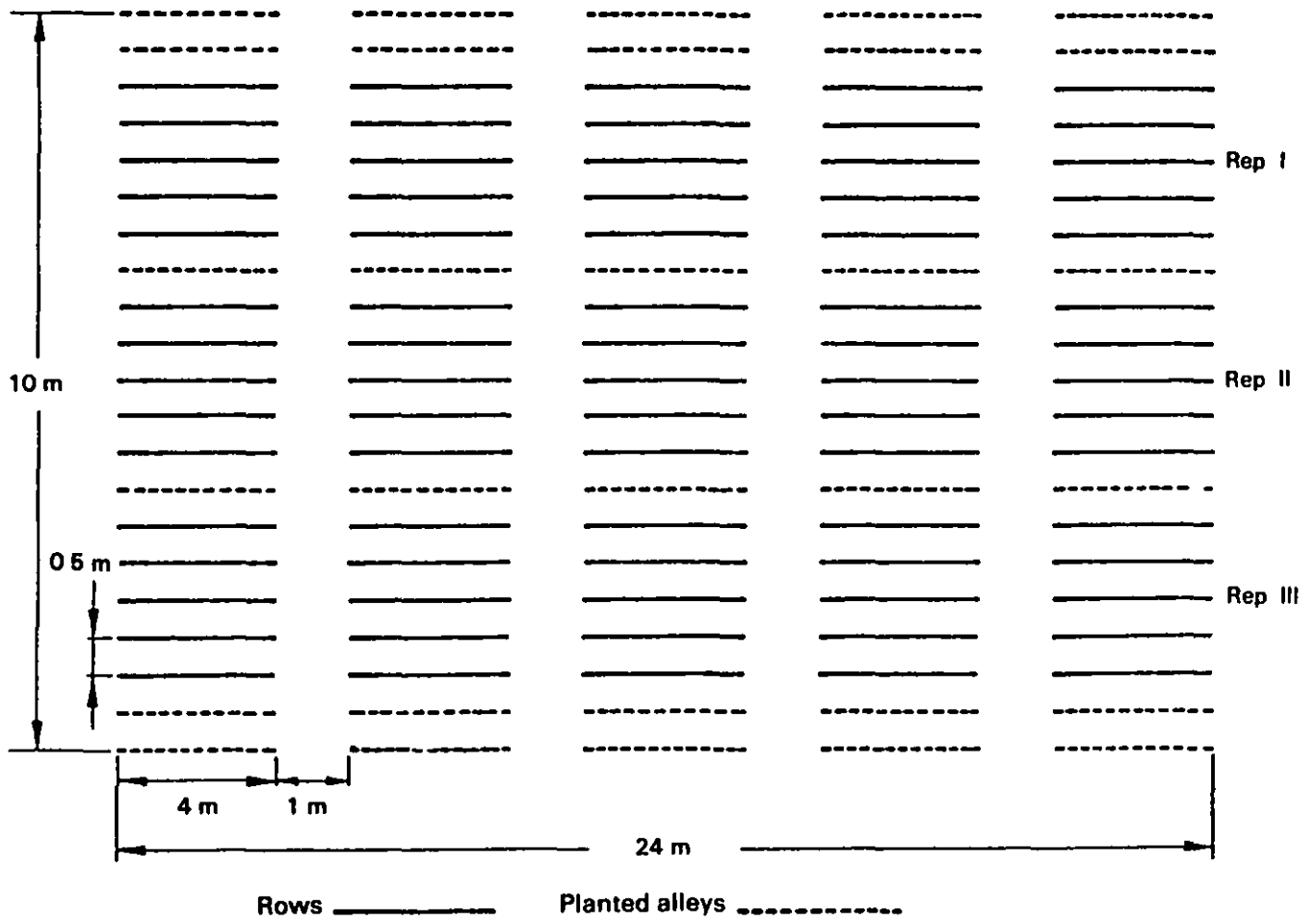
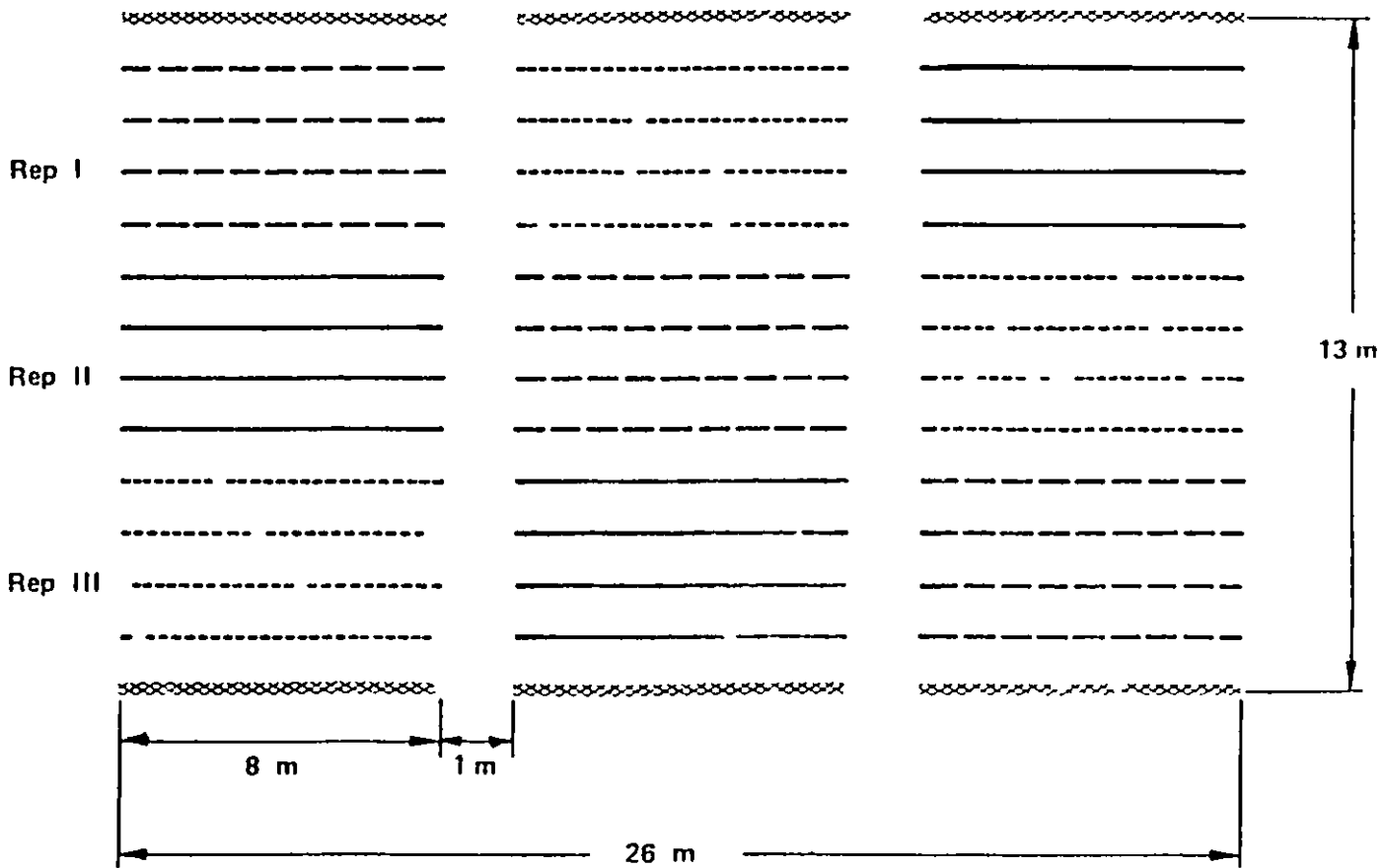

Figure 19 2 Field design of a monoculture bean experiment with five treatments without inoculant, high N and three strains of rhizobia



**Figure 19 3** Field design of a bean/maize association experiment with three treatments without inoculant high N and inoculated with one strain of rhizobium

poor-quality inoculant A good quality inoculant should have at least  $10^9$  rhizobia per g If inoculant quality cannot be evaluated, it is best that it be prepared separately for each repetition, to reduce the risk of having low quality inoculant in all repetitions

#### 19 2 4 Harvest and analysis

Harvest, tissue analysis, and the evaluation of nodulation is performed following the instructions given in Chapters 15, 16 17, and 18 Data are analysed using analysis of variance and the IEI as described in 19 1 4

#### 19 3 Inoculation in the field

##### 19 3 1 Seed inoculation with peat-based inoculant

The seeds can be inoculated by simply mixing the inoculant with water and adding it to the seed, but the number of rhizobia per seed is higher if the inoculant is stuck to the seed with an adhesive, and then covered with a protective coat of rock phosphate, charcoal, or lime This coating of the seeds is called "pelleting" and the seed thus treated called a "pellet " Rock phosphate is the pelleting agent normally used for tropical forage legumes For beans and Leucaena, lime is recommended

As molybdenum is required for  $N_2$  fixation and may be deficient the response to inoculation may be increased if  $MoO_3$  or ammonium molybdate is added to the pelleting material (1 3 proportion)  $Na_2MoO_4$  cannot be used as a source of Mo in the pellet because it is toxic when in direct contact with rhizobia (Kerridge et al 1973)

The adhesive most appropriate is ground gum-arabic which is available in drug stores in many countries "Polvillo de mandioca" (cassava starch) has been used as a substitute in Brazil

(Seiffert and Miranda, 1983, Faria et al , 1985), also, a solution of 5% methylcellulose can be used Sugar may have a positive effect on rhizobium survival on seeds (Burton, 1976) For more details see Roughley (1970) and Brockwell (1982)

Seeds should be inoculated the same day as planting If for some reason the inoculated seeds cannot be planted, they must be washed, dried and reinoculated on the planting day It is advisable to inoculate the seeds at dawn, to allow time for early planting and for doing the quality control counts Include additional seeds in the treatments from which samples for counting are to be taken For example, if the sample is of 10 seeds, before inoculation, add 10 seeds for each plot

It is recommended that seeds for each plot be inoculated and evaluated separately In this way the risk of error in the inoculation procedure is covered Also if all the seeds for one treatment are inoculated together it is difficult to separate the quantities required for each plot because of the change in seed weight due to inoculation

The necessary steps for inoculating forage legume seeds using gum arabic as the adhesive are as follows (see Figure 19 4)

#### 1 Seed preparation

Seeds with hard testa should be scarified before inoculation  
Seeds treated with fungicides should be washed in water and then dried before being inoculated

#### 2 Preparation of adhesive

Prepare a solution of gum-arabic, at least one day before it is needed, by adding 40 g of gum to 100 ml of clean water (8 tablespoons of gum for 10 of water) and leave the mixture to dissolve for 12 hours It will dissolve more quickly in hot



**1.** If the seeds are treated with a fungicide wash and dry them

One day before planting

**2** Prepare a solution of gum-arabic (40%) in hot water  
(4 level tablespoons of ground gum for every five tablespoons of water)

On planting day

### 3. Inoculation

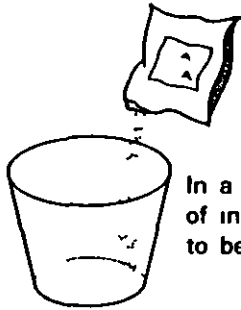

In a clean bucket put 50 g of inoculant per kg of seed to be inoculated

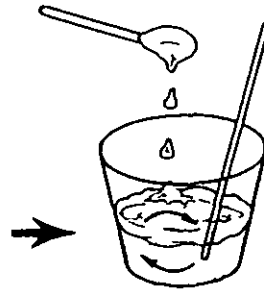

Add approximately 30 ml (3 tablespoons) of solution of gum for every 50 g of inoculant and mix well

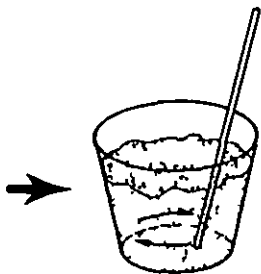

Add the clean seeds and mix well until the gum begins to dry (the seeds separate from each other)

### 4. Pelleting



Add 300 400 g of rock phosphate or 100 150 g of ground charcoal and gently mix with the hand while rotating the bucket to cover the seeds well

### 5 Planting

Plant as soon as possible (less than 24 hr) taking care that the seeds do not get warm

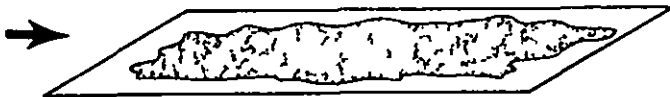

Spread the seeds in a shaded area to dry for 15 20 minutes

Figure 19 4 Inoculation of forage legume seeds

water The solution is perishable and should be refrigerated or prepared fresh before each planting It should be sterilized if plate-counts are to be made

### 3 Inoculation

On the day of planting, or the night before, put 50 g of inoculant per kg of seeds to be inoculated, in a clean bucket or similar container<sup>1</sup> When inoculating mixtures of strains, it is important to keep the packets of inoculant of each strain separate until the moment of inoculation Equal quantities of each one of the strains is used to give a total of 50 g inoculant per kg of seed Add about 30 ml (3 tablespoons) of the gum-arabic solution for each 50 g of inoculant (12-14 drops of gum per 1 g inoculant) to the inoculant in the container Mix well, and then add the seeds Continue to mix until the seeds stop sticking to each other

### 4 Pelleting

To the inoculated seed and all at once, immediately add 300-400 g of rock phosphate or 100-150 g ground charcoal (the amount will depend on the seed size but should be in excess so some remains in the bucket after pelletting) A mixture of  $\text{MoO}_3$  with rock phosphate 1:3, or 500 g of  $\text{CaCO}_3$  per kg of seeds can also be used In the case of Stylosanthes spp, a negative effect of phosphorus on inoculation response has been observed, possibly due to inhibition of mycorrhizae Thus charcoal should be used rather than rock phosphate Turn the container gently until each seed is covered with a firm layer A seed that is well pelleted is completely covered by the rock phosphate, charcoal, or lime Leave the pelleted seeds in the shade for

---

1 With large-seeded legumes (for example bean, soybean, and Leucaena) the quantity of inoculant/kg can be reduced (5-30 g inoculant/kg seed)



about 20 minutes to allow the coating to dry and harden. This is important to prevent the pellets from peeling off later.

## 5 Planting

The pelleted seeds should not be stored for more than 12 hours before planting, as the rhizobia may lose their effectiveness due to toxins produced by the seed, or to drying of the cells. The seeds should be kept away from heat, and if possible, covered with soil immediately after planting.

## 6 Counting rhizobia on inoculated seed

If it is impossible to count rhizobia on the seeds before planting, this step can be omitted. However it is recommended that it be included as it facilitates interpretation of the results. On planting day, samples of inoculated seeds are taken and rhizobia counted according to the instructions given in Chapter 11. Inoculant in sterile carrier is preferable as this permits the count to be done using the plate-count method which is simpler than the most probable number (MPN) method (see Chapter 10). If using the plate-count method, seeds should be inoculated in sterile containers (new disposable cups can be used) and the gum-arabic and rock phosphate have to be sterilized as they contain many fungi. Sterile peat may be requested from CIAT.

### 19 3 2 Use of granular inoculants

Granular inoculants are prepared using coarsely ground and sieved peat (40 mesh) or other carrier. They are recommended for use when seeds have been treated with pesticides, when very high rates of inoculant application are desired, as in the case of large native rhizobium populations, and when many lines of the same species are being planted.

Inoculant is sprinkled in the furrow at a rate of 0.1-1 g inoculant per meter of row, for lower inoculation rates the inoculant may be mixed with sawdust or other inert substance to facilitate its distribution. The seeds are put in the furrow and then covered immediately with a little soil. High inoculation rates of up to  $10^8$  rhizobia per m are easily achieved. If fertilizer is being applied at the time of planting, it can be put in the same furrow and covered with a little soil before inoculation, or it can be applied in a band beside the furrow. If the seed is sown in a hole rather than a furrow (as is common with climbing beans), 0.5 to 1 g of inoculant is placed together with the seed in the hole.

Multiple strain inoculants should be mixed immediately before sowing, and as with all inoculants samples should be taken for quality control checks. The granular inoculant should be stored in the refrigerator if possible, and inoculation carried out during the cool period of the day. Otherwise no special steps are required.

### 19.3.3 Use of freeze-dried inoculants sent by CIAT

In the cases where conditions are not adequate for inoculant preparation locally, freeze-dried inoculants may be requested from CIAT. These inoculants can be used in three ways:

- Reconstituted in sterile peat
- Suspended in mineral oil
- Suspended in water

For strain evaluation experiments and regional trials it is recommended that the inoculant be reconstituted in peat and used according to the instructions in 19.3.1 and 19.3.2, at least until more detailed information is available on the use of the inoculants in oil.

## 1 Reconstitution and preparation of inoculants

The freeze-dried cells are supplied in ampoules (0.1 ml cell concentrate) or serum vials (1-ml cell concentrate). One ampoule should contain enough cells ( $10^9$ ) to reconstitute 7.5 g of inoculant and the vials sufficient ( $10^{10}$ ) for 75 g of inoculant. Appropriate quantities will be sent according to the amount of seed to be sown. Sterile peat will be provided (in 5 g or 50 g bags) together with sterile syringes. Users should obtain their own sterile water. Table 19.1 summarizes the reconstitution procedure.

When using sterile peat, if sterile conditions are used for preparation (sterilized water, containers, etc.), to avoid the introduction of fungi, the quality of the inoculant will improve over 1-2 weeks kept at room temperature (25-30 °C), due to growth of the rhizobia in the peat. This inoculant can be stored in the refrigerator (4 °C) for up to 6 months.

## 2 Suspension in mineral oil

Serum vials are distributed containing the freeze-dried cells suspended in mineral oil. The vials also contain two glass beads for mixing. To use the inoculant, mix well, open the vial and apply the contents to 1 kg of small seeds or 10 kg of large seeds. Stir well and plant as soon as possible.

## 3 Suspension in water

The freeze-dried inoculants can be suspended in water and applied by spraying (see 19.3.4).

Table 19 1 Reconstitution of inoculants from freeze-dried cells

Cells in ampoules of 0.1 ml	Cells in vials of 1 ml
1 Sterilize distilled or tap water in screw capped or aluminum foil-covered bottle in autoclave or pressure cooker, for at least 15 minutes and cool it <sup>a</sup>	1 Sterilize distilled or tap water in screw capped or aluminum foil-covered bottle in autoclave or pressure cooker, for at least 15 minutes and cool it <sup>a</sup>
2 Break the ampoule in the center of the cotton plug using a file	2 Clean surface of 50 g packet of peat with alcohol Inject 20 ml sterile water into packet using a sterile syringe with a long needle
3 Inject 0.5 ml of sterile water (room temperature) to the ampoule, using a sterile 5 ml syringe with a long needle (use a different syringe for each strain )	3 Inject air into the vial (use a different syringe for each strain )
4 Mix the cells with the water and remove them with the syringe	4 Inject 2 ml sterile water (room temperature) into the vial using the same syringe
5 Introduce more water into the syringe to complete 2.5 ml	5 Mix the cells with the water and remove them in the syringe
6 Clean surface of 5 g peat packet with alcohol Inject the cell suspension	6 Inject the packet of peat with the cells through the same hole
7 Manipulate packet in the hands to ensure that the cells and the peat are well mixed Mark the packet with the strain number and date of preparation Cover hole with tape after 1 week	7 Manipulate packet in the hands to ensure that the cells and the peat are well mixed Mark with the strain number and the date of preparation Cover the hole with adhesive tape after 1 week
8 Keep in refrigerator (4 °C) Use within 6 months of preparation	8 Keep in refrigerator (4 °C) and use within 6 months of preparation

a Water boiled for 30 minutes in a covered container can be used although it may not be completely sterile In this case the inoculant should be used immediately

#### 19 3 4 Use of liquid inoculants

Liquid inoculant can be used to inoculate soil before or after planting and to inoculate vegetative material. It is less effective than seed inoculation and doses of at least  $10^6$  cells per meter of row are recommended. For inoculating one hectare with 0.75 m between furrows, suspend 10 vials of lyophilized inoculant or 1000 g of peat inoculant in a large volume of chlorine-free water (100-150 liters per ha). Using a back-pack sprayer apply in the furrow before planting or along the row of seedlings just after emergence. For areas of 0.1 ha, a vial containing lyophilized inoculant (1 ml) or 100 g of peat-based inoculant are used.

To plant vegetative material, for example, Arachis pintoii, about 150 plants or stolons are needed for each 100 m of furrow, 0.05 g inoculant is used per stolon. They can be inoculated as follows: mix 1000 g inoculant with 600 ml gum arabic solution and add sufficient non-chlorinated water (about 20 l) to mix this well with the vegetative material needed for 1 ha (furrows 0.75 m apart). It is easier to inoculate smaller quantities, e.g. for 500 m of furrow, 37.5 g inoculant (half a 75 g packet), 20 ml gum (2 tablespoons) and 0.75 l water (3 cups). The inoculant is mixed with the vegetative material immediately before planting.

#### 19 4 Recommended strains

In Appendix C (Table C-1) various serologically distinct strains for forage legumes are listed, they have been shown to be effective in the Carimagua soil in the Eastern Plains of Colombia. Listed in Table C-2 are recommended strains of Rhizobium leguminosarum biovar phaseoli. They have been tested for effectiveness in acid soils and hot and cold climates. Tables C-3 and C-4 contain the strains recommended by CIAT for

tropical pasture regional trials Various strains recommended by other institutions are listed in Table C-5

Some strains (ser = ) are serologically identical It is suggested that for inoculation experiments a recommended strain for each legume being evaluated should be included (Tables C-3, C-4, and C-5), and if possible two of the strains included in Tables C-1 and C-2, which are serologically different

These strain lists are revised every year If you intend to set up a strain evaluation experiment, up-to-date lists and strains may be obtained from CIAT

# 20 EVALUATION OF THE EFFECTS OF AGRONOMIC MANAGEMENT ON THE SYMBIOSIS

(Stage 3)

Once the best yielding legume-rhizobium combinations under low N but otherwise optimal conditions in Stages 1 and 2 have been selected, it is necessary to evaluate inoculation responses and/or yield of selected genotypes under farmers' conditions (Stage 3). These experiments should be carried out in parallel to later stages of legume selection. When the improvement in the symbiosis is not expressed on farm, further experiments should be done to explain the effects observed and to make more relevant recommendations. Some agronomic management practices may affect N mineralization which complicates the interpretation of the results of experiments which evaluate interactions between management factors and inoculation responses. However, if N mineralization is measured in the different treatments, as described in Chapter 18 it can be seen whether higher mineralization rates coincide with smaller inoculation responses. When it is expected that the factors being studied may affect N mineralization, it is suggested that a control where the N mineralization rates are low should be included, with and without inoculation.

## 20.1 Inoculation methods

Inoculation methods are unlikely to affect N mineralization rates. Uninoculated and N-fertilized controls are included, together with treatments using different methods of inoculation with the same strain. For example

- Soil versus seed inoculation
- Types of inoculant

Freeze dried

Conventional with different supports (charcoal, soil, rice or cotton husks)

- Effects of fungicides on inoculation response

At the moment of planting the number of rhizobia per treatment should be determined to permit correct interpretation of the results

## 20 2 Tillage methods and monoculture vs mixed cropping

Tillage and cropping systems probably will affect mineral N availability, and therefore the inoculation responses observed

Experiments can be done (using strains which have been shown to be effective under minimum N availability conditions in Stage 2) comparing different sowing methods used by local farmers Each sowing method (main plot) is evaluated with and without inoculation (subplots) An experiment of this type is described by Sylvester-Bradley and Mosquera (1985), where the inoculation response was greater with reduced tillage than with conventional tillage

## 20 3 Fertility levels

It is known that fertility levels in tropical soils, especially P and Mo, and acidity, affect legume N<sub>2</sub> fixation Usually farmers use low fertilization rates Thus it is important to evaluate the interaction between inoculation responses and fertilization rates used by farmers

The San Cristobal design was developed to evaluate the effect of three nutrients with only 12 treatments (Salinas and Goedert in press) Two levels of each nutrient are evaluated in a factorial design (8 treatments), and in four additional treatments some combinations of two extra levels of each nutrient are evaluated



Treatment No	Nutrient level		
	P	K	Mo
1	0	0	0
2	1	0	0
3	0	1	0
4	0	0	1
5	1	1	0
6	1	0	1
7	0	1	1
8	1	1	1
9	0 5	0 5	0 5
10	1 5	0 5	0 5
11	0 5	1 5	0 5
12	0 5	0 5	1 5

In this example, one legume is studied. All twelve treatments are inoculated with a recommended strain, and four of the fertilization treatments are chosen for establishment in addition without inoculation. In this case treatments 3, 5, 7, and 8 could be chosen, to give a total of 16 treatments per legume. It would be necessary to increase the size of the plots to have sufficient plants for nodulation evaluations, and widen the alleys between plots to prevent contamination.



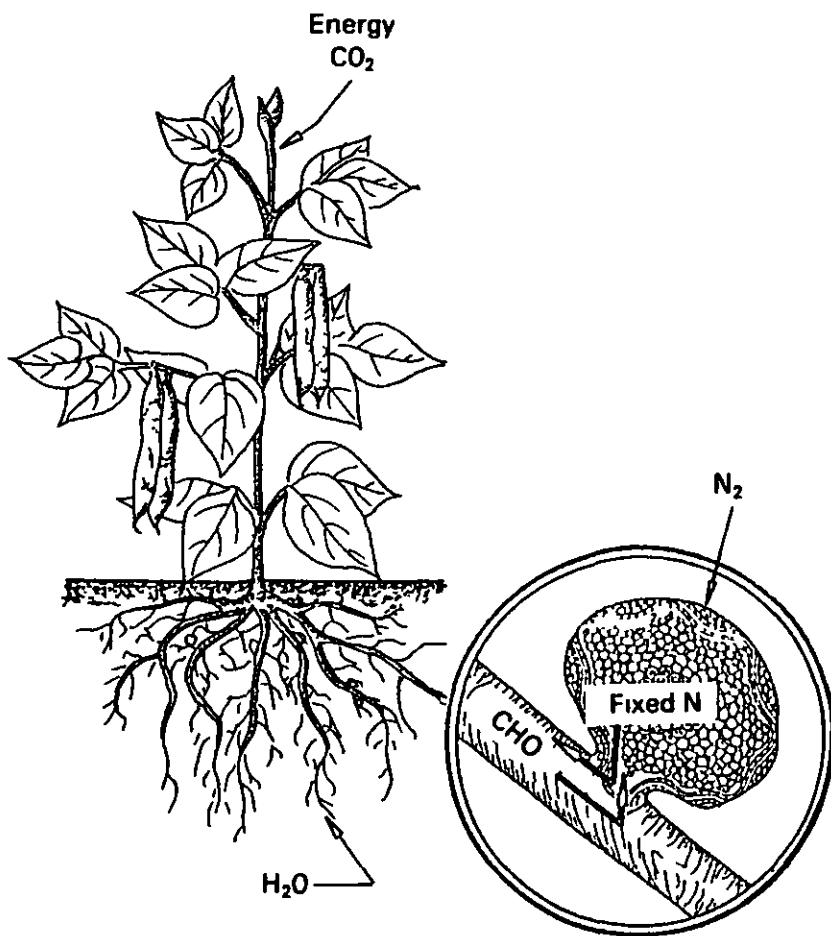

## **Appendices**

# Appendix A

## CONSTRUCTION OF A STERILE HOOD (NIFTAL design)

This hood is a less costly alternative to the laminar flow hood and is more effective than the transfer chambers with ultraviolet light that are commonly used in microbiology laboratories, in which unsterile air flows into the chamber while working. In the design described here, air enters the chamber through the hole that holds the Bunsen burner, as it passes the flame it is sterilized, it circulates through the chamber and leaves through the front opening (see Figure A-1). Take care to empty the gas line and disconnect the gas when the hood is not in use, to avoid possible explosions.

The height of the hood should be adjusted to permit comfortable use of pipettes (i.e., it should sit on a high table).

### Components of the hood

- 1 Back made of plywood, hardwood and glass (0.2-0.5-cm thickness) (Figure A-2)
- 2 Bottom made of plywood with formica surface, includes 1.5-2-cm-diameter hole for bunsen burner
- 3 Top made of plywood
- 4 Reinforcement made of hardwood or plywood, serves as anchor for the door
- 5 Door made of plate glass with hardwood frame, is attached to the reinforcement plate by hinges
- 6 Two sides made of plywood
- 7 Eight wooden moldings to hold glass for the door (90 and 44 cm long)

8 Eight wooden moldings to hold glass for the back window (90 and 51 cm long)

9 Four wooden legs 10-cm high

The plywood used should be 15-20 cm thick with a smooth finish on both sides. The chamber should be painted with a hard coated, smooth oil-based, epoxy-type paint.

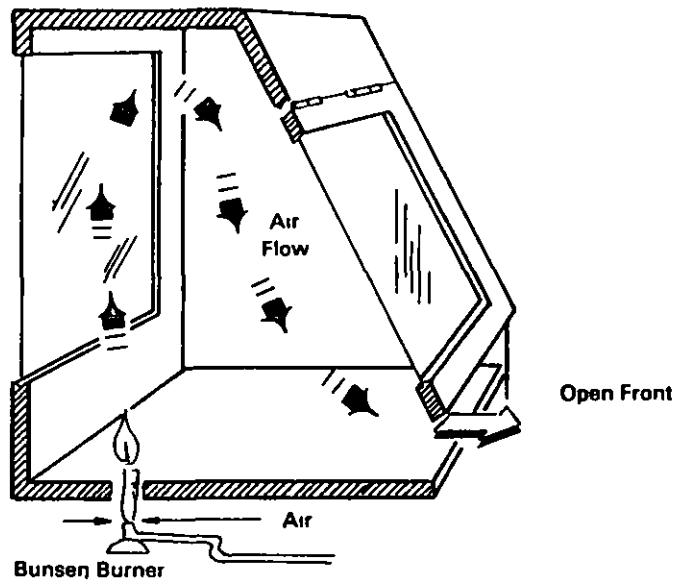

Transverse section of hood

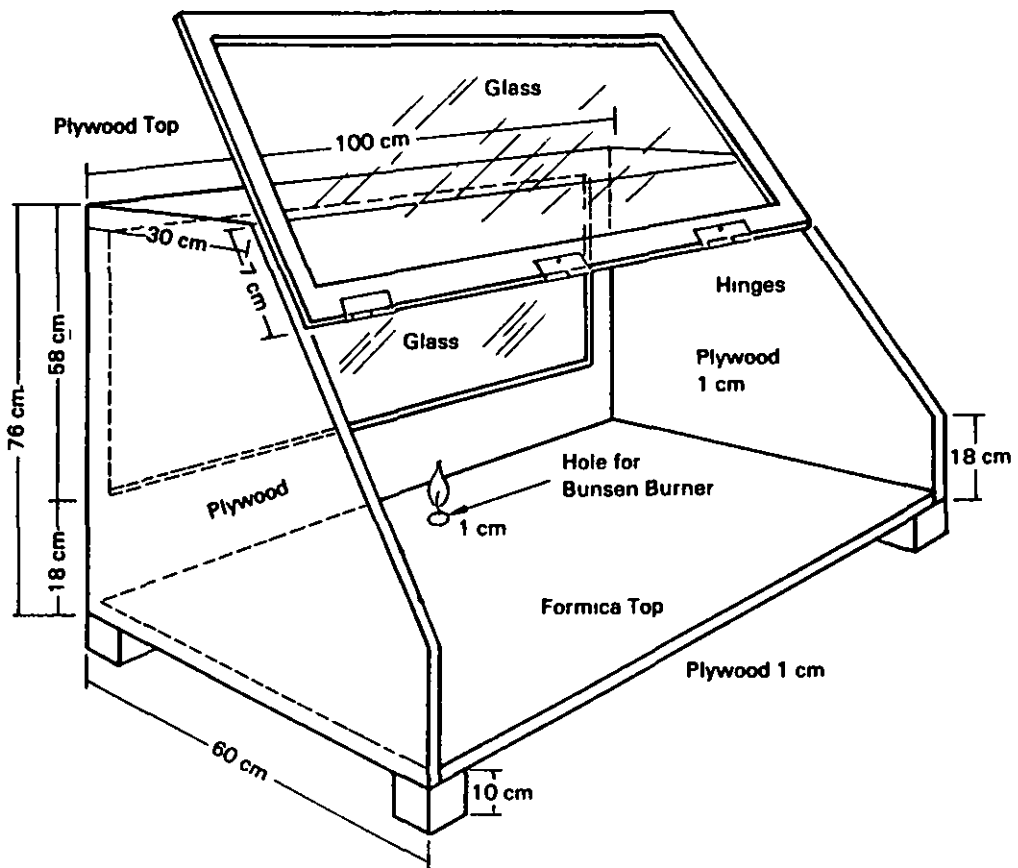

Simple model for a sterile hood

Figure A-1 Simple model for a sterile hood (NifTAL design)

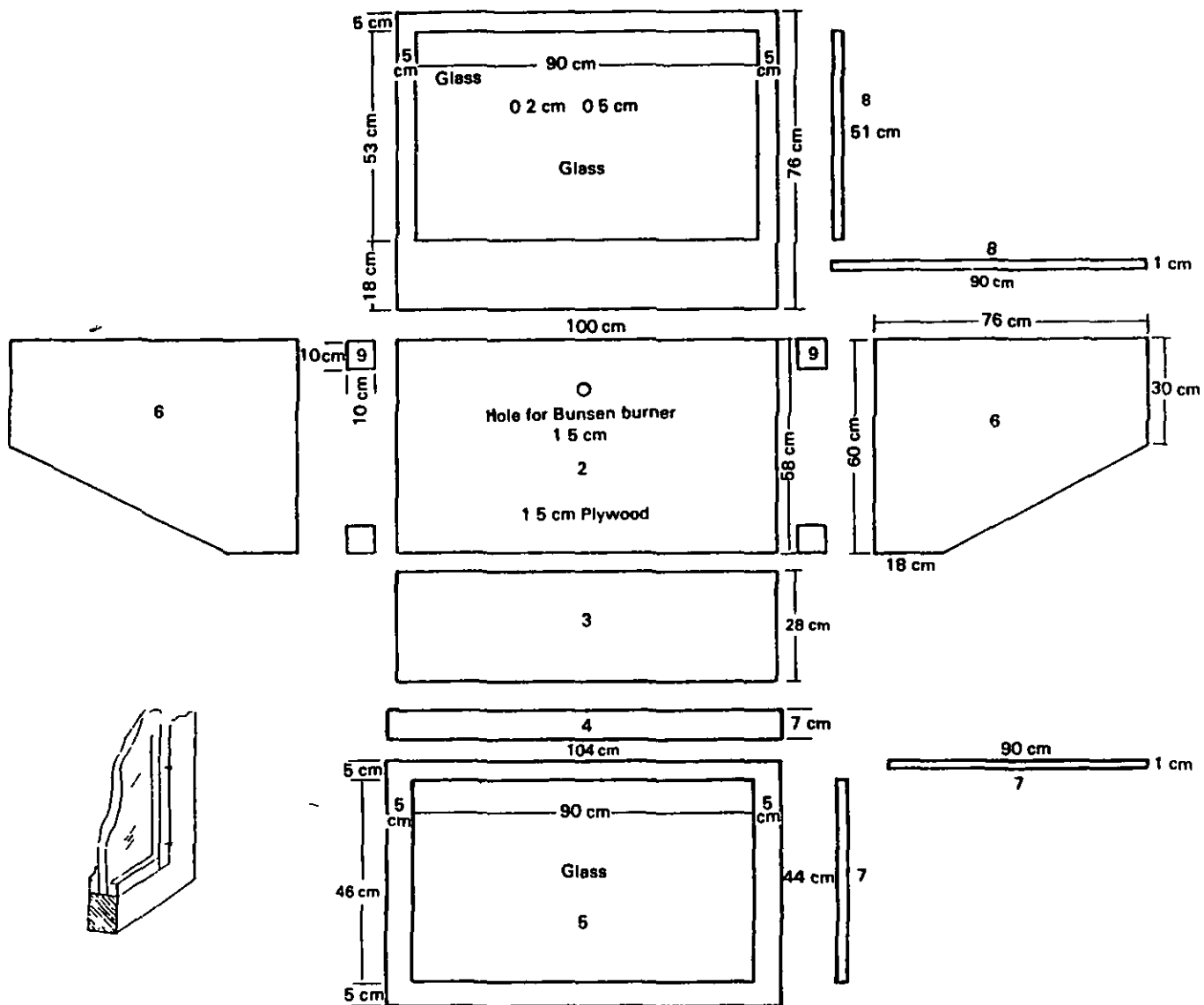

Figure A-2 Plan with specifications for the construction of a sterile hood (NIFTAL design)



# Appendix B

## ACETYLENE REDUCTION METHOD

This method has been used since 1968 for the evaluation of nitrogen fixation by different symbiotic and asymbiotic systems. It is based on the fact that the enzyme nitrogenase reduces not only  $N_2$  but also  $C_2H_2$  (acetylene),  $N_2O$ ,  $CH_3NC$  and other substrates. The reduction of  $C_2H_2$  to  $C_2H_4$  (ethylene) can be measured easily using a gas chromatograph that has a flame ionization detector. Acetylene is a preferred substrate of the enzyme, therefore the reduction of  $N_2$  to  $NH_4$  is inhibited by the presence of acetylene. Theoretically, 3 molecules of  $C_2H_2$  are reduced for each molecule of nitrogen fixed.

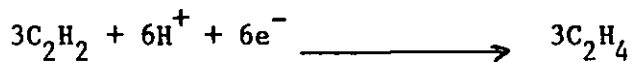
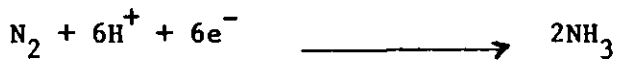

However, this relationship varies considerably, and the method should not be used for quantitative estimations of nitrogen fixation (Minchin et al., 1983). On the other hand, the method can be used for relative estimates of nitrogenase activity at a single point in time, when it is complemented by other observations (nodulation, yield, etc.).

### Procedure

A gas chromatograph with flame ionization detector is used. A 2-m column of Porapak N (80-100 mesh) works well with  $N_2$  as carrier gas (flow rate 30 ml/min) and an oven temperature of 50-100 °C.

1. Acetylene can be produced using calcium carbide ( $CaC_2$ ) (see Figure B-1), or can be taken from a pressurized gas cylinder. Acetylene from a cylinder can be kept in a tire inner tube with an attached rubber tube. Samples are taken from the attached rubber tube thus preventing damage to the inner tube. Some commercial products contain contaminants and it is necessary to purify the gas before use.

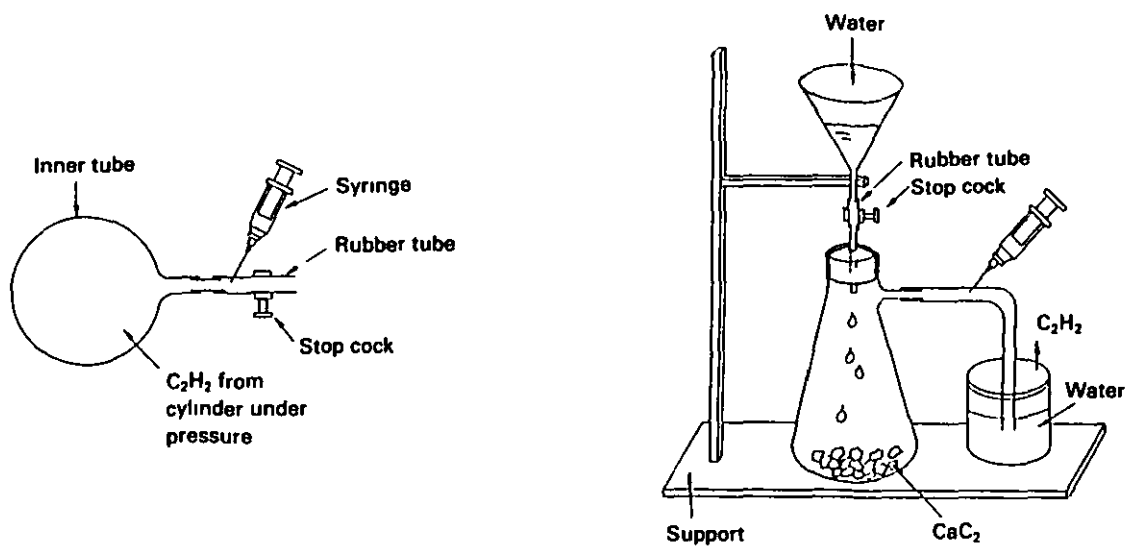

Figure B-1 Two alternative sources of  $C_2H_2$

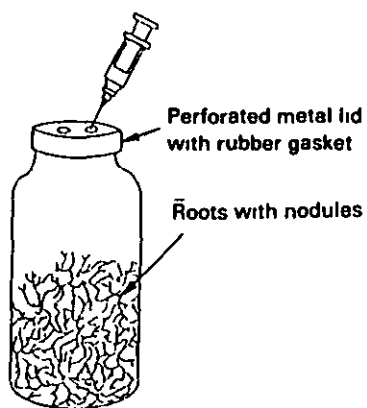

Figure B-2 Incubation of nodulated roots

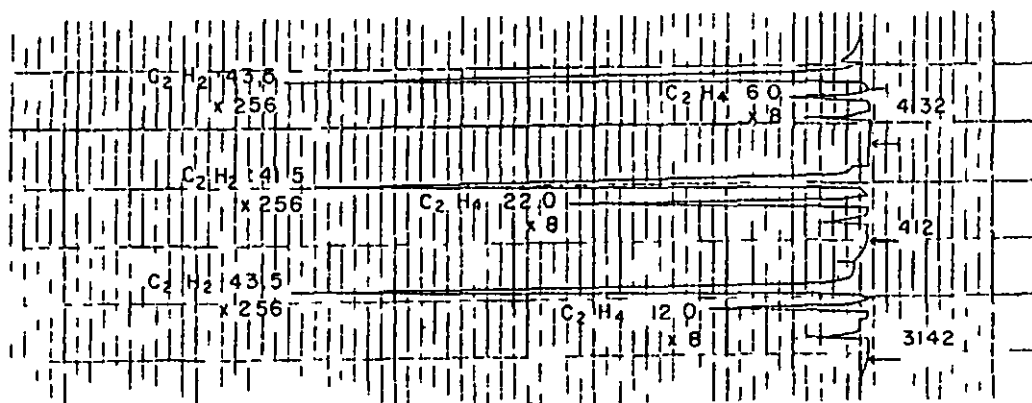

Figure B-3 Peaks of ethylene and acetylene formed by three samples [Ignore first peak formed after injection ( $\leftarrow$ )]

- 2 Turn on the chromatograph and make sure it is working correctly, and there is sufficient gas to complete all of the samples
- 3 Prepare air-tight bottles, of appropriate size, that are fitted with a rubber septum or stopper (serum bottle type) in the cap, that will allow for injecting and removing gas samples Jam or mayonnaise jars with metal caps can be used A rubber liner (cut from a tire inner tube) is put inside the cap and 2-3 perforations made in the metal (see Figure B-2) Grease can be used around the cap to provide a better seal The bottle should be large enough that the roots are not packed tight, but not so large that the  $C_2H_4$  is too diluted
- 4 Harvest plants under cool conditions between 6 and 10 a m to avoid the heat of the day It is advisable in a large experiment to harvest one replication each day
- 5 Put the roots of the harvested plants in the air-tight bottles immediately after harvesting Do not wash the roots as this may inhibit activity, however a damp paper towel can be put in the bottle to maintain freshness Be sure the bottle is tightly sealed to prevent gas leaks
- 6 Using an exact measure, inject acetylene into the prepared bottles to give a final concentration of about 10% For example, in a bottle of 240 ml, inject 25 ml of  $C_2H_2$  into the bottle then mix the gas by pumping the syringe three times, then remove 25 ml of gas from the bottle to equalize the pressure A second option is to remove about 30 ml of air then add 24 ml of acetylene and equalize the pressure by inserting a syringe needle momentarily in the stopper Record the exact time of injection Disposable plastic syringes (50 ml) with fine needles are used
- 7 After 30, 60, and 90 minutes, mix the gas in the flask and remove a sample of 0.5 ml and inject into the chromatograph If the samples

cannot be read immediately, "Vacutainers" (test tubes for blood samples) can be used to store 7 or 10 ml gas samples, for several days. However, it is best to inject the samples into the chromatograph immediately to avoid gas leaks.

8 The height of both gas peaks ( $C_2H_2$  and  $C_2H_4$ ) should be measured. It is necessary to change the attenuation on the chromatograph after reading the  $C_2H_4$  peak in order to be able to read the  $C_2H_2$  peak. For example on the Perkin Elmer chromatograph at CIAT the ethylene peak is usually read at the x8, x16, or x32 attenuation while the acetylene peak is read at x128 or x256 (Figure B-3). If the peak height of  $C_2H_2$  is low in comparison with the other samples, inject another sample to determine if gas has escaped in the injection process or in the incubation bottle. If there was gas escape in the incubation bottle, the values of acetylene reduced are not reliable, and that sample must be considered lost.

9 Calibration of the chromatograph

$$\begin{aligned} 1 \text{ mol of gas (20}^\circ\text{C and 760 mm)} &= 10^6 \mu\text{mol} \\ &= 24 \times 10^3 \text{ ml} \end{aligned}$$

$$1 \text{ ml of gas} = \frac{10^6 \mu\text{mol}}{24 \times 10^3 \text{ ml}} = 41.7 \mu\text{mol}$$

For the calibration, a standard ethylene sample (at 995 ppm) is injected into the chromatograph. The mean peak height for 5 samples of 0.5 ml at an attenuation of x8 is determined.

$$\text{volume of } C_2H_4 \text{ injected} = 0.5 \text{ ml} \times \frac{995}{10^6}$$

$$\begin{aligned} \text{micromoles } C_2H_4 &= 0.5 \text{ ml} \times \frac{995}{10^6} \times 41.7 \mu\text{mol/ml} = \\ &= 20,746 \times 10^{-6} \mu\text{mol } C_2H_4 \end{aligned}$$

If these  $20,746 \times 10^{-6}$   $\mu\text{mol}$  of  $\text{C}_2\text{H}_4$  produce a peak of 10 units on the gas chromatograph (GCU) with an attenuation of x8 the calibration factor (F) is equal to

$$F = 20746 \times 10^{-6} \mu\text{mol C}_2\text{H}_4/\text{GCU at an attenuation x8}$$

Therefore, at an attenuation of x1

$$F = \frac{20746}{8} \times 10^{-6} \mu\text{mol C}_2\text{H}_4/\text{GCU}$$

$$= 2593 \times 10^{-6} \mu\text{mol C}_2\text{H}_4/\text{GCU}$$

It is important to calibrate the chromatograph several times during an assay as the sensitivity may vary during the day

10 To calculate  $\mu\text{mol C}_2\text{H}_4/\text{plant}/\text{hour}$

$$\frac{240}{0.5} \text{ (v)} \times \frac{\text{GCU} \times F}{h \times \text{plants (no)}} = \mu\text{mol C}_2\text{H}_4/\text{plant}/\text{hour}$$

where

v = volume of incubation bottle (ml)

i = volume injected into the chromatograph (ml)

GCU = peak height at attenuation x 1

F = calibration factor  $\mu\text{moles C}_2\text{H}_4/\text{GCU}$

h = hours of incubation

No of plants = no of plants in the bottle

Example  $F = 259 \times 10^{-6}$   $\mu\text{moles}$

Peak 48 GCU at the x8 attenuation = 384 GCU at x1 attenuation

Incubation = 1 h, with two plants/bottle

such that

$$\frac{240}{0.5} \times \frac{384 \times 259 \times 10^{-6}}{1 \times 2} = 23.9 \mu\text{mol}/\text{plant}/\text{hour}$$

# Appendix C

## RECOMMENDED STRAINS

Table C-1 Effective rhizobium strains for tropical forage legumes in Carimagua soil (May 1987)

Genus	Strain CIAT No	Effective on		Origin of the strain	
		Legume species	Ecotype (CIAT No )		
<u>Desmodium</u>	46	<u>D ovalifolium</u>	(350)	SU 462 (Australia)	
	2335	<u>D ovalifolium</u>	(350 3666 3784 3788)	<u>D ovalifolium</u> soil Belem CPATU Brazil	
	2372	<u>D incanum</u>	(13032)	<u>D incanum</u> Carimagua Colombia	
	2434	<u>D ovalifolium</u>	(3776 3788 3794)	<u>Macroptilium</u> <u>atropurpureum</u> with soil from Kudzu km 60 Manaus Brazil	
	2469	<u>D heterophyllum</u> <u>D ovalifolium</u>	(349) (3666, 3784)	<u>D heterophyllum</u> Carimagua Colombia	
	3030	<u>D incanum</u>	(13032)	<u>D incanum</u> Carimagua Colombia	
	3101	<u>D ovalifolium</u>	(3776 3788)	<u>Centrosema plumieri</u> Sierra Nevada Colombia	
	3418	<u>D ovalifolium</u>	(3666 3784 3776 3788 3794 13089)	<u>D ovalifolium</u> Thailand	
			<u>D heterocarpon</u>	(365)	
	4099	<u>D ovalifolium</u>	(13089)	CB 2085 (Australia)	
<u>Centrosema</u>	49	<u>C pubescens</u> <u>C acutifolium</u>	(438) (5112 5277 5568)	CB 1923 (Australia) CI01A	
		<u>C macrocarpum</u>	(5434 5744 5887)		
	590	<u>C pubescens</u>	(5050)	<u>C</u> sp México	
	(ser = 1670)	<u>C macrocarpum</u> <u>C acutifolium</u>	(5065 5744) (5112 5277 5568)	(= TAL 1146)	

(Continued)

Table C-1 (Continued)

Genus	Strain CIAT No	Effective on		Origin of the strain
		Legume species	Ecotype (CIAT No )	
	1670	<u>C pubescens</u> <u>C brasilianum</u> <u>C macrocarpum</u>	(438 5052) (5234) (5065 5744, 5713, 5434 5452)	<u>C pubescens</u> 20 km Cárdenas-Coatzacoal Mexico RAD 87/03
		<u>C acutifolium</u>	(5112, 5568)	
	1780	<u>C pubescens</u> <u>C acutifolium</u> <u>C macrocarpum</u>	(438) (5112 5568) (5065 5434 5713 5737 5744 5887 5452)	<u>C pubescens</u> Pucallpa Peru RAD 179 USM 102
	2290	<u>C acutifolium</u>	(5112 5568)	<u>C sp</u> , Guamal Meta Colombia
	(ser = 1670)	<u>C macrocarpum</u>	(5065 5737 5744)	Meta, Colombia
	2348 (ser = 1670)	<u>C macrocarpum</u>	(5065 5744 5887)	<u>C pubescens</u> 5052 Carimagua
	3101	<u>C macrocarpum</u>	(5065 5062 5713 5744 5887 5434 5452)	<u>C plumieri</u> Sierra Nevada Colombia
		<u>C acutifolium</u>	5568	
	3111	<u>C macrocarpum</u>	(5062, 5744 5713 5452)	<u>C macrocarpum</u> Brazil
	3196	<u>C macrocarpum</u>	(5065, 5062, 5744 5887)	<u>C macrocarpum</u> ERA Paragominas Brazil
	3334	<u>C brasilianum</u>	(5234)	<u>C macrocarpum</u> 5393
	(ser = 1670)	<u>C acutifolium</u> <u>C macrocarpum</u>	(5112) (5065 5744)	(Greenhouse CIAT)
	3694	<u>C acutifolium</u> <u>C macrocarpum</u>	(5112 5568) (5744 5877 5713 5452)	<u>C bifidum</u> 15087 S Rita Vichada Colombia

(Continued)

Table C-1 (Continued)

Genus	Strain CIAT No	Effective on		Origin of the strain
		Legume species	Ecotype (CIAT No )	
<u>Stylosanthes</u>	71	<u>S</u> <u>guianensis</u>		<u>Stylosanthes</u> sp Huila Colombia (= TAL 658)
	870	<u>S</u> <u>capitata</u>	10280	CB 2898 Australia
	995	<u>S</u> <u>capitata</u>	10280	<u>S</u> <u>capitata</u> Venezuela RAD 446/01
	2138	<u>S</u> <u>capitata</u>	10280	<u>S</u> <u>capitata</u> , Nopolis Goias Brazil RAD 330/14
<u>Pueraria</u>	643	<u>P</u> <u>phaseoloides</u>	9900	<u>P</u> <u>phaseoloides</u> Chinchiná Colombia
	2434	<u>P</u> <u>phaseoloides</u>	9900 4600	<u>Macroptilium</u> <u>atropurpureum</u> with soil from kudzu km 60 Manaus Brazil
	3287	<u>P</u> <u>phaseoloides</u>	9900	<u>P</u> <u>phaseoloides</u> Introducciones II Carimagua Colombia
	3648 3649	<u>P</u> <u>phaseoloides</u>	9900	<u>P</u> <u>phaseoloides</u> El Refugio Villavicencio Colombia
	3796	<u>P</u> <u>phaseoloides</u>	9900	<u>P</u> <u>phaseoloides</u> Itabela Brazil
	3850	<u>P</u> <u>phaseoloides</u>	9900	<u>P</u> <u>phaseoloides</u> Thailand
	3918	<u>P</u> <u>phaseoloides</u>	9900	TAL 647 UMKL 56
<u>Arachis</u>	2138	<u>A</u> <u>pinto</u>	17434	<u>S</u> <u>capitata</u> Nopolis Goias Brazil RAD 330/14
	2335	<u>A</u> <u>pinto</u>	17434	<u>D</u> <u>ovalifolium</u> soil from Belem, CPATU Brazil

(Continued)



Table C-1 (Continued)

Genus	Strain CIAT No	Effective on		Origin of the strain
		Legume species	Ecotype (CIAT No )	
	3101	<u>A pinto</u>	17434	<u>C plumieri</u> Sierra Nevada, Colombia
	3144	<u>A pinto</u>	17434	<u>A pinto</u> , Carimagua Pista Colombia
	3806	<u>A pinto</u>	17434	<u>A pinto</u> , Guayabal Meta Colombia
	3810	<u>A pinto</u>	17434	<u>A pinto</u> air strip Carimagua, Colombia
<u>Calopogonium</u>	453	<u>C mucunoides</u>		<u>C mucunoides</u> Granada
	454			Meta Colombia
	3115	<u>C mucunoides</u>		<u>C caeruleum</u> Quilichao Colombia
<u>Flemmingia</u>	4203	<u>F macrophylla</u>	17403	<u>F macrophylla</u>
	4215			Quilichao Colombia

Table C-2 Strains effective in Phaseolus vulgaris trials (May, 1987)

Environmental conditions	CIAT number	Origin
<b>Acid soils</b>		
	899	(M-188) Carmen de Viboral, Colombia
	144	(Z-119) Antioquia, Colombia
	639	(Z-644) La Buitrera, Colombia
	876	El Guarne, Colombia
	652	(Z-629) Palmira, Colombia
<b>Warm climate</b>		
	45	(F-310) Brazil
	166	(Z-151) Buga, Colombia
	348	(Z-305) Palmira, Colombia
	640	(Z-640) La Buitrera, Colombia
	899	(M-188) Carmen de Viboral, Colombia
<b>Cool climate</b>		
	5	(G-327) El Chuzo Caldas, Colombia
	323	(95-R10) Canada
	613	(Z-621) Chinchiná, Colombia
	7001	(IpiHy-10) Ipiiales, Colombia
	7002	(IpiHy-14) Ipiiales, Colombia
<b>General</b>		
	144	(Z-119) Antioquia, Colombia
	632	(# 21) Guatemala
	652	(Z 629) Palmira, Colombia
	899	(M-188) Carmen de Viboral, Colombia

Table C-3 Rhizobium strains recommended for inoculation of forage legumes in well-drained Isohyperthermic savanna (1987)

Legume species	Ecotype (CIAT no )	Recommended strain
<u>Arachis pinto</u>	17434	3101
<u>Centrosema brasilianum</u>	5234	3101
<u>Centrosema macrocarpum</u>	5065	3101
<u>Centrosema macrocarpum</u>	5744	3101
<u>Centrosema macrocarpum</u>	5887	3101
<u>Centrosema sp</u>	5112	3101
<u>Centrosema sp</u>	5277	3101
<u>Centrosema sp</u>	5568	3101
<u>Desmodium heterocarpon</u>	3787	3418
<u>Pueraria phaseoloides</u>	9900	2434
<u>Stylosanthes capitata</u>	1019	870 + 995 + 2138
<u>Stylosanthes capitata</u>	1441	870 + 995 + 2138
<u>Stylosanthes capitata</u>	2044	870 + 995 + 2138
<u>Stylosanthes capitata</u>	10280	870 + 995 + 2138
<u>Stylosanthes guianensis (tardío)</u>	2031	71 <sup>a</sup>
<u>Stylosanthes guianensis (tardío)</u>	2362	71 <sup>a</sup>
<u>Stylosanthes guianensis (tardío)</u>	10136	71 <sup>a</sup>
<u>Stylosanthes macrocephala</u>	1643	n d <sup>a</sup>
<u>Stylosanthes macrocephala</u>	2133	n d <sup>a</sup>
<u>Stylosanthes macrocephala</u>	2286	n d <sup>a</sup>
<u>Stylosanthes macrocephala</u>	2756	n d <sup>a</sup>
<u>Zornia glabra</u>	7847	71 <sup>a</sup>

a In the Eastern Plains of Colombia these legumes do not need inoculating n d = not determined

Table C-4 Rhizobium strains recommended for inoculation of forage legumes in tropical rainforests (1987)

Legume species	Ecotype (CIAT no )	Recommended strain
<u>Centrosema brasilianum</u>	5234	3101
<u>Centrosema macrocarpum</u>	5065	3101
<u>Centrosema macrocarpum</u>	5713	3101
<u>Centrosema macrocarpum</u>	5744	3101
<u>Centrosema pubescens</u>	438	1670
<u>Centrosema pubescens</u>	442	1670
<u>Centrosema pubescens</u>	5189	1670
<u>Centrosema</u> sp	5112	3101
<u>Centrosema</u> sp	5277	3101
<u>Centrosema</u> sp	5568	3101
<u>Desmodium heterophyllum</u>	349	3418
<u>Desmodium heterophyllum</u>	3782	3418
<u>Desmodium ovalifolium</u>	350	3418
<u>Leucaena leucocephala</u>		1967
<u>Pueraria phaseoloides</u>	9900	2434
<u>Stylosanthes capitata</u>	10280	870 + 995 + 2138
<u>Stylosanthes guianensis</u>	64	71
<u>Stylosanthes guianensis</u>	136	71
<u>Stylosanthes guianensis</u>	184	71
<u>Stylosanthes guianensis</u> (tardío)	1280	71
<u>Stylosanthes guianensis</u> (tardío)	10136	71
<u>Zornia glabra</u>	7847	71
<u>Zornia glabra</u>	8283	71
<u>Zornia latifolia</u>	728	71

Table C-5 Strains recommended for tropical forage legumes by other institutions <sup>a</sup>

CIAT Strain No	Effective for	Synonyms (other lab numbers)
904	<u>P vulgaris</u>	Semia 487
903	<u>P vulgaris</u>	TAL 182
-	<u>P vulgaris</u>	TAL 1376
7004	<u>P vulgaris</u>	DF V23
7003	<u>P vulgaris</u>	CO5
4477	<u>Calopogonium muconoides</u>	Semia 6152, BR1602
4461, 4481	{ <u>Crotalaria, Canavalia,</u>	CPAC F2 (1J), Semia 6156
4462, 4483		
4102	Various legumes	CB 756
4471	<u>D incanum</u>	Semia 6028, TAL 569
109	<u>D intortum</u>	CB 627
4465	<u>Neonotonia wightii</u>	Semia 656
3872	<u>P phaseoloides</u>	DFQ1
3894	<u>C pubescens</u>	UMKL 44, TAL 651
3895	<u>C pubescens</u>	UMKL 09, TAL 655
4473	<u>Centrosema spp</u>	Semia 6146, BRI808, C106
4463, 4479	<u>Stylosanthes spp</u>	Semia 6154 (BR 446)
4464, 4480	<u>Stylosanthes spp</u>	Semia 6155 (BR 502)
4103	<u>Stylosanthes spp</u>	TAL 1023 (CB82)
860	<u>Stylosanthes spp</u>	CB 1650
4100	<u>Stylosanthes spp</u>	CB 2227
4471	<u>D incanum</u>	Semia 6028, TAL 569
109	<u>D intortum</u>	CB 627
2329	<u>Leucaena spp</u>	Semia 6070, DF 15
2328	<u>Leucaena spp</u>	Semia 6069, DF 10
4478	<u>Leucaena spp</u>	Semia 6153, BR 827
1961	<u>Leucaena spp</u>	TAL 82
1967	<u>Leucaena spp</u>	TAL 1145, ST 71
3556, 843	<u>Leucaena spp</u>	CB 81, TAL 582
42	<u>Leucaena spp</u>	NGR 8

<sup>a</sup> Strains from other institutes which have been effective at CIAT are included in Tables C-1 and C-2. We request that relevant information on strain recommendations that are not included in this list be sent to CIAT, and if possible, the strains as well.



- FONAIAP (Fondo Nacional de Investigaciones Agropecuarias) 1982  
 Aspectos biológicos agronómicos y tecnológicos de la rizobiología  
 L B Ayala (ed ) Serie Especial, no 2-02 Maracay, Venezuela 78 p
- IAEA (International Atomic Energy Agency) 1983 A guide to the use of  
 nitrogen-15 and radioisotopes in studies of plant nutrition  
 calculations and interpretation of data IAEA TECDOC-288 Vienna,  
 Austria
- Jones, J B and Steyn, W J A 1973 Sampling, handling and analyzing  
 plant tissue samples In Walsh, L M and Beaton, J D (eds ) Soil  
 testing and plant analysis Soil Sci Soc Amer , Madison, WI  
 p 249-270
- Jordan, D C 1984 In Krieg, N R and Holl, J G (eds ) Bergey's  
 manual of systematic bacteriology, vol 1 Williams & Wilkins,  
 Baltimore, USA 234-254
- Keeney D R and Nelson D W 1982 Nitrogen inorganic forms In Page,  
 A L , Miller, R H and Keeney, D L 1982 Methods of soil  
 analysis Part 2 chemical and microbiological properties American  
 Society of Agronomy, Madison, Wisconsin, USA 643 p
- Kerridge, P C , Cook, B G and Everett, M L 1973 Application of  
 molybdenum trioxide in the seed pellet for sub-tropical pasture  
 legumes Trop Grassl 7 229-232
- Keyser, H M 1978 Ph D diss Univ of California, Davis, CA, USA
- Keyser, H H and Munns, D N 1979 Tolerance of rhizobia to acidity,  
 aluminium and phosphate Soil Sci Soc Amer J 43 519-523
- Leonard, L T 1943 A simple assembly for use in the testing of  
 cultures of rhizobia J Bact 45 523-525

- Maier, R J , Campbell, N E R , Hanus, F J , Simpson, F B , Russel, S A and Evans, H J 1978 Expression of hydrogenase activity in free-living Rhizobium japonicum Proc Nat Acad Sci USA 75 3258-3262
- Minchin, F R , Witty, J F , Sheehy J E and Muller, M 1983 A major error in the acetylene reduction assay decreases in nodular nitrogenase activity under assay conditions J Exp Bot 34 641-649
- Norris, D O and Date, R A 1976 Legume bacteriology In Tropical pasture research principles and methods C A B Bull 51, Comm Bureau of Pastures and Field Crops p 134-174
- Roughley, R J 1970 The preparation and use of legume seed inoculants Plant Soil, 32 675-701
- Salinas, J G and García, R 1985 Métodos químicos para el análisis de suelos ácidos y plantas forrajeras Programa de Pastos Tropicales, CIAT, Cali, Colombia 83 p
- \_\_\_\_\_ and Goedert, W J 1987 Ensayos de ajuste de fertilización para establecer pasturas tropicales In Investigaciones de apoyo para la evaluación de pasturas, Red Internacional de Evaluación de Pastos Tropicales Tercera Reunión del Comité Asesor de la RIEPT, October 1985 Proceedings Centro Internacional de Agricultura Tropical Cali, Colombia p 15-27
- Sandman W P L 1970 Practical aspects of Rhizobium bacteriology Rhodesian Ministry of Agriculture 185 p
- Seiffert, M F and Miranda, C M B 1983 Recomendações para inoculação e peletização de sementes de leguminosas forrageiras tropicais CNPGC Campo Grande, Brasil Comunicado Técnico No 17



## References

- Allen, S E , Terman, G L , and Clements, L B 1976 Greenhouse techniques for soil-plant fertilizer research National Fertilizer Development Center, Tennessee Valley Authority, Bulletin No Y-104 57 p
- American Society of Agronomy 1982 Methods of soil analysis Part 2 chemical and microbiological properties Madison, WI, USA
- Bergersen, F J 1980 Methods for evaluating biological nitrogen fixation John Wiley, NY 702 p
- Brockwell, J 1982 Inoculation methods for field experiments and farmers In Vincent, J M (ed ) Nitrogen fixation in legumes Academic Press p 211-227
- \_\_\_\_\_, Diatloff A , Roughley, R J , and Date, R A 1982 Selection of rhizobia for inoculants In Vincent, J M (ed ) Nitrogen fixation in legumes Academic Press p 173-191
- Burton, J C 1976 Methods of inoculating seeds and their effect on survival of rhizobia In Nutman, P S (ed ) Symbiotic nitrogen fixation in plants, Cambridge University Press p 175-189
- Cataldo, D A , Haroon, M, Schrader, L E and Youngs, V L 1975 Rapid colorimetric determination of nitrate in plant tissue by nitration of salicylic acid Commun Soil Sci and Plant Anal 6 71-80
- CIAT (Centro Internacional de Agricultura Tropical) 1981 Informe Anual del Programa de Pastos Tropicales 1980 Cali, Colombia p 57-68
- \_\_\_\_\_, 1985 Informe Anual del Programa de Pastos Tropicales 1984 Cali, Colombia p 156-159

- \_\_\_\_\_ 1982a Manual para la evaluación agronómica Red  
Internacional de Evaluación de Pastos Tropicales Toledo, J M  
(ed ) Cali, Colombia 168 p
- \_\_\_\_\_ 1979-1985 Informe Anual del Programa de Frijol [1978 through  
1984] Cali, Colombia
- \_\_\_\_\_ 1982-1984 Informe Anual del Programa de Pastos  
Tropicales [1981 through 1983] Cali, Colombia
- \_\_\_\_\_ 1987 Standard system for the evaluation of bean germplasm  
van Schoonhoven, A and Pastor-Corrales, M A (compilers) Cali,  
Colombia 54 p
- Cochrane, T T , Salinas, J G and Sánchez, P A 1980 An equation  
for liming acid mineral soils to compensate crop aluminium tolerance  
Trop Agric 57 133-140
- Chapman, H D and Pratt, P F 1961 Methods of analysis for soils,  
plants and waters Division of Ag Sci , Univ of California,  
Riverside, CA 309 p
- Daniel, R M , Limmer, R W , Steele, K W and Smith, I M 1982  
Anaerobic growth nitrate reduction and denitrification in 46  
Rhizobium strains J Gen Microbiol 128 1811-1815
- de Faria, S M , de Polli, H, and Franco, A A 1985 Adesivos para  
inoculação e revestimento de sementes de leguminosas Pesq  
Agropec Bras (Brasília) 20 169-176
- FAO (Food and Agricultural Organization) 1985 Manual técnico sobre la  
fijación simbiótica de nitrógeno leguminosa-rizobio FAO Rome,  
Italy

- Sinclair, M J and Eaglesham, A R J 1984 Intrinsic antibiotic resistance in relation to colony morphology in three populations of West African cowpea rhizobia Soil Biol Biochem 16 247-251
- Somasegaran, P and Hoben J H 1985 Methods in legume-Rhizobium technology NifTAL Project and MIRCEN, Paia, Hawaii 367 p
- Steyn W , J A 1959 Leaf analysis, errors involved in the preparative phase J Agr Food Chem 7 344-348
- Sylvester-Bradley, R , Ayarza, M A , Méndez, J E and Moriones, R 1983 Use of undisturbed soil cores for evaluation of Rhizobium strains and methods for inoculation of tropical forage legumes in a Colombian Oxisol Plant Soil 74 237-247
- \_\_\_\_\_ and Mosquera, D 1985 Nitrification and responses to Rhizobium inoculation in a tropical savanna as affected by land preparation In Kang, B T and Van der Heide, J (eds ) Nitrogen management in farming systems in humid and subhumid tropics Institute for Soil Fertility (IB), Haren, The Netherlands
- Vincent, J M 1970 A manual for the practical study of root-nodule bacteria Blackwell Scientific Publications, Oxford and Fdinburgh 164 p
- Zablotwicz, R M , Eskew, D L and Focht, D D 1978 Denitrification in Rhizobium Can J Microbiol 24 757-760



A CIAT Publication  
The Tropical Pastures Program,  
the Bean Program and  
the Training and Communications Program,  
Publication Unit

Technical editors    Rosemary Sylvester-Bradley  
                                 and Judy Kipe-Nolt

Production editor    Norbert Molzan

Printing                Graphic Arts Unit, CIAT



MANUAL UPDATE

If you wish to receive updated pages or complete sections of this manual, please fill in the cut-away form below and send it to the address indicated

Your name will be automatically entered in the manual update list



Oficina de Distribución y Mercadeo  
Unidad de Publicación  
CIAT  
Apartado 6713  
Calí, Colombia

Please include my name and address in the mailing list to receive updates of Legume-Rhizobium Symbiosis Methods Manual for Evaluation, Selection and Agronomic Management

Name \_\_\_\_\_

Position \_\_\_\_\_

Institution \_\_\_\_\_

Address \_\_\_\_\_

City \_\_\_\_\_ Country \_\_\_\_\_

**From**

**Oficina de Distribución y Mercadeo  
Unidad de Publicación  
CIAT  
Apartado 6713  
Cali, Colombia**